

TIP & ROLL ALUMINUM BLEACHER 2 ROW WITH SINGLE FOOT PLANK FOR  
7'-6", 9', 12', 15', 21', AND 27' LENGTH

| GENERAL SPECIFICATIONS |                 |                  |              | METRIC SPECIFICATIONS |              |
|------------------------|-----------------|------------------|--------------|-----------------------|--------------|
| PART NUMBER            | BLEACHER LENGTH | SEATING CAPACITY | WEIGHT (Lbs) | BLEACHER LENGTH       | WEIGHT (Lbs) |
| TRB0208                | 7'-6"           | 10               | 71           | 2286 mm               | 32 kg        |
| TRB0209                | 9'-0"           | 12               | 81           | 2743 mm               | 37 kg        |
| TRB0212                | 12'-0"          | 16               | 112          | 3658 mm               | 51 kg        |
| TRB0215                | 15'-0"          | 20               | 131          | 4572 mm               | 60 kg        |
| TRB0221                | 21'-0"          | 28               | 182          | 6401 mm               | 83 kg        |
| TRB0227                | 27'-0"          | 36               | 233          | 8230 mm               | 106 kg       |

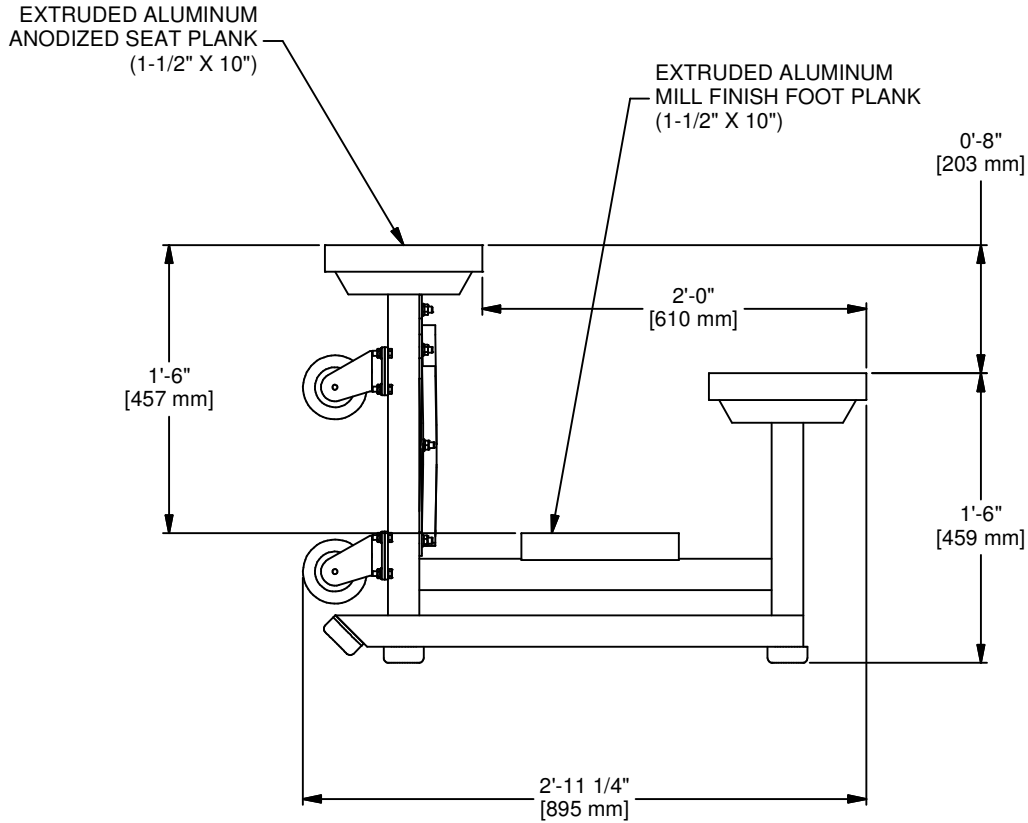

TOP VIEW



|     |     |          |
|-----|-----|----------|
| B   | JJC | 04/03/15 |
| A   | JJC | 06/12/14 |
| REV | BY  | DATE     |



Gared Holdings, LLC  
9200 E. 146th St. Noblesville, IN 46060

THIS DOCUMENT CONTAINS TRADE SECRET AND OTHER MATERIALS WHICH ARE PROTECTED BY CONFIDENTIALITY NOTICE AND AGREEMENT AND BY COPYRIGHT. ANY USE OR COPYING OF THIS DOCUMENT EXCEPT AS AUTHORIZED BY GARED HOLDINGS, LLC IS STRICTLY PROHIBITED.

TIP & ROLL BLEACHER 2 ROW

|   |                    |                           |
|---|--------------------|---------------------------|
| DRAWN<br>CONNERLEY                              | DATE<br>11/13/2013 | DATE ISSUED<br>11/13/2013 |
| APPROVED<br>CONNERLEY                           | DATE<br>11/13/2013 |                           |
| FILE LOC. Q:\Inventor Files\Specification Files |                    |                           |
| SIZE<br>A                                       | SCALE              | SHT. NO.<br>1 OF 2        |
| PART NO.<br>TRB02XX                             |                    | REV<br>B                  |

## Bleacher Specifications: 2 row Spectator <sup>tm</sup> Series

### TRB MODEL –Tip-N-Roll

#### SECTION 13125

##### Part 1- General Requirements

- 1.1 Description
  - A. Design and Build of Angle Frame Bleachers
- 1.2 Quality Assurance
  - A. Manufacturer: Gared Holdings, LLC , 9200 E. 146<sup>th</sup> St., Noblesville, In 46060
  - B. Qualifications: Manufacturer shall have a minimum of ten years of experience in the design and manufacture of angle frame bleachers
  - C. Welders and Procedures to be AWS certified
  - D. Codes and standards: International Building Code & ICC 300-2012
- 1.3 Warranty
  - A. Warranty shall include defects in materials and workmanship under normal use and does not apply to work that has been damaged by abuse or natural disaster. Warranty period shall be for a period of 1 Year and begin on date material is received by owner or subcontractors date of completion

##### Part 2- Products

- 2.1 Design
  - A. Design loads to be in accordance with International Building Code (IBC) & ICC 300-2012 edition
    - 1) Live Load- Structure uniform 100 psf, Seat and Foot Plank- 120 plf
    - 2) Sway Load- Perpendicular to seats – 10 plf, Parallel to seats – 24 plf
  - B. Design loads to be in accordance with International Building Code (IBC) & ICC 300-2012 (Section 303, Structural Design)
  - C. Frames: Welded aluminum angle (2" x 2" x 3/16") spaced at 6'0" (max) intervals and joined by aluminum angle braces
  - D. Seats: (1) nominal 2" x 10" anodized aluminum
  - E. Treads: (1) nominal 2" x 10" mill finish aluminum on all rows
  - F. Rise/Run dimensions: 8" vertical rise/ 24" horizontal run per row, **Row 1 seat height 18 " above grade**
- 2.2 Materials and Finishes
  - A. Frames: Aluminum angle 6061-T6 or mechanical equivalent
  - B. Braces: Aluminum Angle 6061-T6 or mechanical equivalent
  - C. Seats: Aluminum alloy 6063-T6 clear anodized 204R1, AA-M10C22A31 , wall thickness of .078
  - D. Treads: Aluminum alloy 6063-T6 mill finish, wall thickness of .078
  - E. Casters: 4" Non-Marring swivel
  - F. Foot pads: Non-Marring white rubber
  - G. Hardware: Nuts and bolts to be zinc plated
  - H. Accessories: End caps, anodized aluminum 6063-T6 anodized, Mounting clips & splices to be mill aluminum 6061-T6

##### Part 3- Execution

- 3.1 Installation
  - A. Install product in accordance with manufacturer installation instructions and drawings
  - B. Design is based on Manufacturer's interpretation of International Building Code, local codes may vary and result in additional requirements , It is the owner's responsibility to verify local code compliance
  - C. Owner shall be responsible to verify site location and provide level foundation or ground that is adequate to support bleacher loads, no provisions have been included (unless noted) for anchoring of bleacher to prevent wind overturning