

DETAIL C
SCALE 1/10

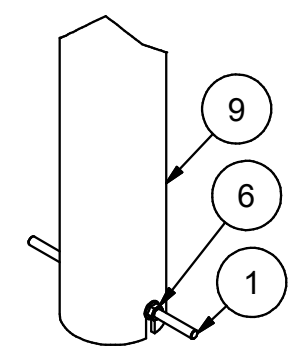

DETAIL D
SCALE 1/10

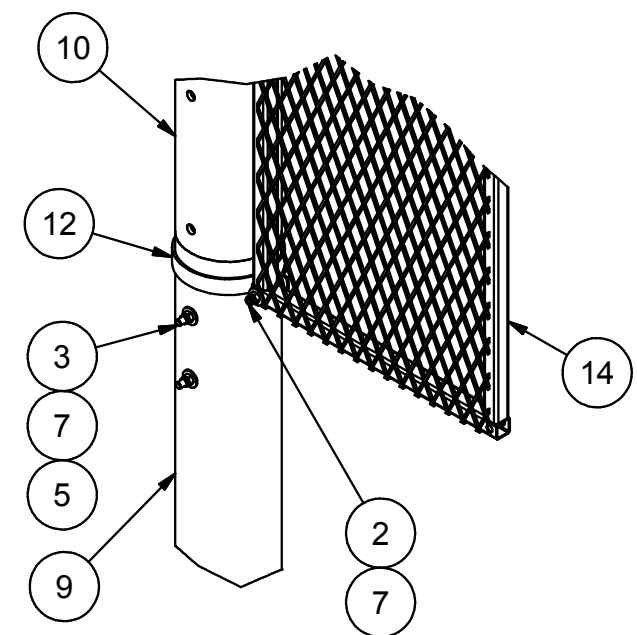

DETAIL A
SCALE 1/10

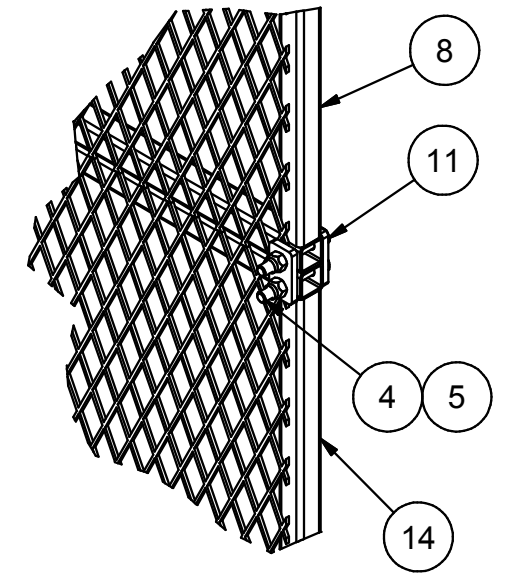

DETAIL B
SCALE 1/6

PARTS LIST

ITEM	QTY	PART NUMBER	DESCRIPTION
1	2	101151787	1/2"-13 X 12" THREADED ROD
2	24	501-6-16-40	BOLT, CARRIAGE 3/8-16 UNC X 2.5
3	8	502-6-16-104	HEX BOLT, 3/8-16 UNC X 6.5
4	20	502-6-16-40	HEX BOLT, 3/8-16 UNC X 2.5
5	52	545-6-16Z	HEX NUT, NYLON LOCK 3/8-16
6	4	548-8-13	HEX NUT, SERRATED FLANGE 1/2-13
7	32	561-6G	FLAT WASHER 3/8 GALV
8	8	955801003	WING WELDMENT, 4' X 18", FOUL POLE
9	2	955801012	BASE POLE, 30'
10	4	955801016	POLE WELDMENT, 30' WING
11	20	955801018	WING CONNECTION PLATE
12	24	955801019	POST CLASP, 5.56" DIA. POST
13	2	955801021	5 9/16 FLAT POST CAP GALV.
14	4	955801022	WING WELDMENT, 3' X 18", FOUL POLE

NOTE: QTYS SHOWN ARE FOR ONE PAIR OF FOUL POLES

FINISHED WEIGHT 1290.425 lbmass

UNLESS OTHERWISE SPECIFIED
DIMENSIONS ARE IN INCHES
[XX.XX] DIMENSIONS ARE IN MM
TOLERANCES ARE:
.X ± 0.060 [1.50 mm]
.XX ± 0.030 [0.75 mm]
.XXX ± 0.010 [0.25 mm]
ANGLES
X. = 1°
X.X = 1/2°

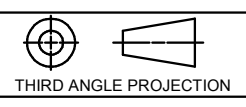

PSS
PERFORMANCE
SPORTS SYSTEMS

G
GARED

Gared Holdings, LLC
9200 E. 146th St. Noblesville, IN 46060

THIS DOCUMENT CONTAINS TRADE SECRET AND OTHER MATERIALS WHICH ARE PROTECTED BY CONFIDENTIALITY NOTICE AND AGREEMENT AND BY COPYRIGHT. ANY USE OR COPYING OF THIS DOCUMENT EXCEPT AS AUTHORIZED BY GARED HOLDINGS, LLC IS STRICTLY PROHIBITED.

PERM. 30' FOUL POLE (PAIR)

DRAWN	PERRY	DATE	12/9/2013	MATERIAL
APPROVED		DATE		FINISH
FILE LOC.	Q:\Inventor Files\950,000,000			DWG. NO.
SIZE	SCALE	SHT. NO.	PART NO.	REV
B		1 OF 1	BSPOLE-30P	A

REV	BY	DATE	ECN	REVISION DESCRIPTION
A	WDC	09-13-15		ADDED THREADED ROD 101151787 AND NUTS 548-8-13