

SECTION A-A

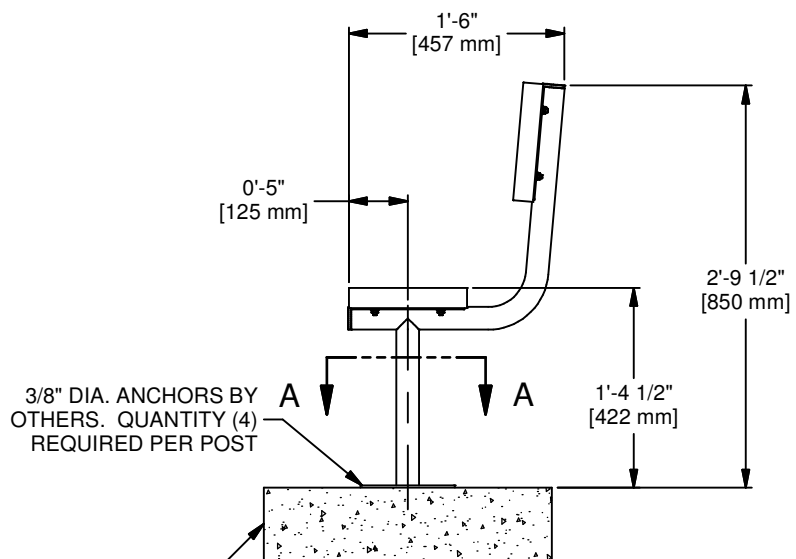

CONCRETE BASE BY OTHERS

SEATS ARE CONSTRUCTED OF 10" [254 mm] WIDE ANODIZED ALUMINUM. FRAMEWORK IS COMPRISED OF WELDED HEAVY GAUGE STEEL TUBING FOR SUPERIOR SUPPORT AND STRENGTH. END CAPS ARE CONSTRUCTED OF DIE CUT ALUMINUM STRIPS WITH PUNCHED HOLES FOR SCREWS OR RIVETS.

REV	BY	DATE



Gared Holdings, LLC
9200 E. 146th St. Noblesville, IN 46060

THIS DOCUMENT CONTAINS TRADE SECRET AND OTHER MATERIALS WHICH ARE PROTECTED BY CONFIDENTIALITY NOTICE AND AGREEMENT AND BY COPYRIGHT. ANY USE OR COPYING OF THIS DOCUMENT EXCEPT AS AUTHORIZED BY GARED HOLDINGS, LLC IS STRICTLY PROHIBITED.

21' SURFACE MOUNT BENCH WITH BACK

DRAWN	CONNERLEY	DATE	8/14/2014	DATE ISSUED	8/14/2014
APPROVED		DATE			

FILE LOC. Q:\Inventor Files\Specification Files\

SIZE	SCALE	SHT. NO.	PART NO.	REV
A		1 OF 2	BE21SMWB	

Bench Specifications: Spectator tm Series

"SMWB" Surface Mount with Back Model

SECTION 13125

Part 1- General Requirements

- 1.1 Description
 - A. Design and Build of Aluminum and Steel Benches
- 1.2 Quality Assurance
 - A. Manufacturer: Gared Holdings, LLC , 9200 E. 146th St., Noblesville, In 46060
 - B. Qualifications: Manufacturer shall have a minimum of ten years of experience in the design and manufacture of benches
 - C. Welders and Procedures to be AWS certified
- 1.3 Warranty
 - A. Warranty shall include defects in materials and workmanship under normal use and does not apply to work that has been damaged by abuse or natural disaster. Warranty period shall be for a period of 1 Year and begin on date material is received by owner or subcontractors date of completion

Part 2- Products

- 2.1 Design
 - A. Frames: Welded steel tubing spaced at 6'0" (max) intervals
 - B. Seats: (1) nominal 2" x 10" anodized aluminum
 - C. Backrest: (1) nominal 2" x 10" anodized aluminum
- 2.2 Materials and Finishes
 - A. Frames: Heavy Gauge Steel Tubing with hot dipped galvanized finish, ASTM A-123
 - B. Seats: Aluminum alloy 6063-T6 clear anodized 204R1, AA-M10C22A31 , wall thickness of .078
 - C. Backrest: Aluminum alloy 6063-T6 clear anodized 204R1, AA-M10C22A31 , wall thickness of .078
 - D. Hardware: Nuts and bolts to be galvanized
 - E. Accessories: End caps, anodized aluminum 6063-T6 anodized, Mounting clips & splices to be mill aluminum 6061-T6

Part 3- Execution

- 3.1 Installation
 - A. Install product in accordance with manufacturer installation instructions and drawings