

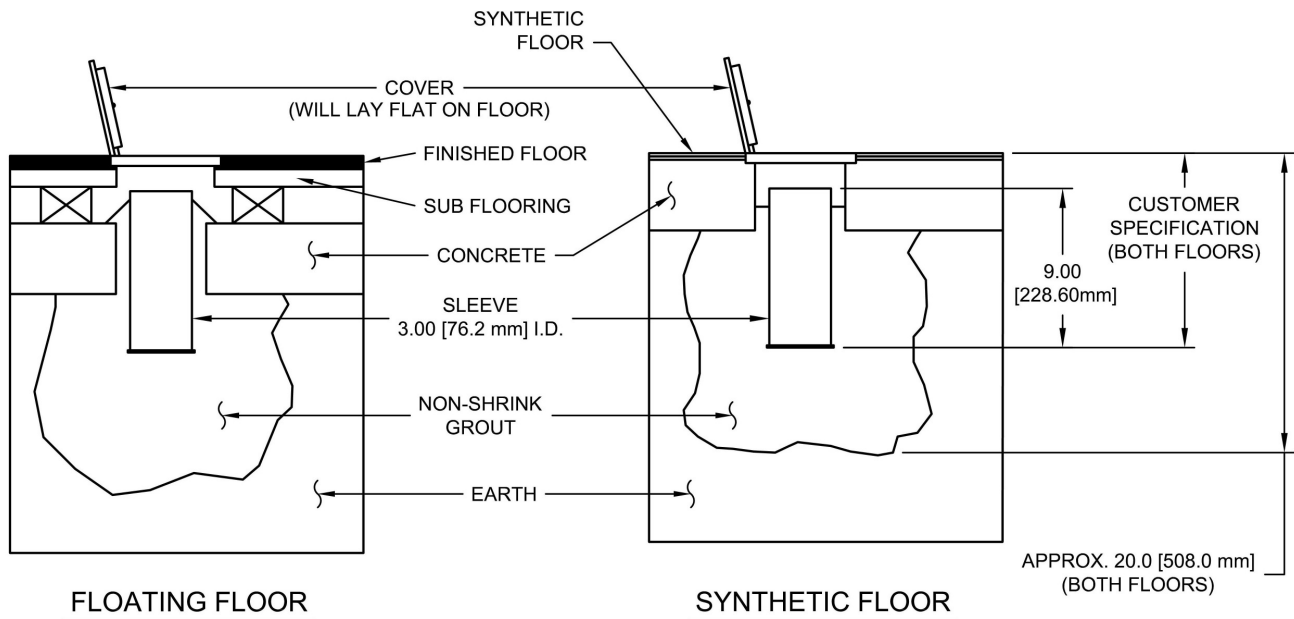

## 3" DIAMETER FLOOR SLEEVE

Models: 6404



### **Installation, Operation and Maintenance Instructions**

**Please read all instructions before attempting installation or operation of these units**

**SAVE THESE INSTRUCTIONS FOR FUTURE USE**

PUBLICATION No.  
601751272

January 15 2013



## 6404 3" DIAMETER FLOOR SLEEVE



1. Mark (2) spots on the floor exactly 36 feet apart (refer to most recent set of architectural prints for exact locations within the gym). These represent the CENTERS of each sleeve installation. If sleeves are to be more or less than 36 feet apart, contact a Gared representative for information regarding this alteration.
2. Cut (2) round holes through the playing surface 4-3/4" to 5", diameter centered on the spots marked in step one.
3. After cutting out the circle in the surface flooring, cut a similar hole in the concrete slab below. The diameter of this hole should be between 4-3/4" to 5"; however the size is not critical. The hole must be large enough to accommodate the sleeve.
4. When drilling the hole in concrete, the slab must be fully penetrated. Under the slab, hollow out (by hand) an area about 16-20 inches from the playing surface. The hole should be about 6 to 8 inches deeper than the bottom of the sleeve once it is inserted.
5. It is recommended that a "non-shrink" grout be used to anchor the sleeve. Pour the grout mixture into the hole until it is just below the BOTTOM of the concrete hole. Cover the sleeve during installation to prevent debris from falling into it or grout from entering bottom of sleeve.
6. Insert the 3" diameter I.D. sleeve and work it down into the grout until the inside bottom of the sleeve is 11" below the TOP surface of the floor. Incorrect sleeve depth will result in a net height error.
7. Turn the ring and cover plate upside down and approximately center it over the hole. Holding it firmly in place, outline it on the floor. Note: The purpose in centering this ring and cover above the sleeve is to allow the post to pass through the sleeve below. It may be slightly off-center and still work. This oversized design facilitates any movement of the floor now or in the future.
8. Using a router and template, counter bore a hole 6-1/4" diameter to a depth of 9/16" to receive the floor plate top. A template can be made from a piece of Masonite or thick plastic. Make a hole in the template material so that when the router is used with it, (allowance is made for router base plate) the counter bored diameter is 6-1/4". Use a scrap board for practice and to check the outcome of the hole first.
9. Center the template over the 5" diameter hole. See following page for a possible template design. When marking the counter bored hole, keep pressure on the template at all times to prevent slippage.
10. To prevent slipping of the template during the routing, tape the template to the floor or apply continuous pressure to the template. Do not set the depth of the router at 9/16 immediately. Gradually work down to the depth at which the floor plate is flush with surface floor. Place the floor plate down into the hole several times so as to not make the hole too deep. When installed, the plate must be perfectly flush with the top surface of the floor.

11. Place the ring in the routed out portion of the hole. Inside the ring are (4) holes. Use wood screws provided in the holes to secure the ring to the floor. (Normally this will be located in such a fashion that the covers open away from the court, though this is not critical.
12. Wait a minimum of (7) days to allow the grout to completely cure before setting up the posts.

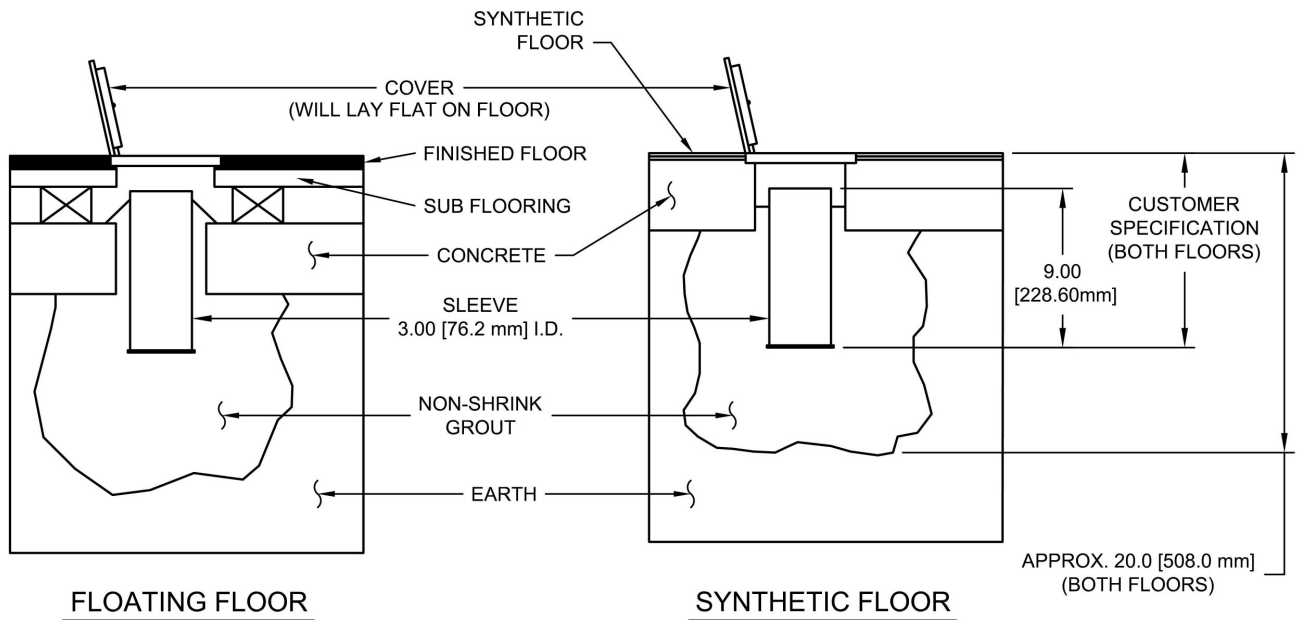

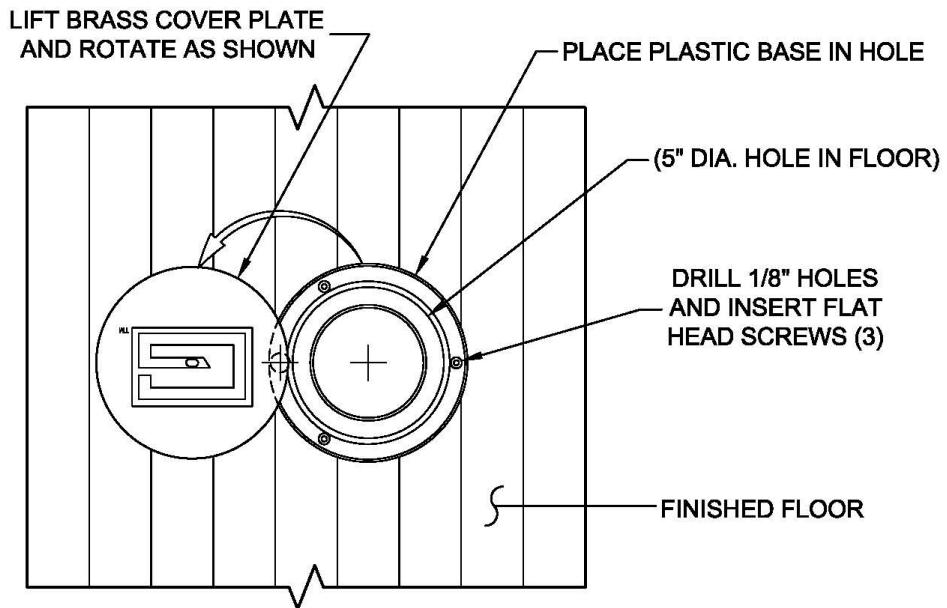
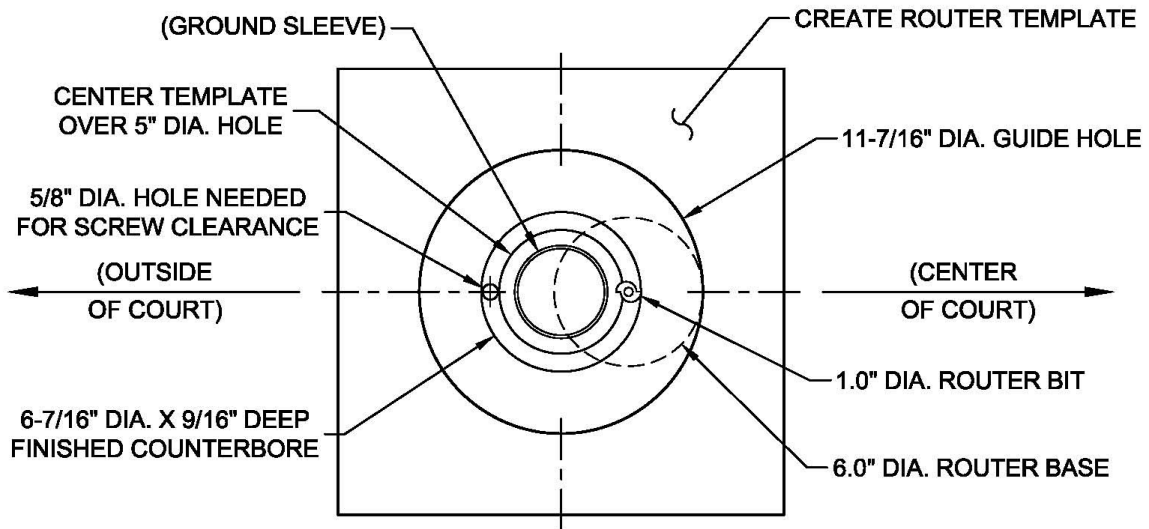

COVER SHOWN OPENING OUTWARD (AWAY FROM CENTER COURT)



**Gared Holdings, LLC**

**Performance Sports Systems**  
9200 E. 146<sup>th</sup> Street  
Noblesville, IN 46060

800-848-8034  
[www.perfsports.com](http://www.perfsports.com)

**Gared Sports**  
707 North 2<sup>nd</sup> Street  
St. Louis, MO 63102

800-325-2682  
[www.garedsports.com](http://www.garedsports.com)