

POSITIVE LOCK DETENT MECHANISM

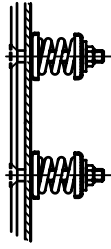

DUAL RETURN SPRINGS

Ø0.62 [15.88] STEEL ROD

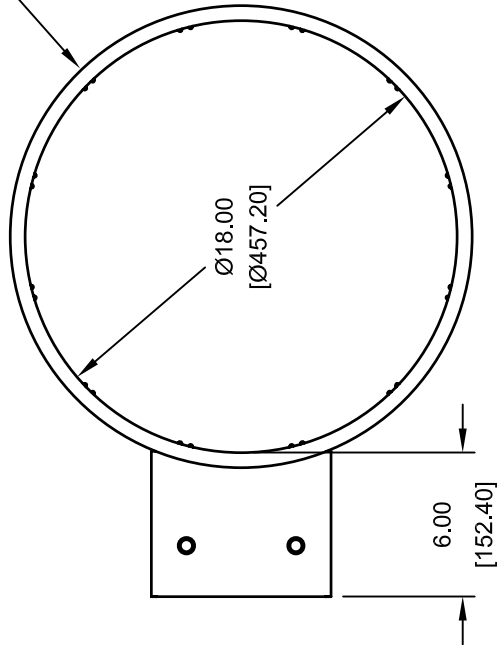

R0.22 [R5.56] TYP.

1.31 [33.34]

0.88 [22.23]

(TOP OF RIM)

6.31 [160.34]

4.00 [101.60]

5.00 [127.00]

5.00 [127.00]

7.00 [177.80]

R0.44 [R11.11] (2) PLACES

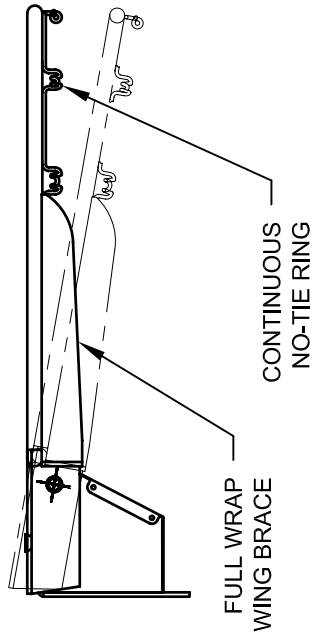

MOUNTING PLATE VIEW SCALE 2:1

NOTE:  
OFFICIAL ORANGE POWDER COAT FINISH.  
GOAL IS SUPPLIED WITH ANTI-WHIP NYLON NET AND MOUNTING HARDWARE.

REVISION		
REV.	DATE	BY
A	10/17/03	JJC
B	12/03/03	JJC
C	12/20/06	WAE
D	04/21/08	RWP

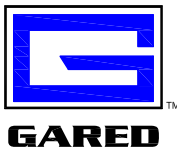

Gared Holdings, LLC  
9200 E. 146th St. Noblesville, IN 46060

THIS DOCUMENT CONTAINS TRADE SECRET AND OTHER MATERIALS WHICH ARE PROTECTED BY CONFIDENTIALITY NOTICE AND AGREEMENT AND BY COPYRIGHT. ANY USE OR COPYING OF THIS DOCUMENT EXCEPT AS AUTHORIZED BY GARED HOLDINGS, LLC IS STRICTLY PROHIBITED.

2000+ BREAKAWAY GOAL

DRAWN	CONNERLEY	DATE	05/08/03	MATERIAL	N/A
APPROVED	JJC	DATE	05/08/03	FINISH	AS NOTED
FILE LOC. Q:\Final Release\Specifications				DWG. NO.	2000
SIZE	SCALE	SHT. NO.	PART NO.	REV	
A	NONE	1 OF 1	2000	D	



## **MODEL 2000+**

### **POSITIVE LOCK BREAK-AWAY GOAL**

The 2000+ goal shall be constructed with an enclosed positive lock mechanism to hold rim in solid playing position. Goal shall be designed so that any possible entrapment areas have been eliminated.

Goal shall have official size 18" ring of 5/8" diameter steel with continuous no-tie net attachment, full wing brace design, and a durable orange powder coated finish. Anti-whip net and hardware shall be included. Hole spacing shall be 5" x 5". Goal shall meet NCAA and high school specifications.

#### **ACCESSORIES**

#### **BACKBOARDS**

Compatible backboards are models LXP4200, AFRG42, RG, AFRG48, FSGII, 1301B, 1342B, 1370B, 1401B, 1442B, 3010RG, 3011RG, ARG, 3050RG, BB48A38, BB60A38, BB60G38, BB72A38, BB72G50, and GP72422. See backboard section in specification manual.