

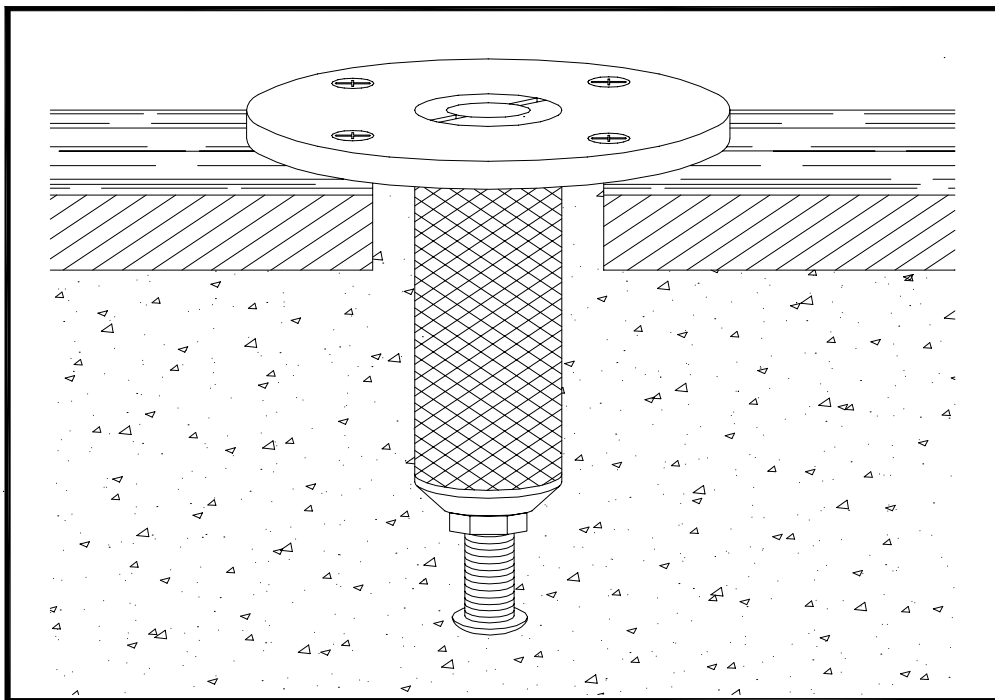

Performance Sports Systems  
9200 E. 146<sup>th</sup> Street, Suite A  
Noblesville, IN 46060

(800) 848-8034

## ASSEMBLY INSTRUCTIONS



## STYLE "BX" FLOOR PLATE

MODEL NUMBER

0422211

LAST REVISION DATE

10-25-95

INSTRUCTION SHEET NUMBER

0081517

ASSEMBLY PARTS LIST

KEY	PART #	DESCRIPTION	QTY
1	0021104	1/4X1-1/2" TAP SCREW	4
2	0020705	1/2 X 3/4 CAP SCREW	1
3	0049577	"BX" PLATE ASSEMBLY	1
4	0049802	SET 45 BAG ASSEMBLY	1

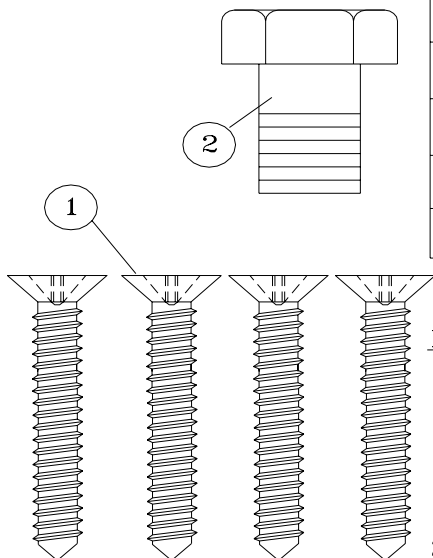

BEFORE YOU BEGIN INSTALLATION

1. YOUR "BX" PLATE COMES IN ONE PACKAGE. MAKE SURE YOU HAVE RECEIVED ALL THE PARTS LISTED ABOVE. THE CAP SCREW IS USED TO AID IN CORRECT INSTALLATION.

2. YOU WILL NEED THE FOLLOWING TOOLS AVAILABLE DURING INSTALLATION:

- HAMMER DRILL
- 1-1/8" MASONRY BIT
- REGULAR DRILL W/ 1-1/8" WOOD DRILL BIT & ONE 5/32" DRILL BIT
- ROUTER
- SCREWDRIVER W/ WIDE BLADE
- MIXING CONTAINER AND WATER
- SMALL VACUUM CLEANER, TIRE PUMP OR BATTERY FILLER
- STIFF CIRCULAR BRUSH
- PUTTY KNIFE
- ABSORBENT RAG

3. READ ALL INSTRUCTIONS CAREFULLY BEFORE STARTING INSTALLATION. CALL AAI WITH ANY QUESTIONS ON PROPER INSTALLATION.

**CAUTION: IMPROPER INSTALLATION CAN CREATE A HAZARD WHEN THESE PLATES ARE USED WITH APPARATUS. FOLLOW DIRECTIONS CAREFULLY.**

INSTALLATION INSTRUCTION

1. LOCATE AND MARK THE CENTER LOCATIONS OF THE FLOOR PLATES USING THE LAYOUT DIAGRAM PROVIDED WITH THE APPARATUS TO BE INSTALLED. RECHECK ALL CENTER LOCATIONS FOR ACCURACY BEFORE INSTALLING THE PLATES.

2. USING THE 1-1/8" WOOD DRILL BIT, DRILL A HOLE IN THE WOOD FLOOR AND SUB-FLOOR DOWN TO THE CONCRETE SURFACE.

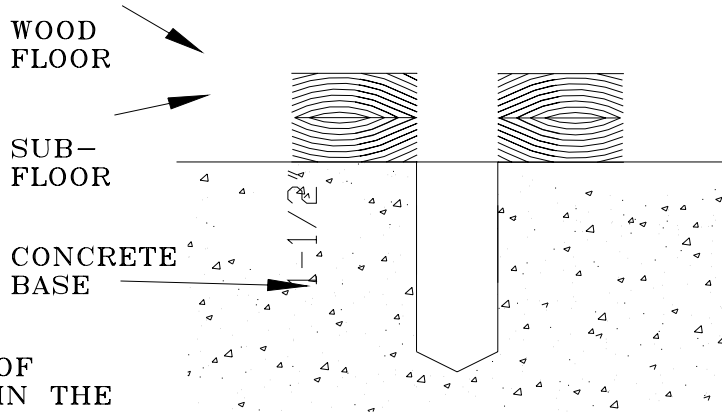

3. NEXT, USE THE 1-1/8" MASONRY BIT AND DRILL TO A MINIMUM DEPTH OF 4-3/4" AS SHOWN IN THE ADJACENT FIGURE.

4. MAKE A TEMPLATE USING A PIECE OF MASONITE OR THICK PLASTIC. MAKE A HOLE IN THE TEMPLATE MATERIAL SO THAT WHEN THE ROUTER IS USED WITH IT, THE COUNTER BORED DIAMETER IS 2-29/32". USE A SCRAP BOARD FOR PRACTICE AND FOR CHECKING THE OUTCOME OF THE HOLE BEFORE ATTEMPTING THIS IN YOUR FLOOR.

5. DRILL A COUNTER BORED HOLE 2-29/32" IN DIAMETER AND 1/4" DEEP CENTERED ON THE 1-1/8" HOLE ALREADY DRILLED. SEE FIGURE. WHEN MAKING THE COUNTER BORED HOLE, KEEP PRESSURE ON THE TEMPLATE AT ALL TIMES. THIS WILL KEEP THE TEMPLATE FROM SLIPPING AND ALSO THE WOOD FLOOR AROUND THE FLOOR PLATE WILL NOT SPLINTER. DO NOT SET THE DEPTH OF THE ROUTER AT 1/4" IMMEDIATELY. GRADUALLY WORK DOWN TO THE DEPTH AT WHICH THE FLOOR PLATE IS JUST FLUSH WITH THE SURFACE OF THE FLOOR. PLACE THE FLOOR PLATE DOWN INTO THE HOLE SEVERAL TIMES AS A CHECK SO YOU DON'T MAKE THE HOLE TOO DEEP. WHEN INSTALLED, THE FLOOR PLATE MUST BE PERFECTLY FLUSH WITH THE TOP SURFACE OF THE FLOOR.

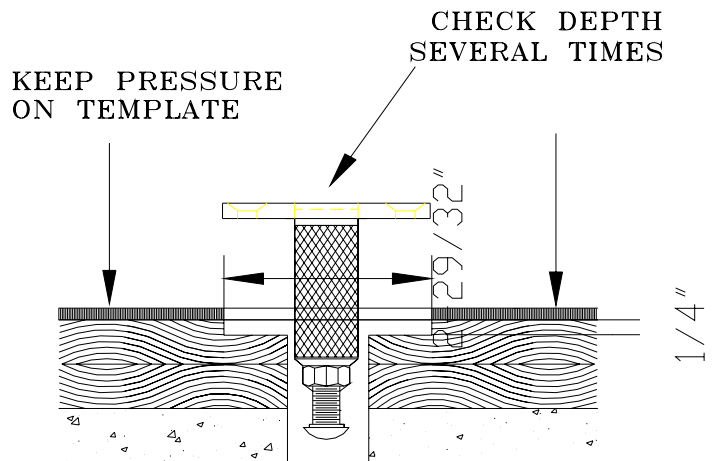

6. NEXT, COMPLETELY REMOVE THE DUST FROM THE HOLE BY SUCKING IT OUT WITH A SMALL VACUUM CLEANER OR BLOWING IT OUT WITH A TIRE PUMP OR BATTERY FILLER.

7. FILL THE HOLE WITH WATER. SCRUB THE SIDES AND BOTTOM WITH A STIFF CIRCULAR BRUSH SUCH AS A BOTTLE BRUSH. THIS IS IMPORTANT!!
8. REMOVE EXCESS WATER AND ANY LOOSE PARTICLES WITH A RAG OR OTHER ABSORBENT MATERIAL. LEAVE THE HOLE CLEAN AND UNIFORMLY DAMP.
9. MIX THE SET-45 IN A CLEAN CONTAINER. FOR BEST RESULTS, MEASURE ACCURATELY. THE CORRECT MIX RATIO IS ONE (1) OZ. (30 ML) WATER TO ONE (1) BAG SET-45. NOTE: MIX TO A THICK PASTE. LET MIXTURE STAND FOR ABOUT ONE MINUTE, THEN STIR THOROUGHLY. AT THIS POINT THE MIXTURE WILL BECOME MORE FLUID.

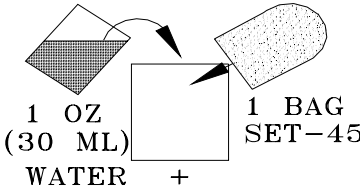

DO NOT ADD SAND, GRAVEL OR OTHER FOREIGN SUBSTANCES TO THE SET-45. THEY WEAKEN THE CEMENT AND AFFECT THE SETTING.

DO NOT ADD TOO MUCH WATER OR RETEMPER CEMENT WHICH HAS BEGUN TO SET UP IN A CONTAINER WITH ADDITIONAL WATER. THIS WILL RESULT IN FAILURE OF THE CEMENT TO ATTAIN PROPER STRENGTH.

10. TURN THE CAP SCREW INTO THE FLOOR PLATE UNTIL IT IS JUST FINGER TIGHT.

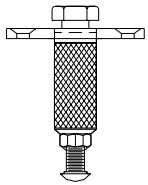

11. POUR THE SET-45 MIXTURE INTO THE HOLE UNTIL IT IS APPROXIMATELY 3/4 FULL.

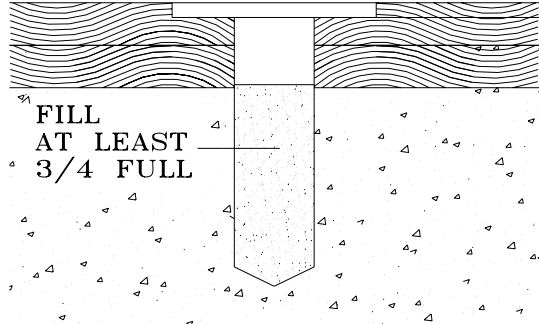

12. DIP THE FLOOR PLATE BODY IN WATER TO WET THE OUTER SURFACE, BUT DO NOT LET ANY WATER GET INTO THE FLOOR PLATE. SLOWLY INSERT THE FLOOR PLATE INTO THE HOLE. LOWER IT UNTIL THE TOP PLATE IS SEATED PROPERLY IN THE COUNTER BORED HOLE.. EXCESS SET-45 MIXTURE SHOULD FLOW OUT AROUND THE TOP PLATE! IF NOT, MORE CEMENT MIXTURE SHOULD BE ADDED. SCRAPE THE EXCESS CEMENT MIXTURE FROM AROUND THE OUTSIDE WITH A PUTTY KNIFE OR SCRAPER.

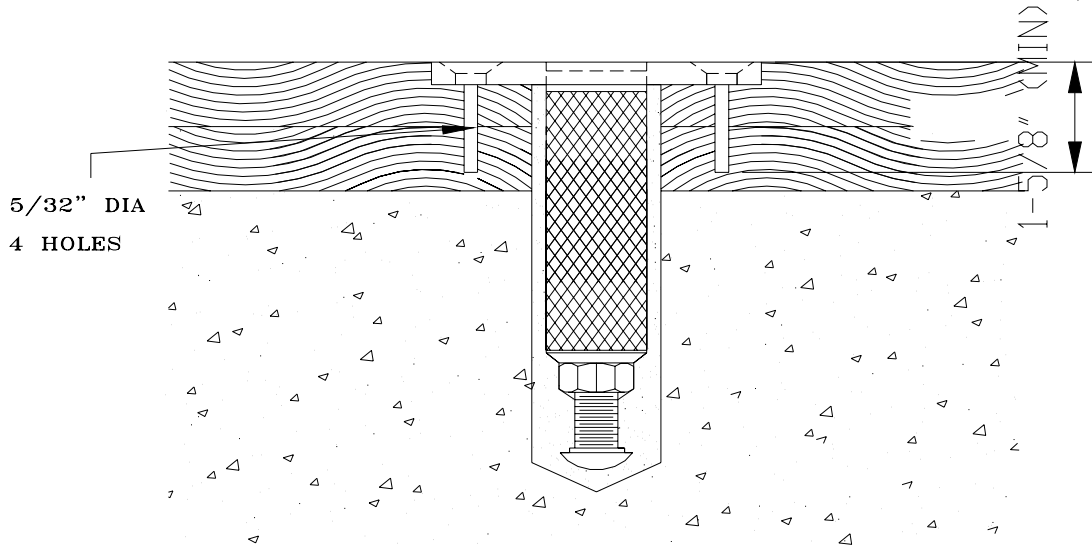

13. USING THE 5/32" DRILL BIT, DRILL FOUR HOLES IN THE WOOD FLOOR 1-5/8" DEEP TO RECEIVE THE SCREWS. USE THE FOUR HOLES IN THE TOP OF THE FLOOR PLATE AS GUIDES FOR DRILLING. TURN IN THE WOOD SCREWS MAKING SURE THEY ARE STRAIGHT AND SEATED PROPERLY.
14. AFTER 15 MINUTES, THE CEMENT AND FLOOR PLATE ARE INITIALLY SET. CAREFULLY REMOVE THE CAP SCREW FROM THE FLOOR PLATE.
15. ALLOW 12 HOURS FROM INSTALLATION TIME TO COMPLETE SETTING. AFTER 12 HOURS, APPARATUS MAY BE SET UP AND USED WITH THE FLOOR PLATES.
16. WHEN INSTALLING THE EYE SCREWS TO BE USED WITH THE APPARATUS, TURN THEM IN FINGER TIGHT. NO TOOLS ARE NECESSARY FOR THIS OPERATION. AFTER THE EYE SCREW HAS BEEN TURNED IN ALL THE WAY, TURN IT BACK JUST FAR ENOUGH TO ALLOW PROPER ALIGNMENT BETWEEN THE EYE SCREW AND THE ATTACHING HARDWARE.

#### USE OF YOUR "BX" PLATES

1. THESE FLOOR PLATES ARE INTENDED FOR USE IN CONCRETE FLOOR WITH MULTIPLE LAYERS OF WOOD INSTALLED DIRECTLY OVER CONCRETE. IT IS NOT INTENDED FOR USE WITH FLOATING FLOORS OR CONCRETE ONLY. IF THERE IS ANY QUESTION ABOUT THE APPROPRIATE FLOOR PLATE FOR YOUR FLOOR SURFACE, CONTACT PERFORMANCE SPORTS SYSTEMS FOR ASSISTANCE BEFORE INSTALLING.
2. YOUR FLOOR PLATES SHOULD BE CLEANED AND INSPECTED PERIODICALLY TO ENSURE THERE IS FULL ENGAGEMENT OF THE EYE SCREW THREADS AND THAT THERE IS NO BREAK-DOWN OF THE CEMENT OR FLOOR PLATE. PROPERLY INSTALLED, THESE FLOOR PLATES SHOULD WITHSTAND ANY LOADS APPLIED BY THE APPARATUS.
3. IF THERE IS ANY DOUBT AS TO THE INTEGRITY OF YOUR FLOOR PLATES, DO NOT USE THEM. CONTACT PERFORMANCE SPORTS SYSTEMS OR A PROFESSIONAL INSTALLER FOR AN EVALUATION.

REPLACEMENT PARTS LIST

KEY	PART #	DESCRIPTION
1	9919003	CHROMED REMOVEABLE CAP
2	9919002	CHROMED FLOOR PLATE PLUG
3	0022006	EXTERNAL E-RING
4	0015030	FLOOR PLATE SPRING
5	9949578	CHROMED FLOOR PLATE WELDMENT
6	0019130	FLOOR PLATE ANCHOR SCREW
7	0020420	3/8" HEX NUT
8	0021330	3/8" X 1-1/2" CARRIAGE BOLT
9	0021104	1/4" X 1-1/2" TAP SCREW

