

GARED

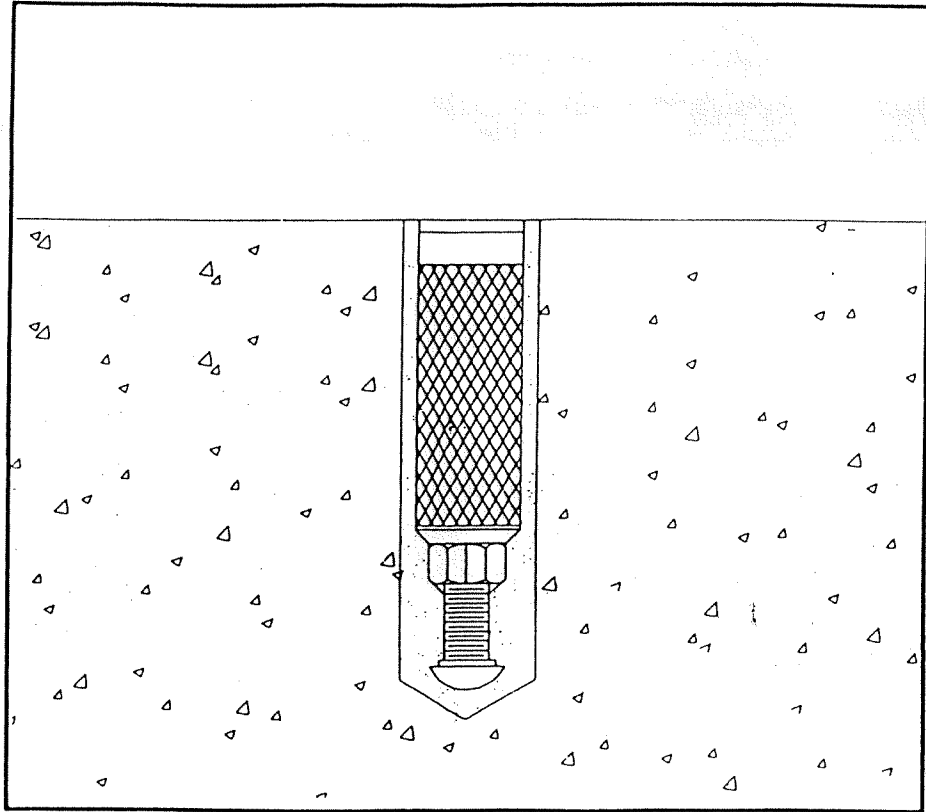

ASSEMBLY INSTRUCTIONS



STYLE "C" FLOOR PLATE

Gared Holdings, LLC
9200 East 146th Street, Suite A
Noblesville, Indiana 46060
317-774-9840

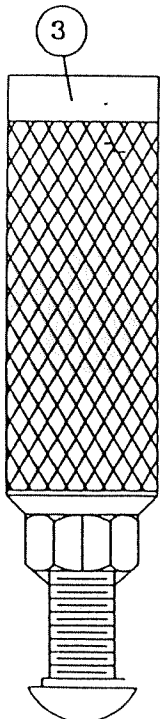
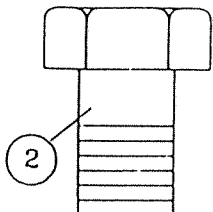
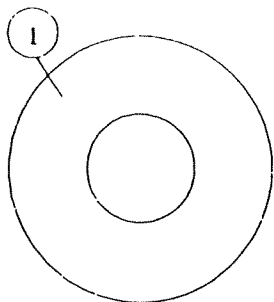

ASSEMBLY PARTS LIST

KEY	PART #	DESCRIPTION	QTY
1	0020690	1/2" FLAT WASHER	1
2	0020705	1/2 X 3/4 CAP SCREW	1
3	0049064	"C" PLATE ASSEMBLY	1
4	0049802	SET 45 BAG ASSEMBLY	1

BEFORE YOU BEGIN INSTALLATION

1. YOUR "C" PLATE COMES IN ONE PACKAGE. MAKE SURE YOU HAVE RECEIVED ALL THE PARTS LISTED ABOVE. THE WASHER AND CAP SCREW ARE USED TO AID IN CORRECT INSTALLATION.

2. YOU WILL NEED THE FOLLOWING TOOLS AVAILABLE DURING INSTALLATION:

HAMMER DRILL
 1-1/8" MASONRY BIT
 MIXING CONTAINER AND WATER
 SMALL VACUUM CLEANER, TIRE PUMP OR BATTERY FILLER
 STIFF CIRCULAR BRUSH
 PUTTY KNIFE
 ABSORBENT RAG

3. READ ALL INSTRUCTIONS CAREFULLY BEFORE STARTING INSTALLATION. CALL AAI WITH ANY QUESTIONS ON PROPER INSTALLATION.

CAUTION: IMPROPER INSTALLATION CAN CREATE A HAZARD WHEN THESE PLATES ARE USED WITH APPARATUS. FOLLOW DIRECTIONS CAREFULLY.

INSTALLATION INSTRUCTION

1. LOCATE AND MARK THE CENTER LOCATIONS OF THE FLOOR PLATES USING THE LAYOUT DIAGRAM PROVIDED WITH THE APPARATUS TO BE INSTALLED. RECHECK ALL CENTER LOCATIONS FOR ACCURACY BEFORE INSTALLING THE PLATES.
2. USING THE 1/2" FLAT WASHER AS A TEMPLATE, MARK A CIRCLE CENTERED ON THE FLOOR PLATE LOCATION WITH A PENCIL OR FELT TIP MARKER. THIS WILL BE USED LATER AS A GUIDE FOR CENTERING THE FLOOR PLATE.

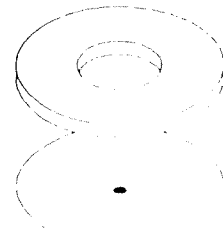

3. DRILL A HOLE IN THE MARKED LOCATION USING A HAMMER DRILL AND A 1-1/8" MASONRY BIT. DRILL THE HOLE TO A MINIMUM DEPTH OF 3-3/4". IF THE CONCRETE THICKNESS IN YOUR FLOOR IS LESS THAN 3-3/4", CONTACT THE FACTORY FOR FURTHER ADVICE.

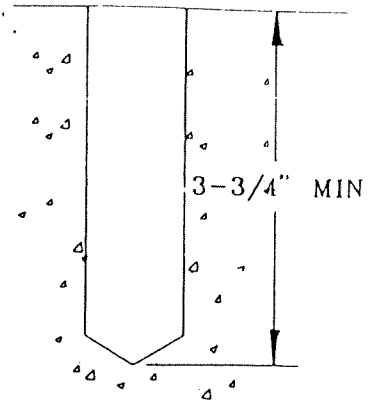

4. COMPLETELY REMOVE THE DUST FROM THE HOLE BY SUCKING IT OUT WITH A SMALL VACUUM CLEANER OR BLOWING IT OUT WITH A TIRE PUMP OR BATTERY FILLER.
5. FILL THE HOLE WITH WATER. SCRUB THE SIDES AND BOTTOM WITH A STIFF CIRCULAR BRUSH SUCH AS A BOTTLE BRUSH. THIS IS IMPORTANT!!
6. REMOVE EXCESS WATER AND ANY LOOSE PARTICLES WITH A RAG OR OTHER ABSORBENT MATERIAL. LEAVE THE HOLE CLEAN AND UNIFORMLY DAMP.

7. MIX THE SET-45 IN A CLEAN CONTAINER. FOR BEST RESULTS, MEASURE ACCURATELY. THE CORRECT MIX RATIO IS ONE (1) OZ. (30 ML) WATER TO ONE (1) BAG SET-45. NOTE: MIX TO A THICK PASTE. LET MIXTURE STAND FOR ABOUT ONE MINUTE, THEN STIR THOROUGHLY. AT THIS POINT THE MIXTURE WILL BECOME MORE FLUID.

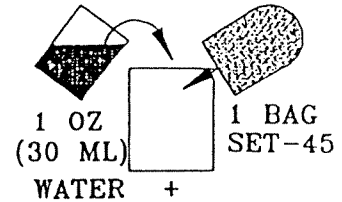

DO NOT ADD SAND, GRAVEL OR OTHER FOREIGN SUBSTANCES TO THE SET-45. THEY WEAKEN THE CEMENT AND AFFECT THE SETTING.

DO NOT ADD TOO MUCH WATER OR RETEMPER CEMENT WHICH HAS BEGUN TO SET UP IN A CONTAINER WITH ADDITIONAL WATER. THIS WILL RESULT IN FAILURE OF THE CEMENT TO ATTAIN PROPER STRENGTH.

8. PUT THE FLAT WASHER ON THE 3/4" CAP SCREW. TURN THE CAP SCREW INTO THE FLOOR PLATE UNTIL IT IS JUST FINGER TIGHT.



9. POUR THE SET-45 MIXTURE INTO THE HOLE UNTIL IT IS APPROXIMATELY 3/4 FULL.

FILL AT LEAST 3/4 FULL

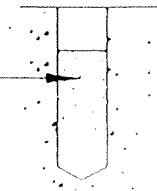

10. DIP THE FLOOR PLATE IN WATER TO WET THE OUTER SURFACE, BUT DO NOT LET ANY WATER GET INTO THE FLOOR PLATE. SLOWLY INSERT THE FLOOR PLATE ASSEMBLY INTO THE HOLE, KEEPING THE WASHER CENTERED AROUND THE PRE-MARKED CIRCLE. LOWER IT UNTIL THE WASHER IS FLUSH WITH THE FLOOR SURFACE. EXCESS SET-45 MIXTURE SHOULD FLOW OUT AROUND THE WASHER!! IF NOT, MORE CEMENT MIXTURE SHOULD BE ADDED. SCRAPE THE EXCESS CEMENT MIXTURE FROM AROUND THE WASHER WITH A PUTTY KNIFE OR SCRAPER.

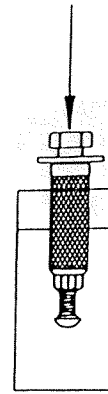

DIP IN WATER

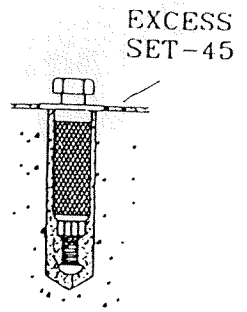

INSERT IN HOLE

11. AFTER 15 MINUTES, THE CEMENT AND FLOOR PLATE ARE INITIALLY SET. CAREFULLY REMOVE THE CAP SCREW AND WASHER FROM THE FLOOR PLATE. USING THE PUTTY KNIFE OR SCRAPER, SMOOTH OUT THE SET-45 AROUND THE FLOOR PLATE FOR AN EVEN FINISH.
12. ALLOW 12 HOURS FROM INSTALLATION TIME TO COMPLETE SETTING. AFTER 12 HOURS, APPARATUS MAY BE SET UP AND USED WITH THE FLOOR PLATES.
13. WHEN INSTALLING THE EYE SCREWS TO BE USED WITH THE APPARATUS, TURN THEM IN FINGER TIGHT. NO TOOLS ARE NECESSARY FOR THIS OPERATION. AFTER THE EYE SCREW HAS BEEN TURNED IN ALL THE WAY, TURN IT BACK JUST FAR ENOUGH TO ALLOW PROPER ALIGNMENT BETWEEN THE EYE SCREW AND THE ATTACHING HARDWARE.

USE OF YOUR "C" PLATES

1. THESE FLOOR PLATES ARE INTENDED FOR USE IN CONCRETE FLOORS AND CAN BE USED WITH ALL AAI CABLED GYMNASTICS EQUIPMENT AS WELL AS WITH AAI T-BASE VOLLEYBALL SYSTEMS.
2. YOUR "C" PLATES SHOULD BE CLEANED AND INSPECTED PERIODICALLY TO ENSURE THERE IS FULL ENGAGEMENT OF THE THREADS OF THE EYEBOLTS AND THAT THERE IS NO BREAK-DOWN OF THE CEMENT. WITH PROPER INSTALLATION, THE SET-45 INSTALLATION SHOULD WITHSTAND ANY LOADS APPLIED BY THE APPARATUS RECOMMENDED FOR THESE FLOOR PLATES.
3. IF THERE IS ANY DOUBT AS TO THE INTEGRITY OF YOUR FLOOR PLATES, DO NOT USE THEM. CONTACT AAI OR A PROFESSIONAL INSTALLER FOR EVALUATION.



REPLACEMENT PARTS LIST

KEY	PART #	DESCRIPTION
1	9919003	CHROMED REMOVEABLE CAP
2	9919002	CHROMED FLOOR PLATE PLUG
3	0022006	EXTERNAL E-RING
4	0015030	FLOOR PLATE SPRING
5	9919001	CHROMED FLOOR PLATE BODY
6	0019130	FLOOR PLATE ANCHOR SCREW
7	0020420	3/8" HEX NUT
8	0021330	3/8" X 1-1/2" CARRIAGE BOLT

