

FURRING STRIPS
BY OTHERS HIGHLY RECOMMENDED

NOTE:
ALL CUSTOM CUTTING AND
FITTING OF PANELS IS TO
BE DONE IN THE FIELD TO
ENSURE A PRECISE FIT.

14 OZ MIN POLYESTER LAMINATED
VINYL ATTACHED TO BACKING WITH
STAPLES EVERY 2"

2" [50.8mm]
POLYURETHANE FOAM

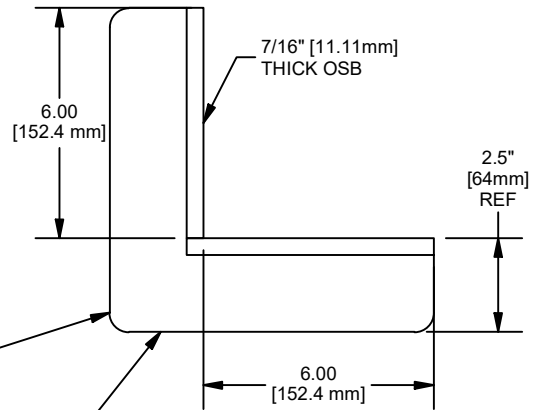

Part number	"A" Dim	"B" Dim
4310-STD	5'-10" [1778mm]	6'-0" [1829 mm]
4310-NSD	6'-10" [2082 mm]	7'-0" [2134mm]
4310-NSD	7'-10" [2388 mm]	8'-0" [2438 mm]

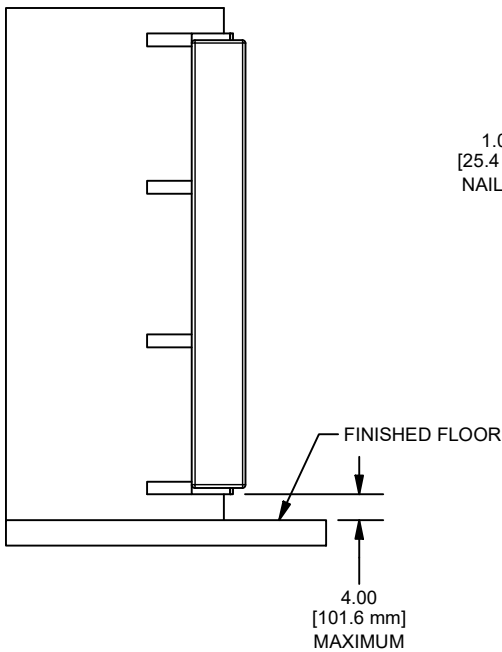

1.00
[25.4 mm]
NAIL LIP

FINISHED FLOOR
4.00
[101.6 mm]
MAXIMUM

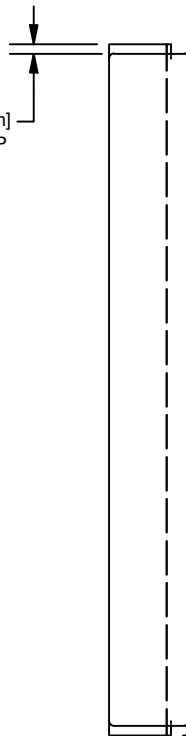

1.00
[25.4 mm]
NAIL LIP

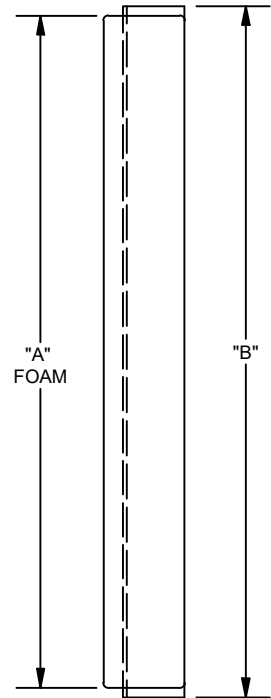

"A"
FOAM

"B"

WARNING
DO NOT INSTALL PADS MORE THAN 4" ABOVE
THE FINISHED FLOOR. INSTALLING PADS
ABOVE 4" CAN RESULT IN BODY CONTACT
WITH THE WALL AND PERSONAL INJURY.



Gared Performance Sports Systems
9200 East 146th Street, Suite A
Noblesville, IN 46060

THIS DOCUMENT CONTAINS TRADE SECRET AND OTHER MATERIALS
WHICH ARE PROTECTED BY CONFIDENTIALITY NOTICE AND AGREEMENT
AND BY COPYRIGHT. ANY USE OR COPYING OF THIS DOCUMENT EXCEPT
AS AUTHORIZED BY GARED PERFORMANCE SPORTS SYSTEMS IS STRICTLY
PROHIBITED.

WALL PAD, CORNER

DRAWN MJP		DATE 1/28/2022	DATE ISSUED	
APPROVED		DATE		
SIZE A	SCALE NONE	SHT. NO. 1 OF 2	PART NO. 4310	REV B

B	CYC	09/26/23
A	MJP	01/28/22
REV	BY	DATE



PERFORMANCE SPORTS SYSTEMS

MODEL 4310

CORNER PADDING

Corner wall padding standard size (Part number 4310-STD) shall be 6"[152.4mm] x 6"[152.4mm] x 6' [1.82 m] with 1" [25.4 mm] nailing margin with height options (Part number 4310-NSD) available for both 6"[152.4mm] x 6"[152.4mm] x 7' [2.134 m] and 6"[152.4mm] x 6"[152.4mm] x 8' [2.438 mm] with 1" [25.4 mm] nailing margin on top and bottom of each panel. Nailing margin reduces foam height from 6' [1.8 m] to 5'-10" [1.77 m], 7' [2.134 m] to 6'-10" [2.083 m], and 8' [2.44 m] to 7'-10" [2.39 m] respectively. Pads shall be constructed using 2" [50.8 mm] thick 3.5 lbs. density polyurethane foam cemented to 7/16" [11.11 mm] oriented strand board.

Cover material shall be 14-ounce polyester laminated vinyl stapled to backing every two inches. Vinyl to be flame retardant material meeting NFPA 701, ASTM E84, and CSFM (California State Fire Marshal).

Vinyl shall be available in white, yellow, orange, red, kelly green, forest green, royal blue, marine blue, navy blue, gray, black, burgundy, beige, and purple.

Custom cutting and fitting of padding may be done in field to ensure proper fit. Furring strips by others (highly recommended).

ACCESSORIES

WALL ATTACHMENT TRIMS AND HARDWARE

Most wall padding may be attached with special attachment trims and hardware. See the wall padding section in the specification manual.

Subject to design change and current manufacturing practices.