

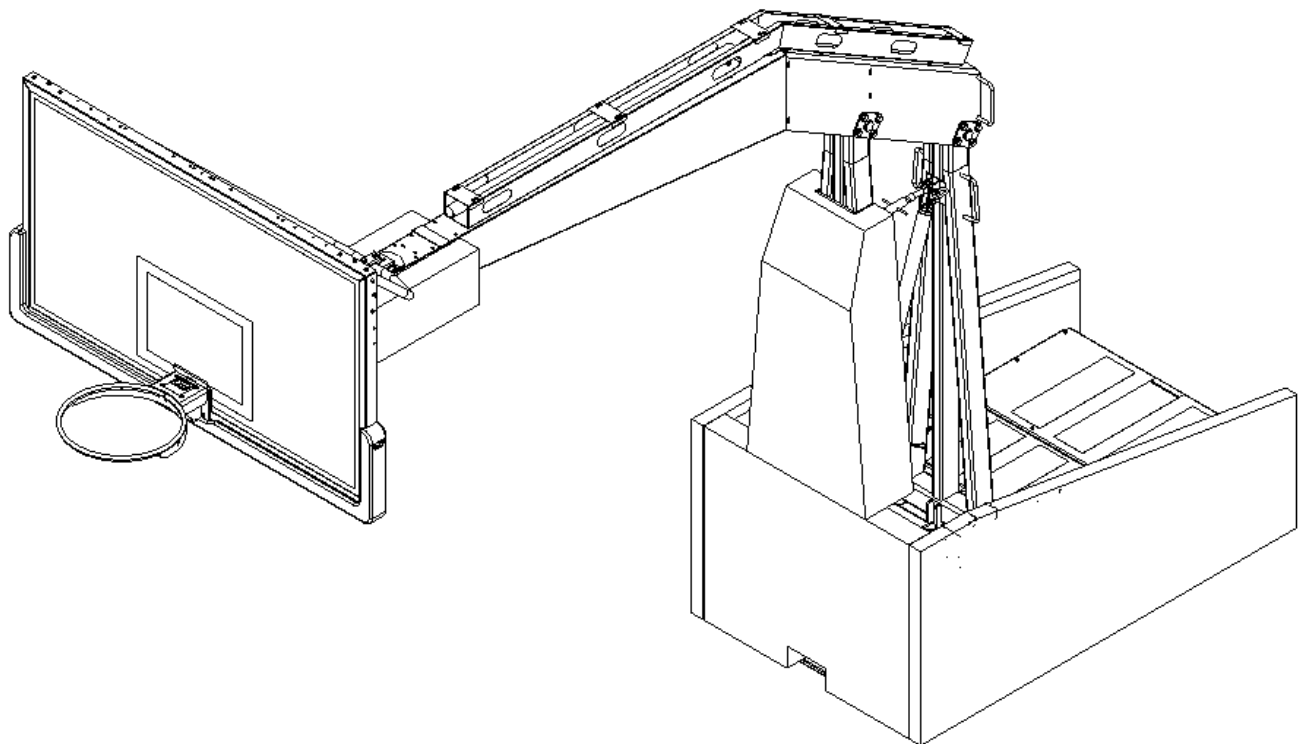

Gared Outer Limit Pro Portable Backstop

Models: 9716S, 9718S, 9716E & 9618E



Installation, Operation and Maintenance Instructions

.....
Please read all instructions before attempting installation or operation of these units
.....

SAVE THESE INSTRUCTIONS FOR FUTURE USE

PUBLICATION No.
551756323

Revised
July 12, 2022



Table of Contents

<u>Section</u>	<u>Page No.</u>
Introduction.....	1
Basic Dimensions.....	2
Cautions and Warnings.....	4
Parts Checklist	5
Installation.....	7
-Board and Goal Assy	8
-Locating and Adjusting Unit	11
-Pad Installation	15
Unit Operation	17
-Electric Lift Operation & Wiring Diagram	20
Maintenance.....	22
Troubleshooting.....	23

Introduction

Thank you for your purchase of a Gared Sports model Outer Limit Pro Portable backstop. To ensure that our equipment will provide years of use to you, we are including this installation, operation, and maintenance guide. This guide will provide information on the proper assembly and installation methods, operating procedures, and preventative maintenance of your portable backstop.

Please note that a Bill of Materials is being included with this guide. Please check that all of the parts called out on the Bill of Materials are present prior to beginning assembly and setup. Please do not substitute for factory parts. Please contact customer service department and allow them to determine if substitute parts are acceptable.

It is recommended that an individual who has been properly trained perform assembly and set up of the backstop. No one under the age of 18 should attempt assembly or set up of the unit, unless properly supervised.

To prevent normal wear and tear from shortening the life of the unit, preventative maintenance inspections and repairs should be performed at least once per year. If the units are subject to high or unusual usage, inspections should be scheduled to occur more frequently. If items are found to be nonconforming, replacements can be ordered from one of our authorized dealers. When contacting your dealer, please have information regarding the name of the project, and any applicable warranty information.

BASIC DIMENTIONS 9716S, 9716E (8'-0" F.O.B.)

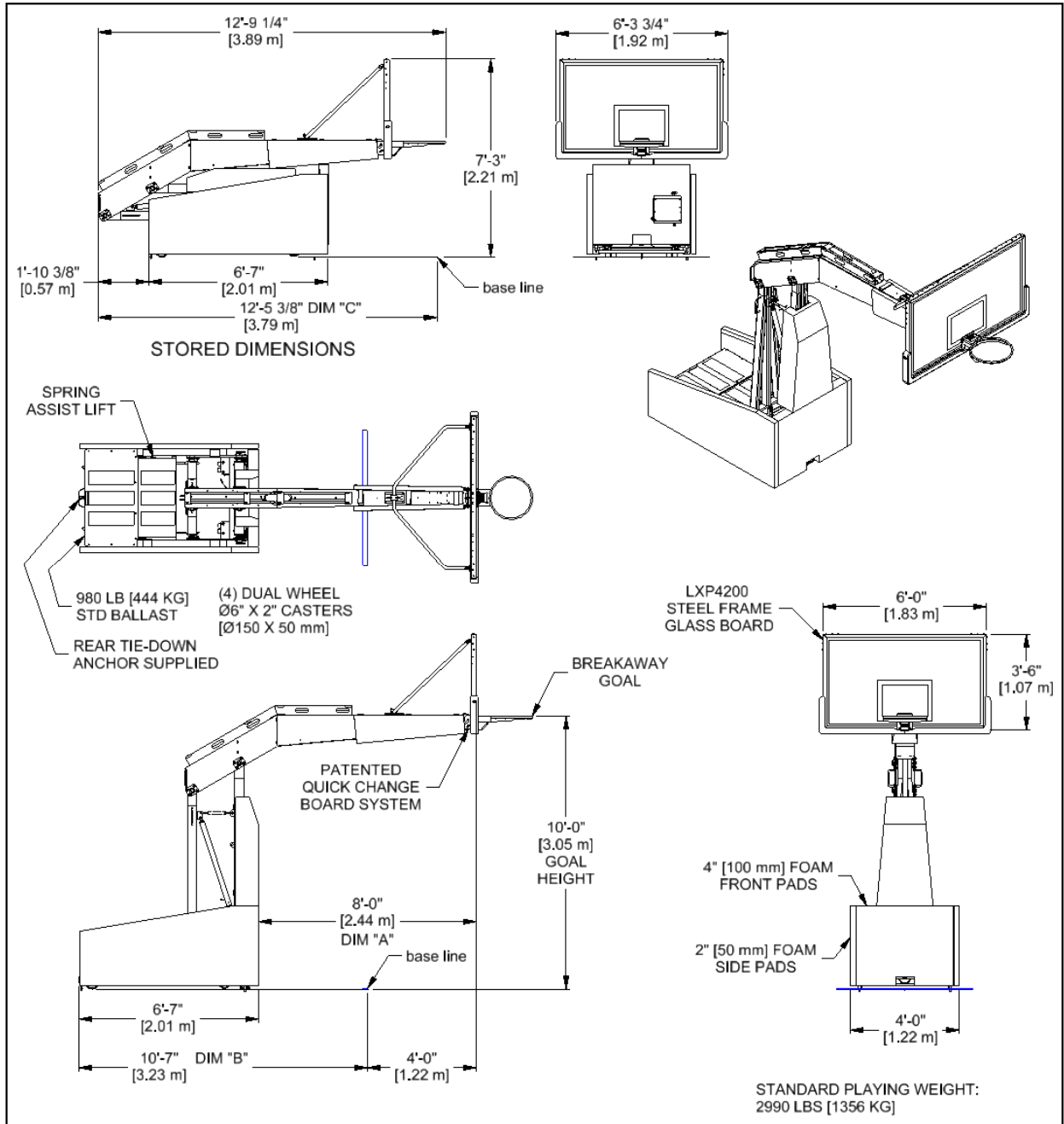

GOAL HT.	DIM "A"	DIM "B"	DIM "C"
10'-0" [3.048 m]	8'-0" [2.438 m]	10'-7" [3.226 m]	12'-5 3/8" [3.794 m]
9'-0" [2.743 m]	4'-8 1/2" [1.435 m]	7'-3 1/2" [2.223 m]	9'-1 7/8" [2.791 m]
8'-0" [2.438 m]	3'-7 7/8" [1.114 m]	6'-2 7/8" [1.902 m]	8'-1 1/4" [2.47 m]

MODEL	Play Weight
	lbs [Kg]
9716S	
w/ std ballast	2990 [1356 Kg]
w/ opt ballast	3460 [1569 Kg]
9716E	
w/ std ballast	3022 [1371 Kg]
w/ opt ballast	3492 [1584 Kg]

Play weight does not include added auxiliary equipment.
(shot clocks, signage, or camera equipment)

BASIC DIMENTIONS 9718S, 9718E (10'-8" F.O.B.)

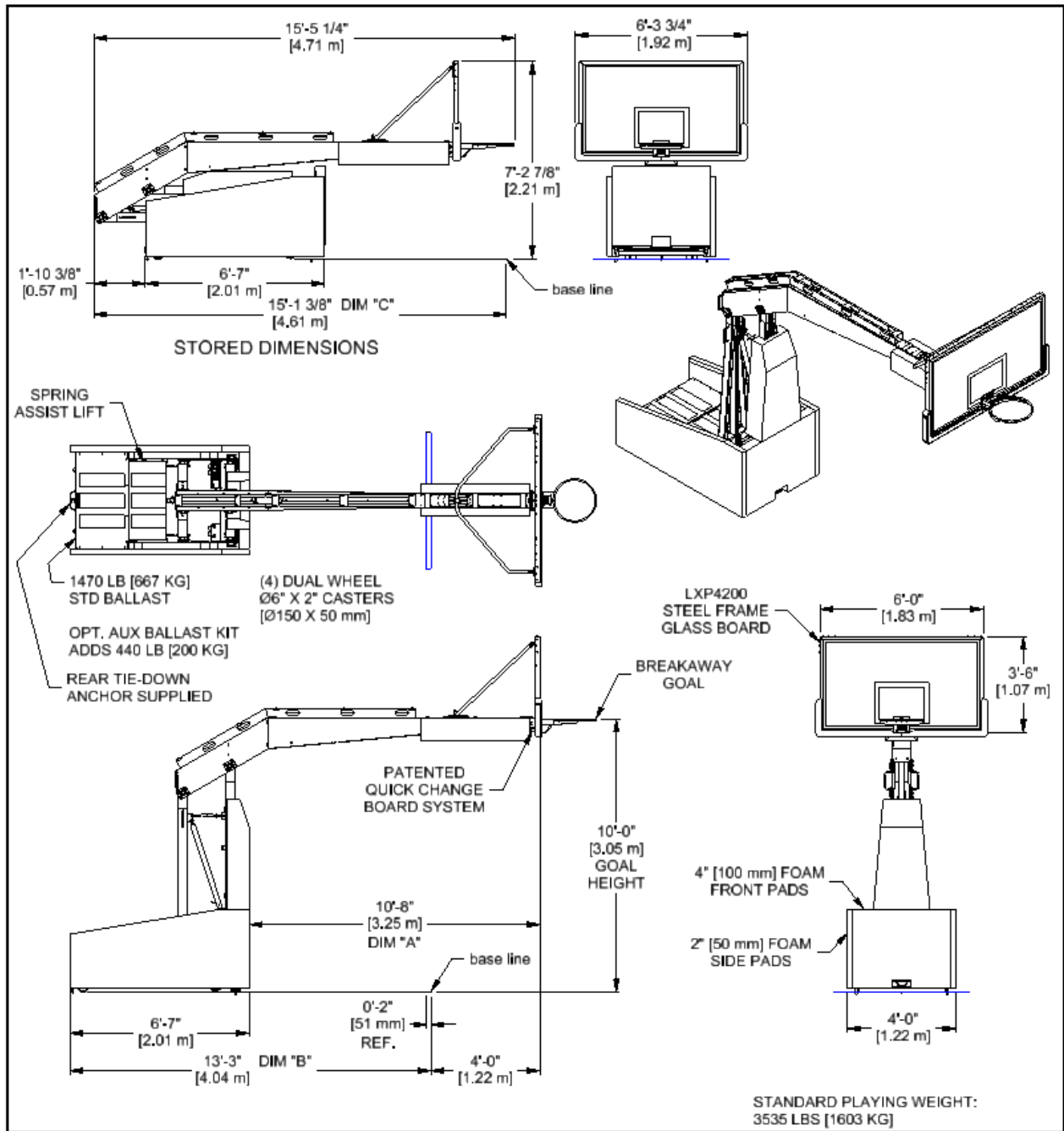

GOAL HT.	DIM "A"	DIM "B"	DIM "C"
10'-0" [3.048 m]	10'-8" [3.251 m]	13'-3" [4.039 m]	15'-1 3/8" [4.607 m]
9'-0" [2.743 m]	7'-4 1/2" [2.248 m]	9'-11 1/2" [3.035 m]	11'-9 7/8" [3.604 m]
8'-0" [2.438 m]	6'-3 7/8" [1.927 m]	8'-10 7/8" [2.715 m]	10'-9 1/4" [3.283 m]

MODEL	Play Weight lbs [Kg]
9718S	
w/ std ballast	3535 [1603 Kg]
w/ opt ballast	3975 [1803 Kg]
9718E	
w/ std ballast	3567 [1618 Kg]
w/ opt ballast	4007 [1817 Kg]

Play weight does not include added auxiliary equipment. (shot clocks, signage, or camera equipment)

Read and understand the following warnings to prevent possible personal injury and potential damage to the equipment during assembly, setup, and operation.

⚠ DANGER

DO NOT CLIMB ON GOAL, BANKBOARD OR BACKSTOP.

THIS UNIT IS DESIGNED FOR A SPECIFIC OPERATING WEIGHT AND THE ADDED WEIGHT COULD CAUSE DAMAGE AND/OR SERIOUS INJURY TO PERSONNEL.

2036-31-00

⚠ WARNING

DO NOT REMOVE SHIPPING BRACE BEFORE INSTALLING BACKBOARD AND GOAL. REMOVING BRACE WITHOUT BACKBOARD INSTALLED COULD RESULT IN SERIOUS PERSONAL INJURY AND/OR DAMAGE TO UNIT.

126453732

⚠ WARNING

REAR ANCHOR POINT MUST BE ATTACHED TO FLOOR ANCHOR AND FRONT LEVELING PADS MUST BE ON THE FLOOR WITH ALL WEIGHT OFF THE FRONT SWIVEL CASTERS BEFORE UNIT CAN BE USED FOR PLAY.

126453733

⚠ WARNING

DO NOT REMOVE BACKBOARD BEFORE INSTALLING SHIPPING BRACE ON MAIN BOOM. REMOVING BACKBOARD WITHOUT BRACE INSTALLED COULD RESULT IN SERIOUS PERSONAL INJURY AND/OR DAMAGE TO UNIT.

126453731

⚠ WARNING

SPRINGS ARE PRESET AT FACTORY. ADDITIONAL ADJUSTMENTS MUST BE DONE BY AUTHORIZED FACTORY PERSONNEL.

126453734

⚠ WARNING

SAFETY PIN MUST BE INSTALLED DURING USE, AND REMOVED PRIOR TO LOWERING UNIT.

126453736

⚠ CAUTION

MOVING PARTS! KEEP HANDS, ARMS, BODY CLEAR DURING OPERATION

124252799

⚠ CAUTION

KEEP PERSONNEL AWAY FROM FRONT AND REAR OF UNIT WHILE RAISING OR LOWERING THE BACKBOARD

126453737

⚠ CAUTION

DO NOT STAND OR SIT ON UNIT DURING OPERATION

126453735

⚠ CAUTION

ALWAYS LOWER BACKBOARD TO FULL DOWN POSITION BEFORE ATTEMPTING TO MOVE THE UNIT.

126453740

Before proceeding with assembly, **read all instructions and assembly procedures**. Make sure all parts have been received and are not damaged.



Gared Outer Limit Pro Portable Backstop



Parts Checklist

The following parts have been packed separately or installed on the unit. Verify all parts listed on packing list are present prior to installation. Because these units can use a variety of backboards and goals, the specific part number is not referenced in the table. Please refer to your packing slip to verify the correct board and goal has been received.

ITEM	PART NUMBER	DESCRIPTION	9716S/9716E	9718S/9718E	
1	501-6-16-16	BOLT, CARRIAGE 3/8-16 UNC X 1	4	4	
2	501-6-16-40	BOLT, CARRIAGE 3/8-16 UNC X 2.5	2	2	
3	502-6-16-16	HEX BOLT, 3/8-16 UNC X 1	2	2	
4	541-6-16	HEX NUT 3/8-16	6	6	
5	561-6	FLAT WASHER 3/8	2	2	
6	562-6	SPLIT LOCK WASHER 3/8	8	8	
7	6380-11-00	HITCH PIN, 1/8" DIA	2	2	
8	101653939	QUICK CHANGE LOCKING ROD	1	1	
9	111084108	CLEVIS PIN, 3/8" DIA X 1.125	2	2	
10	111094109	HITCH PIN CLIP FOR 3/8 DIA PINS	2	2	
11	556453270	BRACKET, BOARD BRACE CLAMP	1	1	
12	556453272	BACKBOARD BRACE	1	1	
13	556453273	BRACKET, BOARD BRACE MOUNTING	2	2	
14	556453576	PLATE, QUICK CHANGE FOR BOARD	1	1	
15		REC GLASS BACKBOARD	1	1	varies
16		GOAL, BREAKAWAY	1	1	varies
17	PMCE	PRO MOLD CUSHION EDGE	1	1	
18	101851023	3/4" OD X 5/8" ID X 1.00 L FLANGE BUSHING	2	2	
19		SPECIFY FLOOR ANCHOR TYPE NEEDED	1	1	varies
20	3005-15-05	TIE DOWN BOLT, REAR	1	1	
21	551756323	MANUAL, INSTALL & OPERATION 9716/18	1	1	
30	556566299	BRKT WELDMENT, SHIPPING BRACE	1	1	installed
31	502-8-13-24	HEX BOLT, 1/2-13 UNC X 1.5	4	4	installed
32	562-8	SPLIT LOCK WASHER 1/2	4	4	installed
33	561-8	FLAT WASHER 1/2	4	4	installed

PAD SET

ITEM	PART NUMBER	DESCRIPTION	9716S/9716E	9718S/9718E
		PAD SET	886565371	886565370
40.1	886565385	PAD, 98" BOOM	1	
40.1	886565384	PAD, 128" BOOM		1
40.2	886565372	PAD, FRONT LOWER	1	1
40.3	886565375	PAD, FRONT UPRIGHT	1	1
40.4	886565379	PAD, LH SIDE	1	1
40.5	886565380	PAD, RH SIDE	1	1
40.6	556566303	CLIP, 3" PAD	8	8
40.7	556566293	BRACKET, PAD HINGE	4	4
40.8	502-5-18-20	HEX BOLT, 5/16-18 UNC X 1.25	2	2
40.9	545-5-18Z	HEX NUT, NYLON LOCK 5/16-18	2	2
40.10	223-4-20-8Z	SCREW, MACH PAN HD PHIL 1/4-20 UNC X 0.5	24	24
40.11	561-4	FLAT WASHER 1/4	24	24

Contact Customer Service for assistance with replacement of any parts missing or damaged.

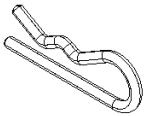
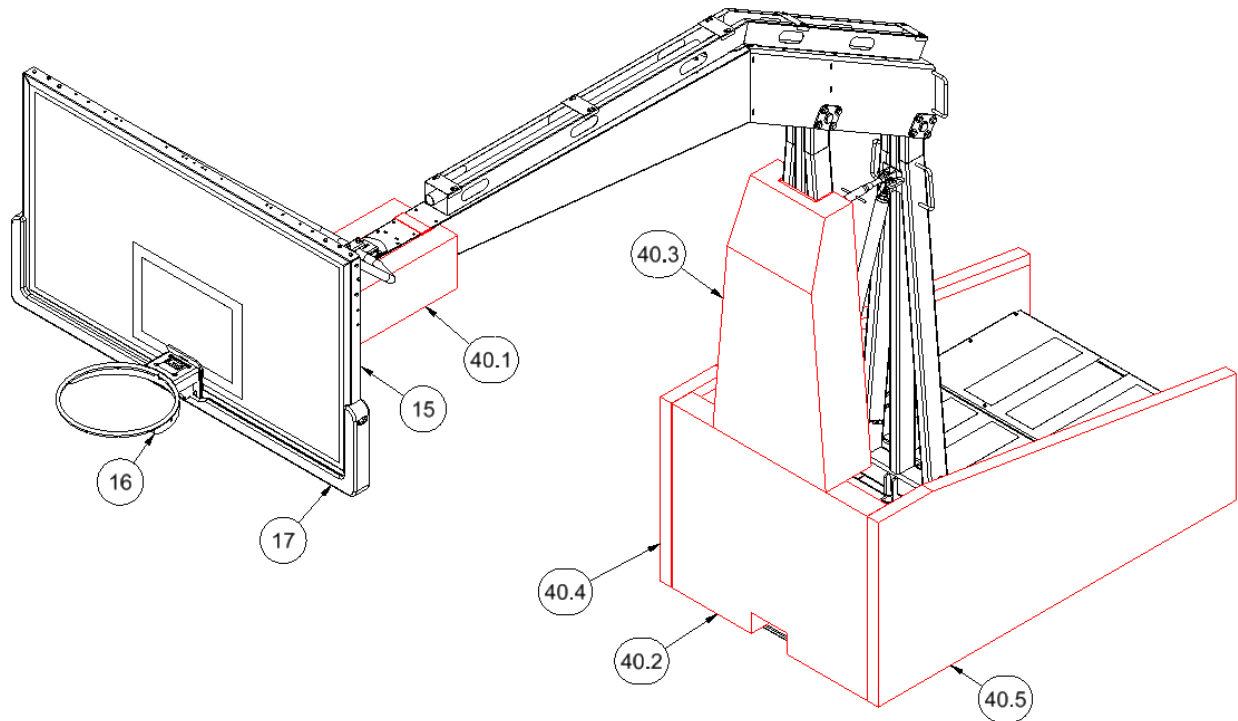

ITEM #7 6380-11-00

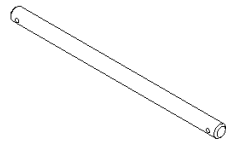

ITEM #8 101653939

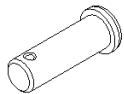

ITEM #9 111084108

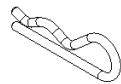

ITEM #10 111094109

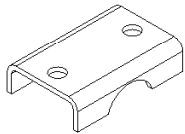

ITEM #11 556453270

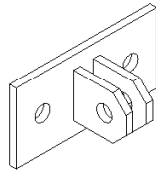

ITEM #13 556453273

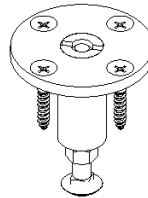

ITEM #19 FLOOR ANCHOR

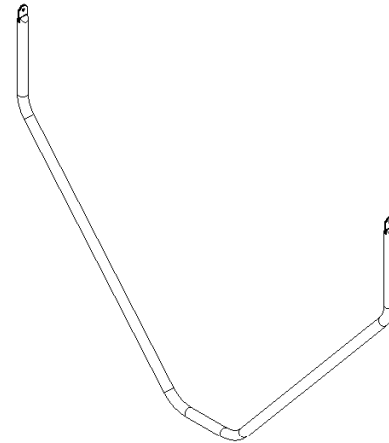

ITEM #12 556453272

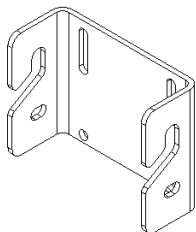

ITEM #14 556453576



ITEM#18 101851023

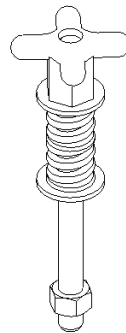

ITEM #20 3005-15-05

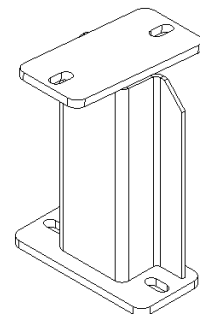

ITEM #30 556566299



INSTALLATION INSTRUCTIONS

Tools Required:

- *1/2", 9/16", 3/4", 15/16" combination wrench
 - *1/2", 9/16", 3/4" deep sockets with ratchet handle
 - *Allen wrench set
 - *Bubble type level
 - *12" Adjustable wrench with 1-1/8" capacity
 - #2 Phillips screw driver
 - Flat blade screw driver
 - Two plumb bobs with string
 - Tape measure
 - Hand drill
 - 3/4" and 1" Forstner or Spade Bit
 - Masking tape
 - Pencil
 - Anchor installation varies with floor type. See anchor installation instruction packaged with Floor Anchor, item 19, for additional tools.
- *These suggested tools can be stored in the toolbox on the portable unit for routine maintenance/adjustment or emergency goal or board change.

1. Unpack all parts and check for damage or missing items. Item numbers noted throughout these instructions refer to the parts listed in the parts check list on page 5 and pictured on page 6.

2. DO NOT remove Shipping Brace and/or Safety Pin until all added equipment has been installed on the boom.

⚠ WARNING

DO NOT REMOVE SHIPPING BRACE BEFORE INSTALLING BACKBOARD AND GOAL. REMOVING BRACE WITHOUT BACKBOARD INSTALLED COULD RESULT IN SERIOUS PERSONAL INJURY AND/OR DAMAGE TO UNIT.

126453732

The unit's spring assist has been adjusted at the factory to lift a specific weight which includes the boom, board, goal, padding, and any shot clock or signage that was specified at the time of the order. **The boom is shipped with a shipping brace to lock it into position until the board, goal, and any added equipment have been field installed.** Releasing the shipping brace and safety pin prematurely may cause the boom to lift uncontrollably, causing serious personal injury and/or damage to the unit. The charts below will show the correct springs and ballast to be used to counterbalance added boom equipment weight.

9716 SPRING CHART

CLOCK/BRKT WEIGHT (LBS)	556566277 QTY LARGE	556566278 QTY SMALL	BALLAST (lbs)
0	4	3	980
35	5	0	980
70	5	1	980
105	5	2	980
140	5	3	980
175	6	0	1450
210	6	1	1450
245	6	2	1450
280	6	3	1450
315	7	0	1450
350	7	1	1450
385	7	2	1450

9718 SPRING CHART

CLOCK/BRKT WEIGHT (LBS)	556566277 QTY LARGE	556566278 QTY SMALL	BALLAST (lbs)
0	5	0	1480
35	5	1	1480
70	5	2	1480
105	5	3	1480
140	6	0	1480
175	6	1	1480
210	6	2	1480
245	6	3	1480
280	7	0	1920
315	7	1	1920
350	7	2	1920
385	7	2	1920

BOARD AND GOAL ASSY

IMPORTANT NOTE:

Before proceeding to the next step, make sure at least three individuals are available to assist with the mounting of the backboard to the unit. A minimum of two, preferably three, individuals is required for safe assembly of the backboard to the unit.

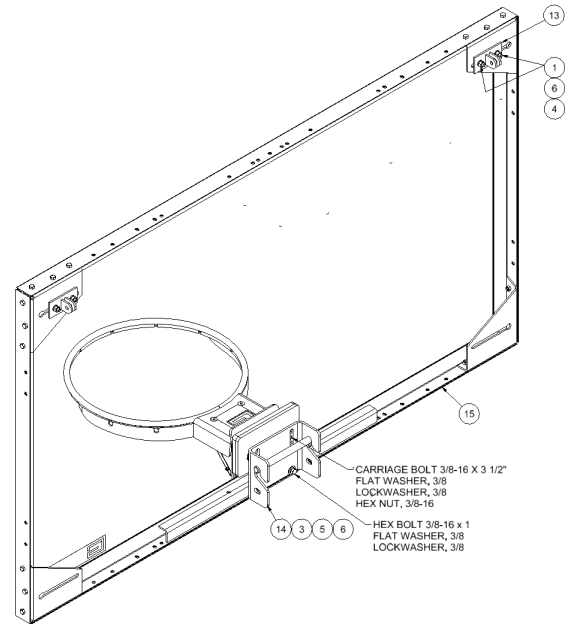

Figure 1

1. Position the Quick Change Backboard Bracket, item 14, to the back of the board and install a 3/8-16 x 1" bolt with flat washer and lock washer in the lower two holes of the mounting plate and into the two tapped insert holes of the LXP backboard, item 15, as shown in figure 2.

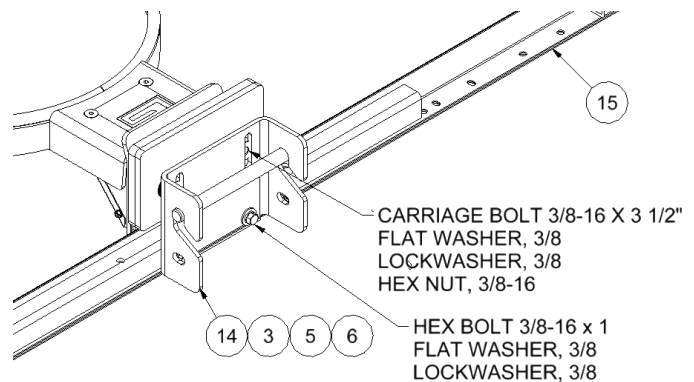

Figure 2

2. Using the hardware supplied with the goal, insert the two carriage bolts through the top goal mounting holes on the backboard and loosely install the nuts and washers on the back side of the board as shown in figure 2. Slide the goal over the carriage bolt heads and over the studs on the front of the board. Install the flat washer, lock washer and nuts on the studs and tighten to 9-11 ftlb [12-15 Nm]. Tighten the two top carriage bolts securely to 15-20 ftlb [20-27 Nm].

3. Attach the backboard brace brackets, item 13, to the top corners of the backboard as shown in figure 3. Use the 3/8-16 x 1" carriage bolts with lock washer and nuts for this assembly.

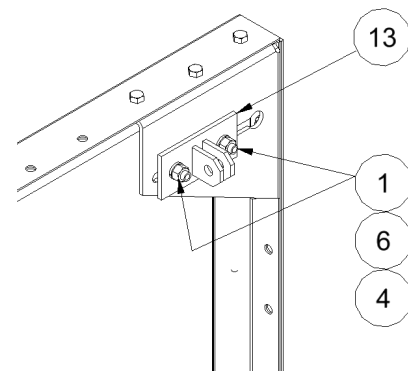

Figure 3

- Position the backboard and goal assembly with the slots of the Quick Change bracket onto the Quick Change Bracket Pins on the main boom as shown in figure 4,5, and 6. Slide the board assembly completely onto the pins and insert the Quick Change Locking Rod, item 8, through the slots and holes in the board and boom brackets. Secure the locking rod with the Hitch Pins, item 7.

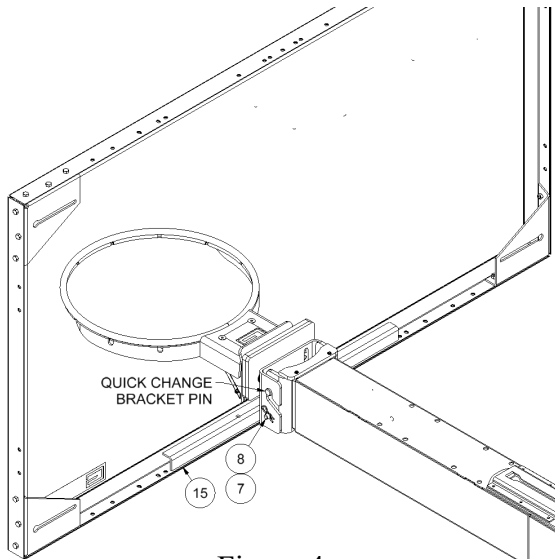

Figure 4

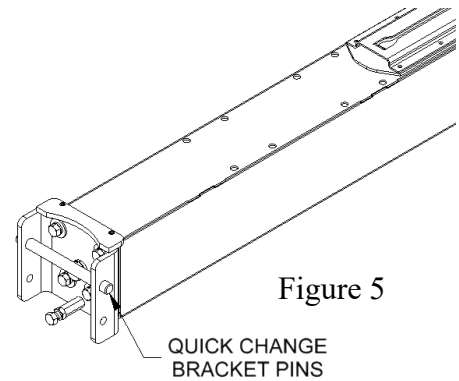

Figure 5

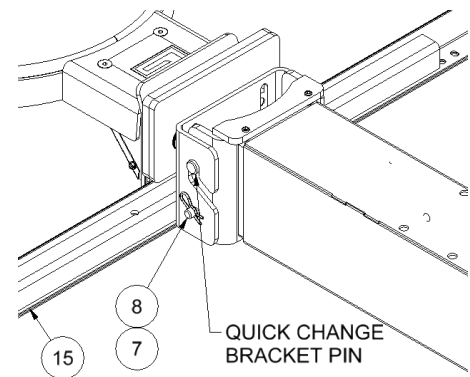

Figure 6

- Attach the Backboard Brace yoke, item 12, to the brackets installed in step 7 using the 3/8" Clevis Pins, item 9, and Hitch Pins, item 10, as shown in figure 7.

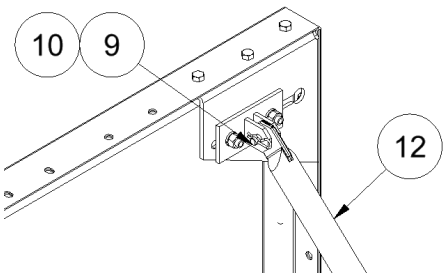

Figure 7

- Position the Board Brace Clamp, item 11, over the Board Brace yoke, item 12, and attachment plate on the boom as shown in figure 8. Secure the Clamp with (2) 3/8-16 x 2 1/2" carriage bolts, lock washers and nuts.

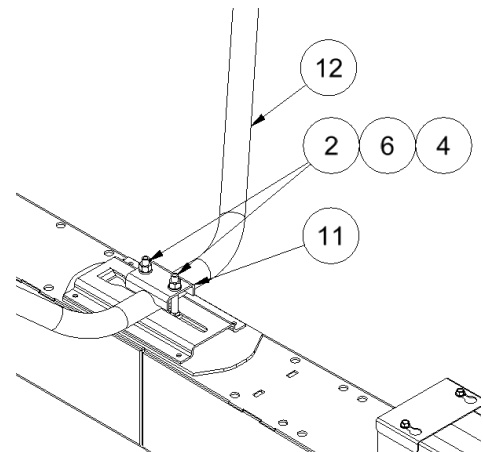

Figure 8

- With board and goal mounted, confirm that the Locking Pin on the Slide Latch Bar is in place as shown in figure 13. Then, remove the (4) 1/2-13 Hex Bolts to disassemble the Shipping Brace from the main boom and front upright. Store the Brace and Hardware in a location for future use when replacing backboards or transporting the unit.

⚠ WARNING

DO NOT REMOVE SHIPPING BRACE BEFORE INSTALLING BACKBOARD AND GOAL. REMOVING BRACE WITHOUT BACKBOARD INSTALLED COULD RESULT IN SERIOUS PERSONAL INJURY AND/OR DAMAGE TO UNIT.

126453732

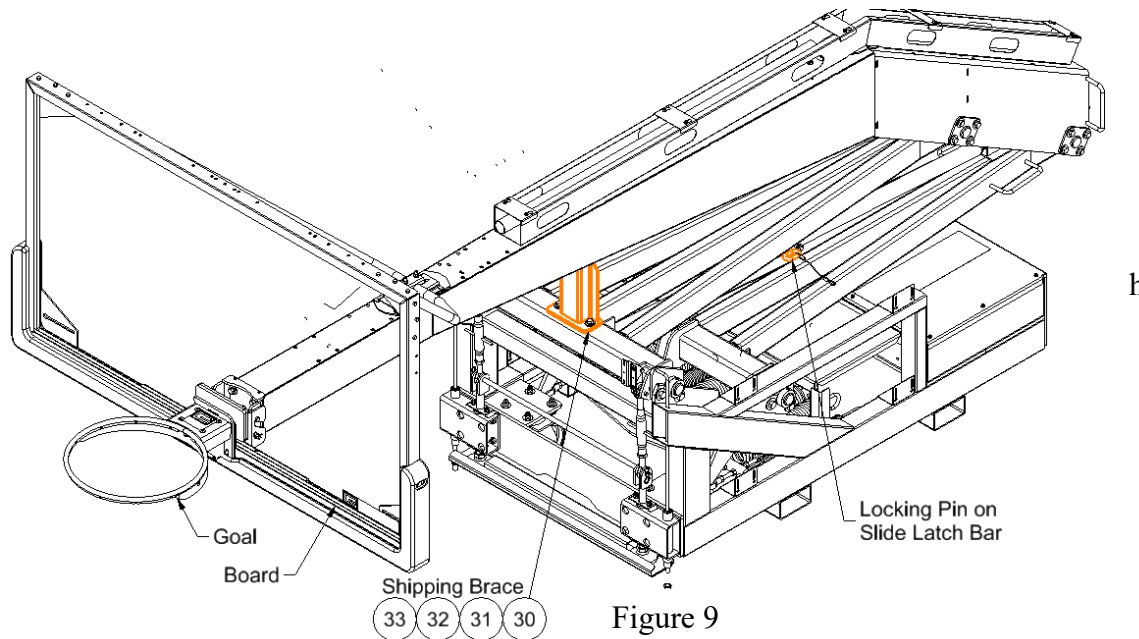

- The unit's spring assist has been adjusted at the factory to lift a specific weight which includes the boom, board, goal, padding, and any shot clock or signage that was specified at the time of the order. Attached these items if possible before proceeding to lift the unit into position. Should they not be available, an object of similar weight can be attached to the boom to make lifting more controllable.
- The first time the unit is lifted, have at least two strong people to assist in the lift until the correct spring pressure can be confirmed.

⚠ WARNING

SPRINGS ARE PRESET AT FACTORY. ADDITIONAL ADJUSTMENTS MUST BE DONE BY AUTHORIZED FACTORY PERSONNEL.

126453734

LOCATING AND ADJUSTING UNIT

- Using masking tape and pencil, Mark the location of the center of the court 4'-0" [1219 mm] from the inside edge of the court baseline (refer to figure 10). From this center mark, establish a mark 3'-0" [914 mm] to the left and another mark 3'-0" [914 mm] to the right. These marks will be used to align the face of bank to the court.

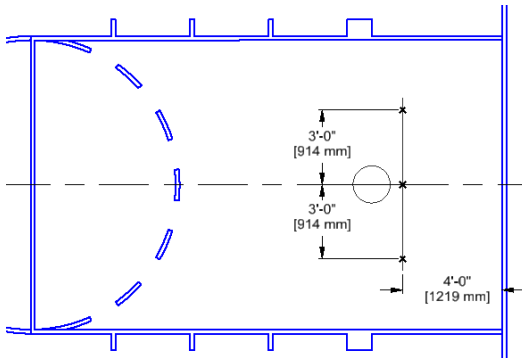

Figure 10

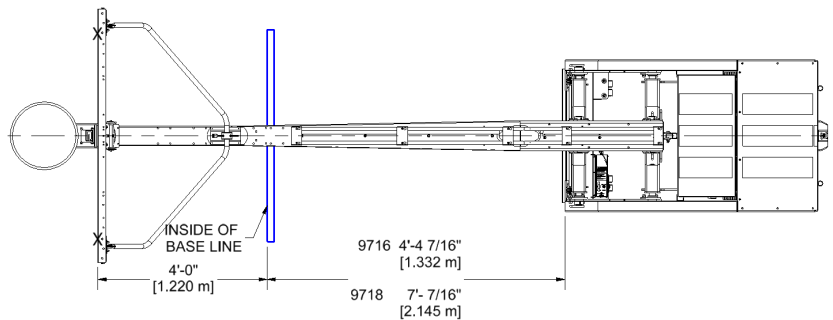

Figure 11

- Push the unit to the playing location on the court. The unit should be centered on the centerline of the court as shown in figure 11. From the inside edge of the court baseline to the front of the frame's Leveling Brackets, figure 12, should be about 4'-4 7/16" [1.332 m] for the model 9716 and 7'-0 7/16" [2.145 m] for the model 9718.

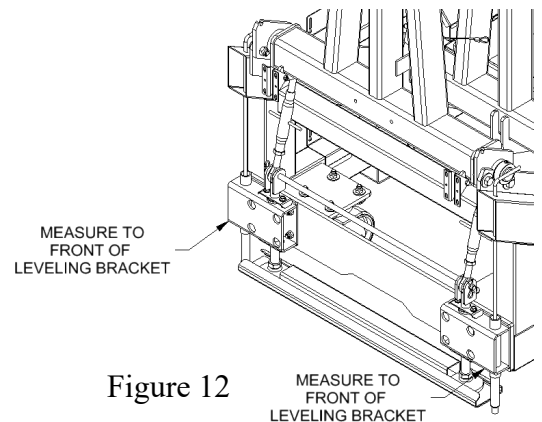

Figure 12

- Remove the Security Pin from the Sliding Latch Bar, (figure 13) and raise the boom to the 10' -0" playing position. Insert the safety pin into the Sliding Latch Bar behind the Front Upright (figure 14).

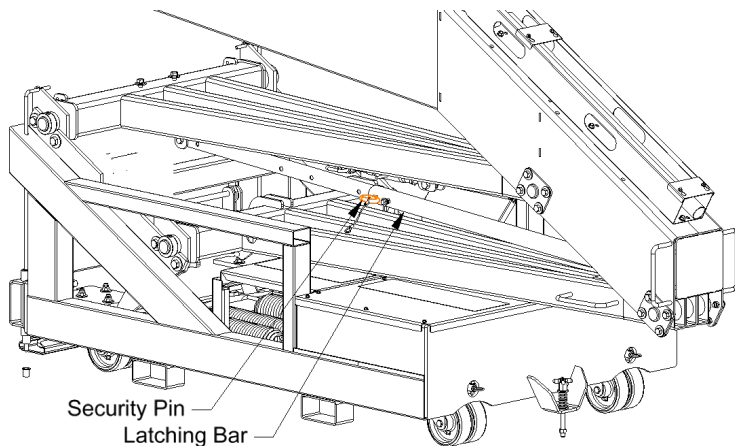

Figure 13 (storage position)

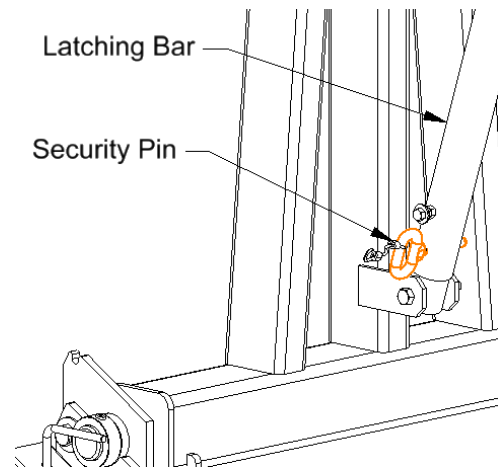

Figure 14 (play position)

- To level the backboard in the vertical plane, first loosen the two carriage bolts, item 2, at the Board Brace Clamp, item #15, on top of the boom as shown in figure 12. Using a $\frac{3}{4}$ " wrench, loosen the $\frac{1}{2}$ " Jam Nut and adjust the $\frac{1}{2}$ " Leveling Screw in the board mounting bracket as shown in figure 16 & 17 until the backboard is plumb. Tighten the locking nuts on the leveling bolt. Tighten the two carriage bolts at the Brace Clamp, item #11.

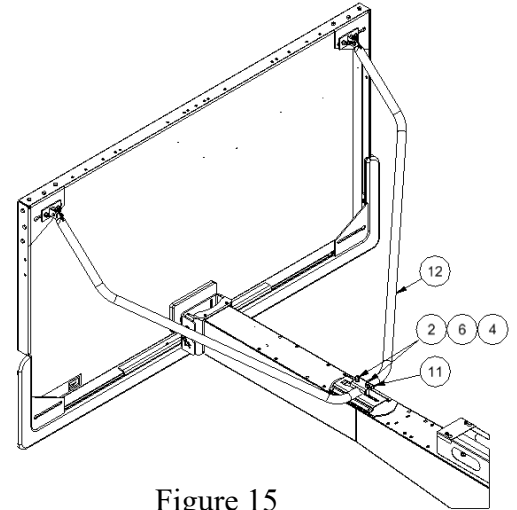

Figure 15

IMPORTANT NOTE:

- Failure to loosen board Brace Clamp, item 11, prior to leveling board may cause board glass to break during vertical level adjustment.
- Failure to adjust $\frac{1}{2}$ " Leveling Screw to support (touch) the back of the Board Bracket may cause board glass to break during heavy play.

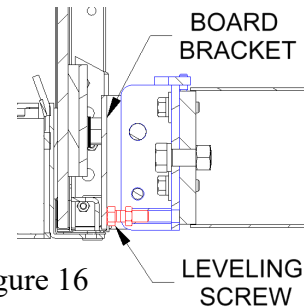

Figure 16

- To level the backboard in the horizontal plane, loosen the four $\frac{1}{2}$ " bolts and the one $\frac{3}{4}$ " bolt in the center of the Quick-Change Bracket attached to the boom. Refer to figure 17. Level the board horizontally using the Set Screws on top of the Boom Bracket and tighten all bolts securely.

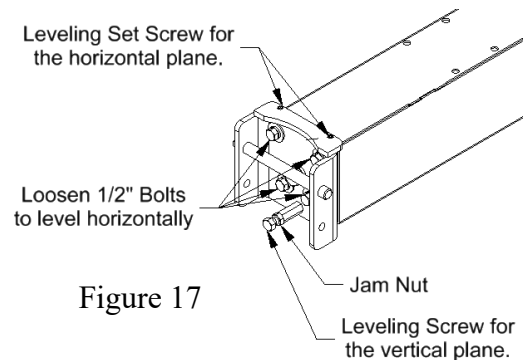

Figure 17

- Check the 10'-0" goal height at the top surface of the goal ring nearest the board. If adjustment is required, loosen the turnbuckle Jam Nuts and adjust the Leveling Turnbuckles, as shown in figure 18, to obtain 10'-0" measurement, making sure each Turnbuckle is raised or lowered evenly so that unit frame is level side to side. Adjustment is easier when unit is in the lowered position. Tighten the Jam Nut when Goal adjustment is completed.

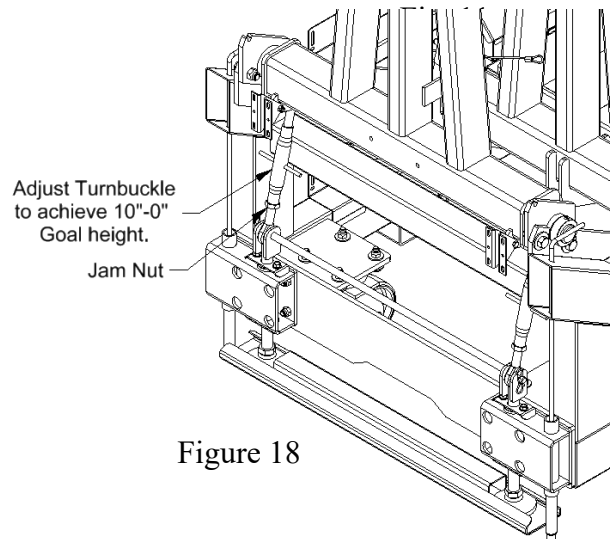
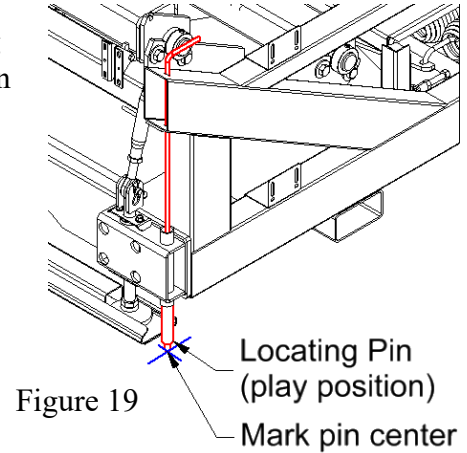
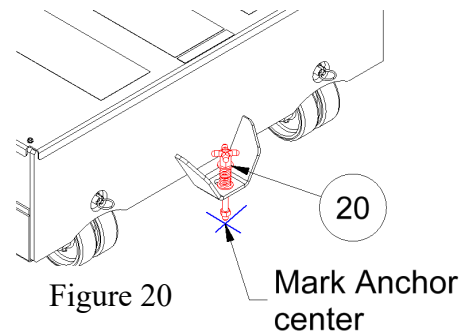

Figure 18

7. Attach plumb bobs to the front corners of the backboard. Plumb bobs should hang down from the corners to where they are almost touching the floor.
8. Check plumb bobs with marks that were located in step 1. If the plumb bobs do not line up exactly with the marks on the floor, adjust the location of the unit accordingly.
9. Once the unit is relocated and the plumb bobs are exactly on the marks located in step 1, recheck all dimensions to make sure the 10'-0" playing height is correct and the face of the backboard is 4'-0" in front of the court baseline.
10. Lower the Locator Pins to the "play position" touching the floor. Mark the pin centers on the floor as shown in figure 19.



11. Install the rear Tie Down Bolt, item 20, into the anchor hole on the back of the unit frame. Mark the center of the Anchor on the floor as shown in figure 20.



12. Lift the Locating Pins, remove the safety pin from the locking bar and lower the unit to the full down position and reinsert Safety Pin in the Locking Bar.
13. Push the unit away from the playing location on the floor to make room for drilling the floor for the Floor Bushings and rear Floor Anchor.
14. Refer the installation instructions for the rear Floor Anchor found in the package of the Floor Anchor (item 19) and install the insert into the floor. This insert is to be installed at the rear anchor location marked on the floor in step 11.

15. Using a 1" Forster or spade bit, drill a 1/8" deep counter-bore at the (2) Locator Pin locations marked on the floor in step 10. Using a 3/4" Forster or spade bit, drill through the rest of the floor (minimum of 1" deep) at the center of each of the counter-bores. See section view of finished hole in figure 21.

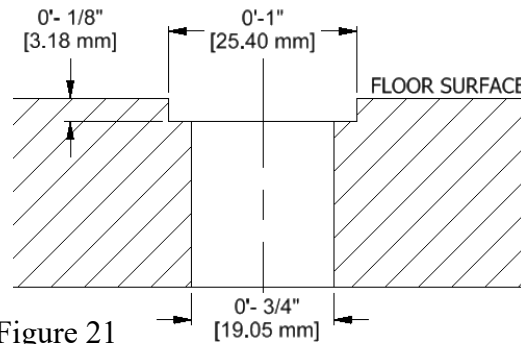

Figure 21

16. Insert the brass Locating Bushings, item 18, into the holes drilled in step 15. The top of Floor Bushing must be flush with floor surface.
17. Move the unit back into the playing position. Insert the Locator Pins into the floor inserts.
18. Install the rear anchor Tie Down Bolt, item 20, on the rear of the unit and secure the anchor bolt to the Floor Anchor insert, item 19.
19. Attach the backboard padding to the backboard using the instructions that are shipped with the board padding.
20. Raise the unit to the playing position and insert the safety pin into the sliding locking bar.

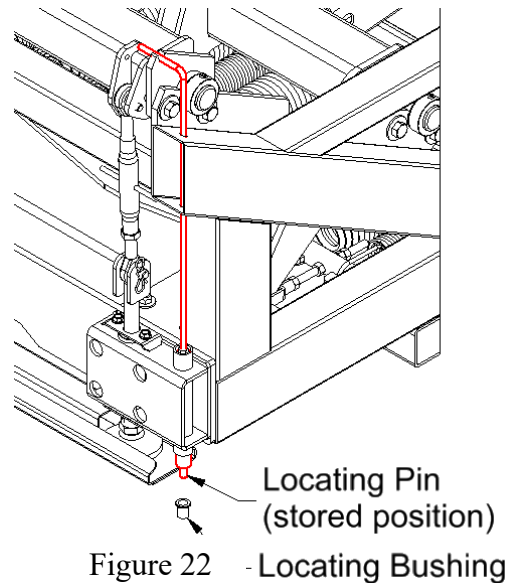

Figure 22 - Locating Bushing

IMPORANT NOTE:

Mark each unit to identify it for the specific location on the court as first located and leveled. Floor levelness and manufacturing tolerance may not allow for it to have correct position, goal height, or board levelness at other court locations.

PAD INSTALLATION

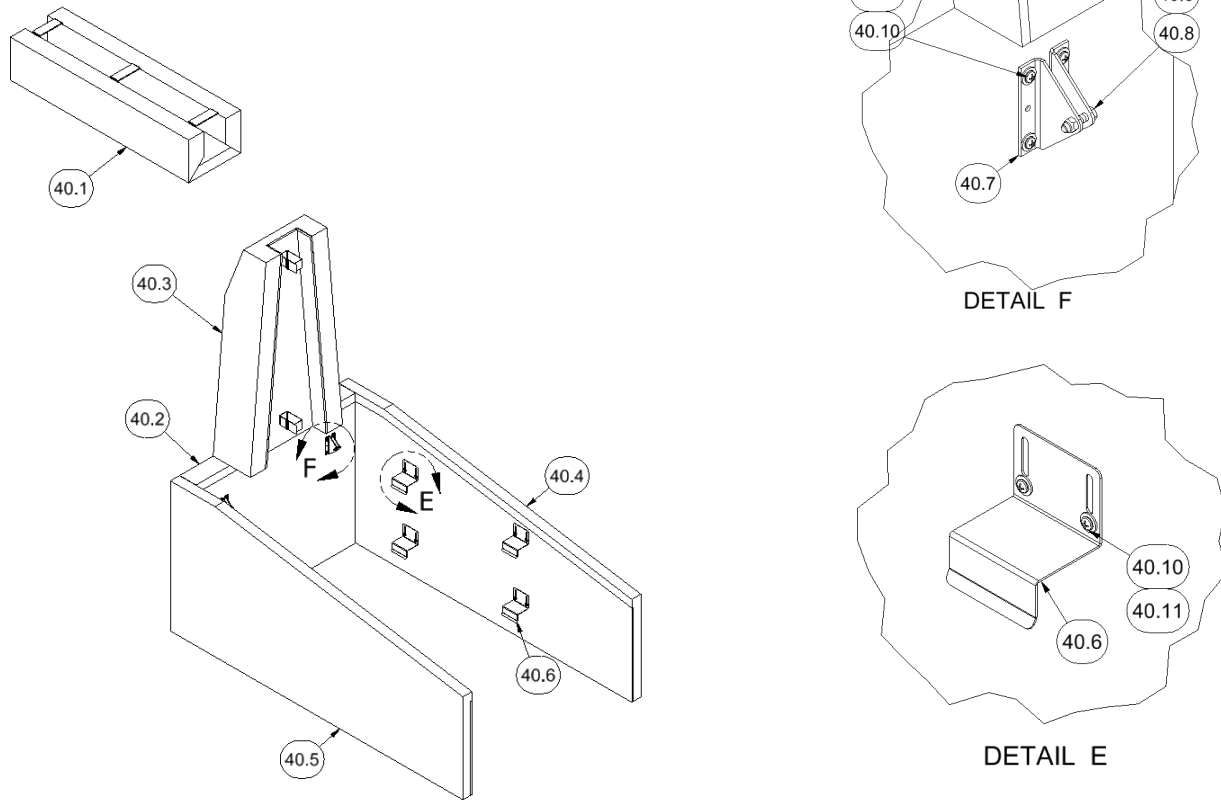

Figure 23

1. Install (2) Pad Hinge Brackets, item 40.7, to each side of the Front Lower Pad, item 40.2, using 1/4-20 Machine Screw and Flat Washer as shown in figure 23, detail F. The 1/4" Screws will engage the threaded holes in the back of the Pad. Adjust Screw in slot to be centered before tightening. Additional adjustment may be required to match the height of Side Pads in step 4.
2. Install the (4) Pad Clips, item 40.6, to the Side Pads, item 40.4 and 40.5 as shown in figure 23. detail E. The 1/4" Screws will engage the threaded holes in the back of the Pad.
3. Attach the Front Lower Pad, item 40.2, to the anchor on the Front Upright, bolting the Pad Hinge Bracket, item 40.7, using 5/16-18 Hex Bolt and Locknut as shown in figure 24. Locknut should be snug, but be loose enough to allow brackets to pivot freely.

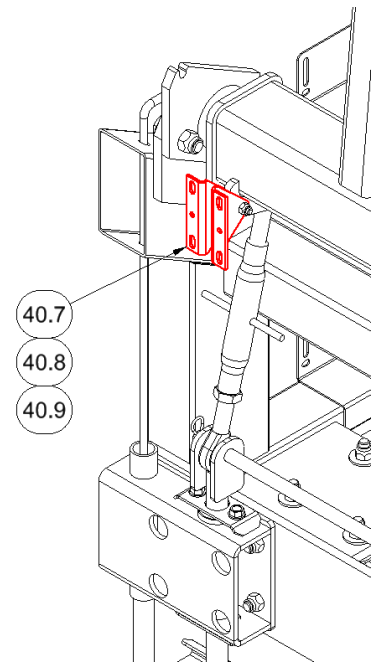

Figure 24

4. Install the Side Pads, item 40.4 and 40.5, by positioning its Pad Clips above the side frame rails and pushing the pad down. Pad Clip, item 40.6, will hook over both the top and bottom frame rails as shown in figure 25. The Pad Clip should bear on the top of each frame rail. The top of the Front Lower Pad, item 40.2, and the Side Pads should be even. Adjust the Front Pad vertically as required

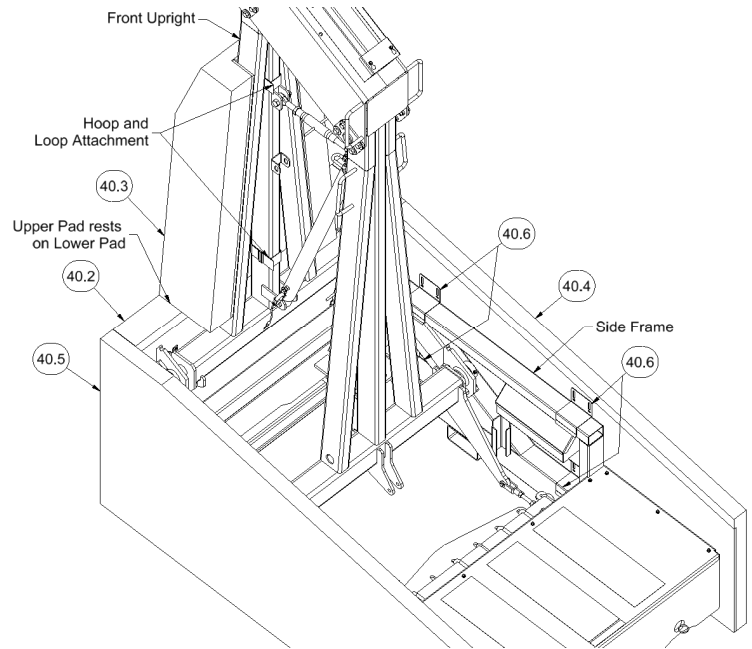

Figure 25

5. Install the Upright Pad, item 40.3, to the center post of the Front Upright using the hook and loop straps as shown in figure 25. The Upright Pad should touch the Lower Front Pad.

6. Install the Boom Pad, item 40.1, to the lower side of the Boom Weldment, using the hook and loop straps. The Boom Pad should be pushed tight to the Board Brackets as shown in figure 26.

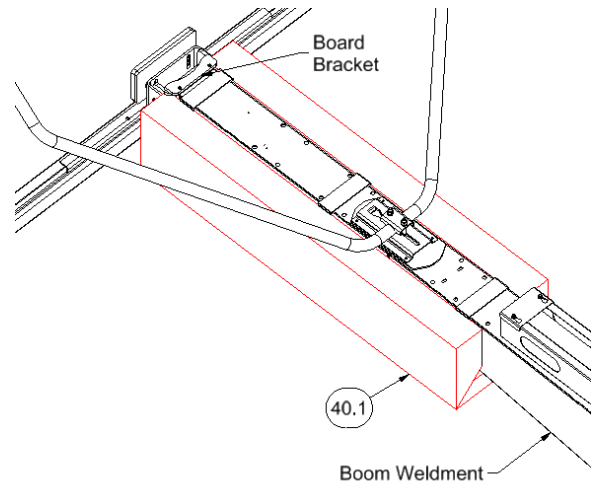

Figure 26

NOTE:

Factory Authorized installers should reference Troubleshooting Manual, 551756323-TS, for additional troubleshooting and adjusting information.

Operation

1. Before operating the unit, read all caution, warning, and information labels.
2. Position the unit on the floor.
 - a. Position the unit on the court so that the Locator Pins are directly over the Floor Bushings insert.
 - b. The rear wheels on the unit can be unlock to allow them to swivel, making positioning the rear of the unit easier. Pull the Caster Swivel Lock Pin out and rotate 90°, then push the rear of the unit to the side as required.
 - c. The rear Tiedown bolt is stored in the Tool Box. Install the rear Tie Down Bolt through the keyhole slot in the bracket at the rear of the frame. Screw it into the Floor Anchor insert.

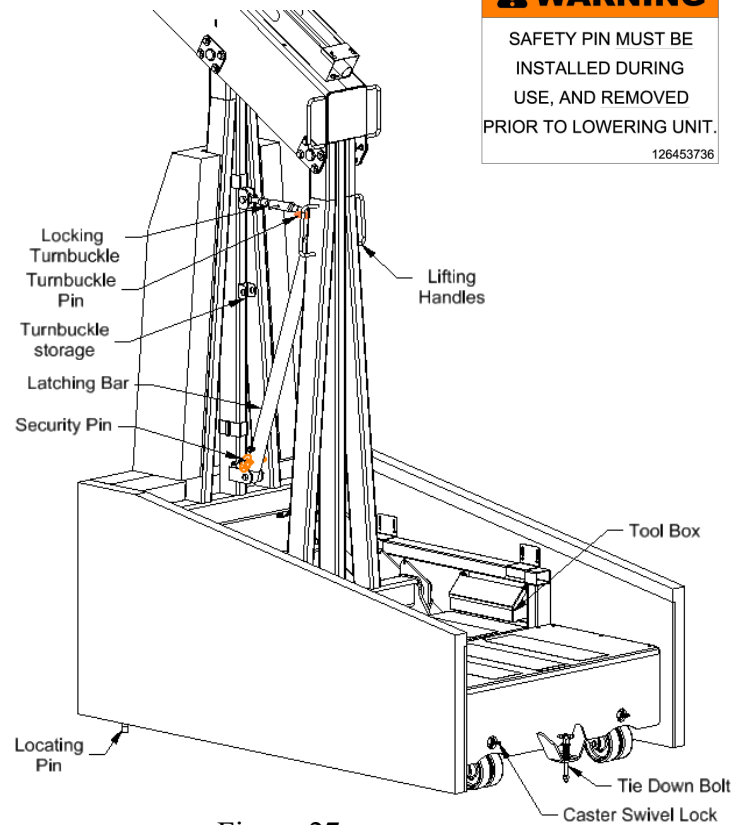

Figure 27

3. To raise the unit from the stored position;
 - a. Remove the Security Pin from the Latching Bar tube.
 - b. (Spring models only) Using the Lifting Handles on the Rear Upright, lift the upright and rotate to the full up position for a 10'-0" goal height. The unit can also be pinned at 8'-0" or 9'-0" goal height.
 - c. Install the Safety Pin into the slide tube Latching Bar as shown in figure 29.

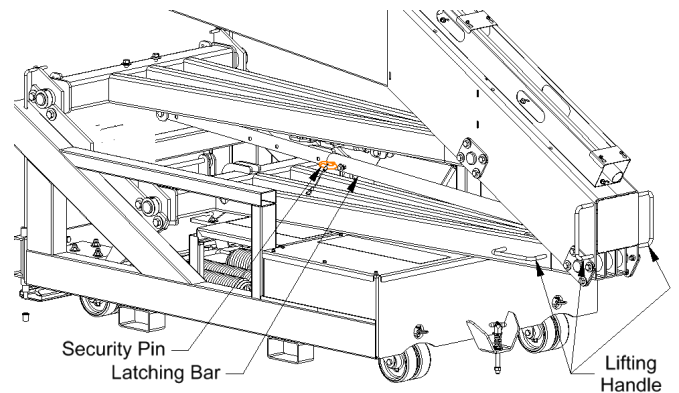

Figure 28

CAUTION

KEEP PERSONNEL AWAY FROM FRONT AND REAR OF UNIT WHILE RAISING OR LOWERING THE BACKBOARD

126453737

CAUTION

MOVING PARTS! KEEP HANDS, ARMS, BODY CLEAR DURING OPERATION

124252799

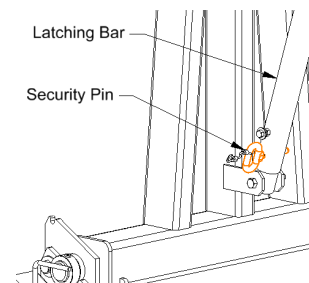

Figure 29

4. Install the Locking Turnbuckle by pinning it to the Rear Upright. Lightly tighten the turnbuckle to remove any movement in the Uprights.

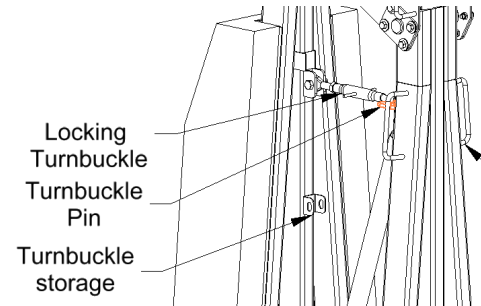

Figure 30

5. Check that the Front Leveling pad is on the floor and the Front Casters wheels clear the floor as shown in figure 31. Unit is ready to play.

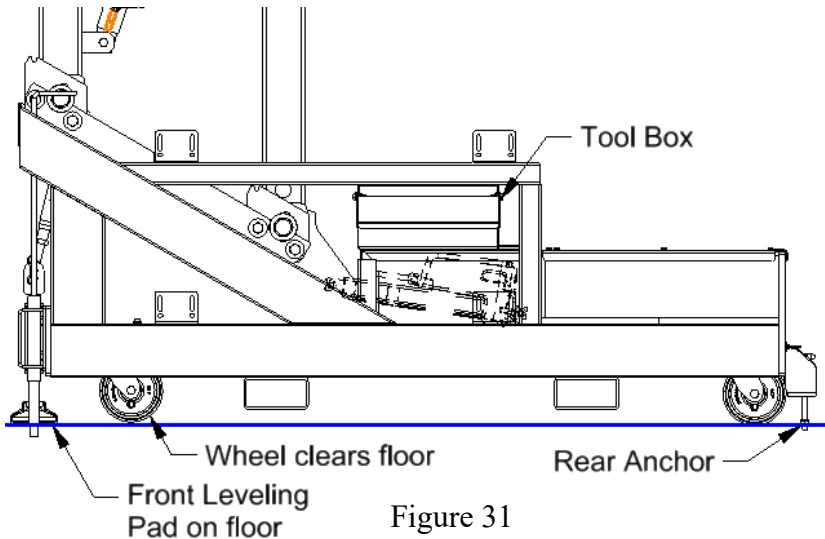

Figure 31

WARNING

REAR ANCHOR POINT MUST BE ATTACHED TO FLOOR ANCHOR AND FRONT LEVELING PADS MUST BE ON THE FLOOR WITH ALL WEIGHT OFF THE FRONT SWIVEL CASTERS BEFORE UNIT CAN BE USED FOR PLAY.

126453733

6. To lower the unit from the playing position;
 - a. Remove the Turnbuckle pin, loosen Locking Turnbuckle and swing it vertically down to the stored position and insert Pin as shown in figure 33.
 - b. Remove the Safety Pin from the slide tube Latching Bar.
 - c. (Spring models only) Using the handles on Rear Upright, pull the upright back and rotate it to the full down position, controlling the unit's rate of lowering until it rests on the Ballast Box Cover.
 - d. Install the Safety Pin into the slide tube Latching Bar hole.

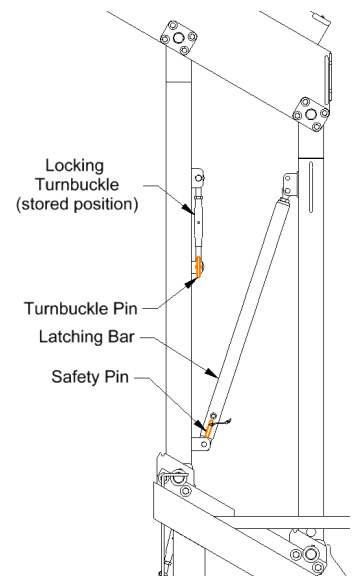

Figure 32

CAUTION

MOVING PARTS! KEEP HANDS, ARMS, BODY CLEAR DURING OPERATION

124252799

IMPORTANT NOTE:

Care should be taken to assist the unit as it lower to prevent it from falling uncontrolled. Failure to control the lowering could result in equipment damage or personnel injury.

7. If the unit is to be moved to storage,
 - a. Lift the Locating Pins and hook in the stored position as shown in figure 33.
 - b. Release the rear Tie Down Bolt. The Tie Down Bolt should be removed from the frame and stored in the Tool Box on the left-hand side of the unit, shown in figure 25 and 31.
 - c. If the rear Caster Swivel were unlocked, push unit forward enough to approximately align the casters with the frame, then pull the pin out by the ring and turn 90°. See figure 34. Caster locks will engage when rolled forward and casters are fully aligned.
 - d. Roll the unit to the storage facility. Moving the unit will require 1-2 persons pushing from the rear and a person steering the front of the unit by the goal.

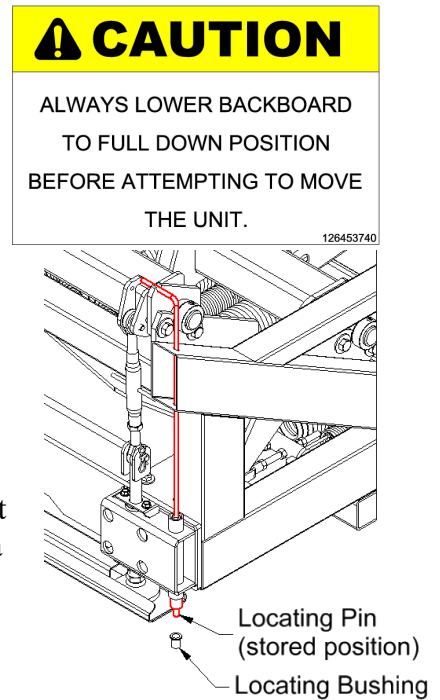

Figure 33

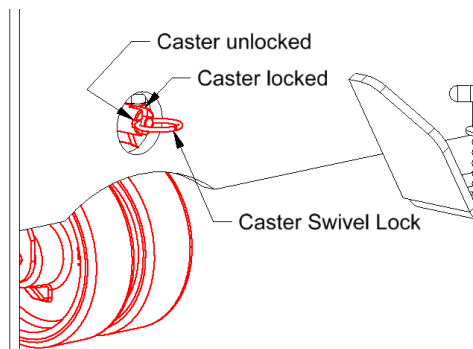

Figure 34

8. If the Board and Goal will be removed to transport, be sure to first install the Shipping Brace, item 30, using 1/2" hardware, item 31, 32, and 33 as shown in figure 35.

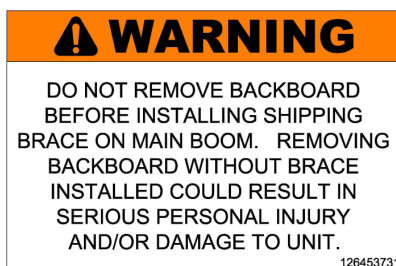

Figure 35

Electric Lift Operation (Model 9716E and 9718E)

WARNING

SAFETY PIN MUST BE INSTALLED DURING USE, AND REMOVED PRIOR TO LOWERING UNIT.
126453736



Remote Control Fob

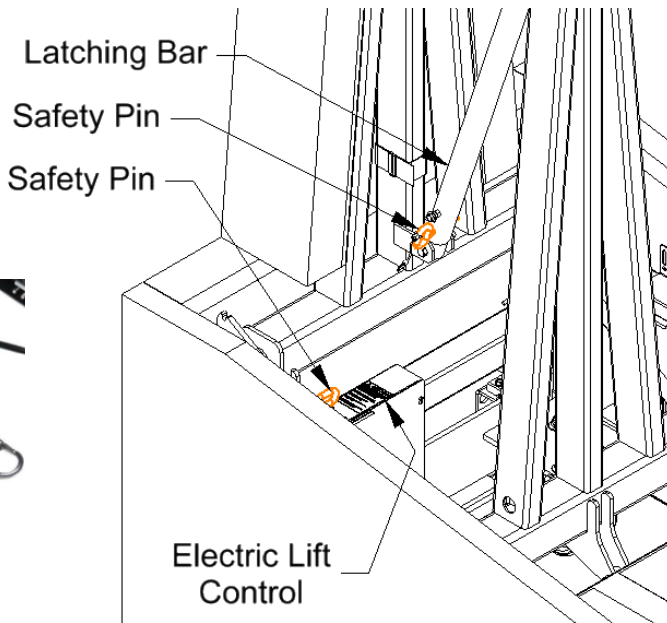

Figure 36

1. The E models are equipped with an electric lift system.
2. These models will require a power source of 120vac 60hz or 220vac 50hz. An 8' power cord is supplied. Requires 6.5a at 115vac or 3.5a at 220vac.
3. They can be operated in two modes as selected by the mode selector switch. Key or Remote mode. The Remote mode requires the supplied Remote Control Fob. Only one portable basketball unit should be operated at a time. Operator should have full view of the unit when operating.
4. Follow the operation instructions for the spring assist model starting on page 17. When it instructs you to lift or lower the unit, use the electric lift control feature as follows;
 1. Remove the Safety Pin and place it in the hole marked "LOCKING PIN" on the top of the Electric Lift Control to energize the control interlock as shown in figure 38.
 2. Select the mode of operation, Key or Remote and actuate the lift or lowering with the Key Switch or Remote Control Fob.
 3. When complete, return the Safety Pin to the Latching Bar as shown in figure 36.

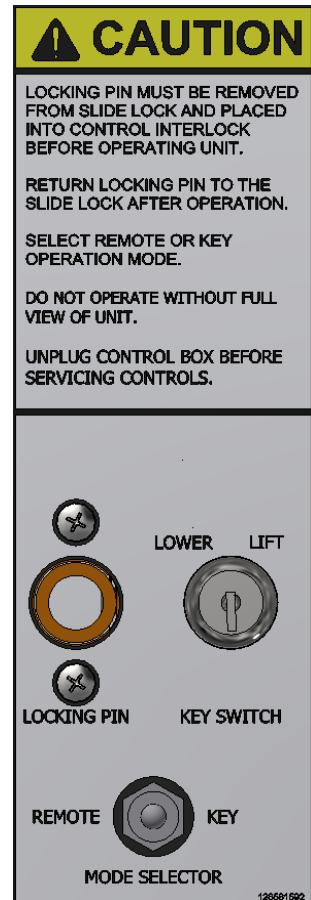

Figure 37

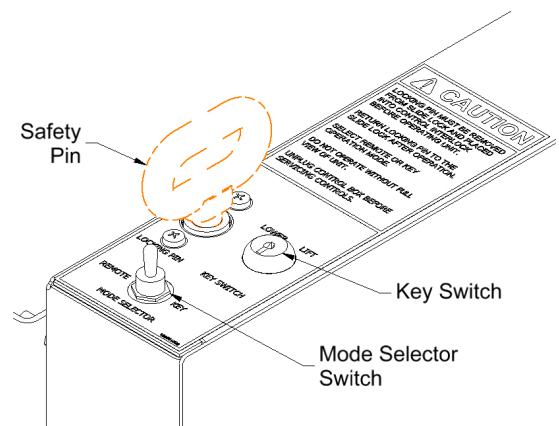
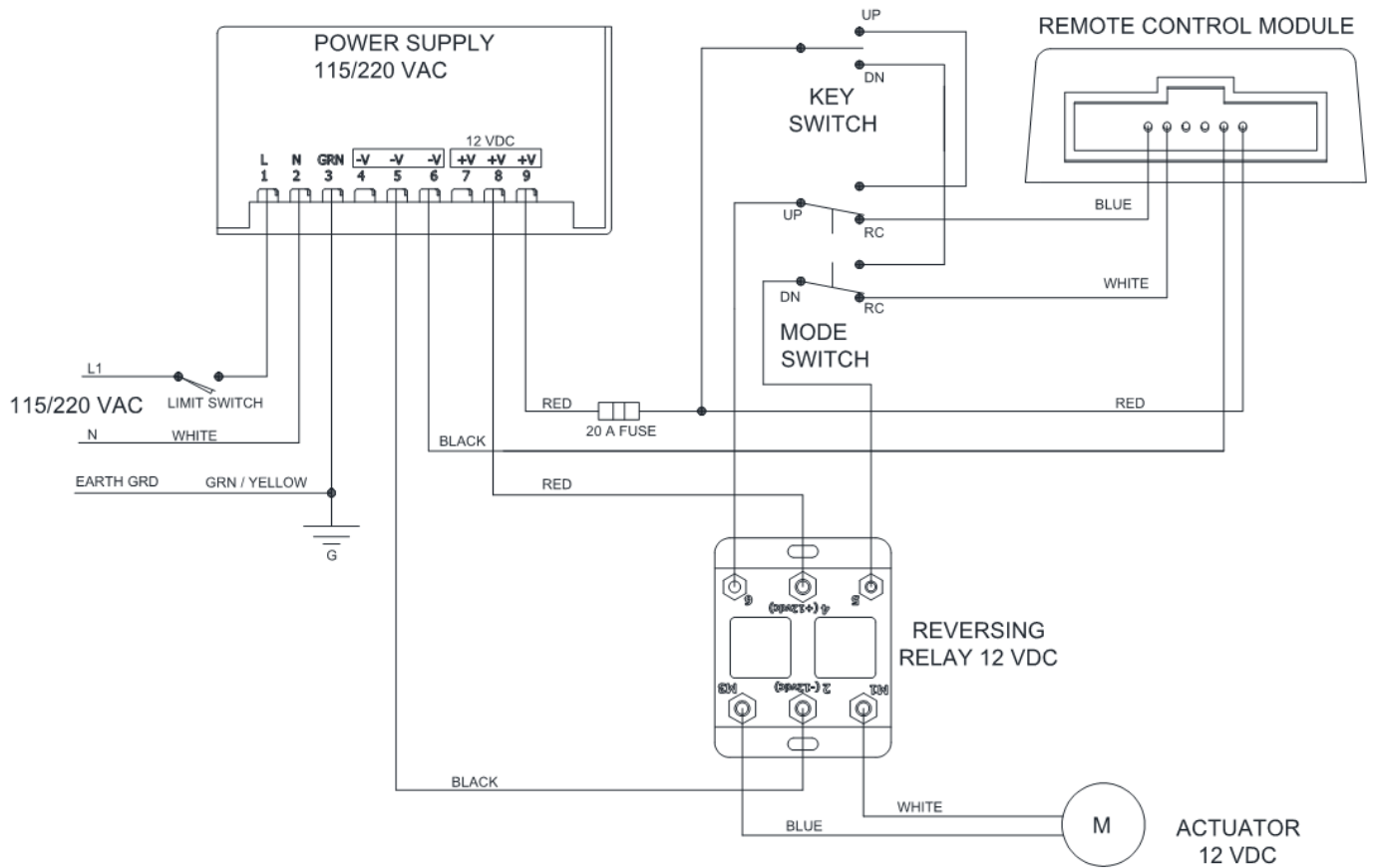

Figure 38

9716E and 9718E wiring diagram.



SET POWER SUPPLY INPUT VOLTAGE:

- Set switch on back of power supply for the appropriate input AC voltage. 115v or 220 v.
- Requires 6.5a at 115vac or 3.5a at 220vac.

Maintenance

1. General inspection of equipment when used should be performed to ensure no catastrophic failures have occurred during the course of use between yearly inspections.
2. It is recommended that yearly inspections be conducted to determine if any bolts or other hardware has become worn or loosened.
3. During yearly inspections,
 - Check all joints to make sure they are tight and secure.
 - Check all spring adjustment bolts to make sure they are tight and have not moved.
 - Check the board and goal mounting bolts to make sure they are tight.
 - Check the pads for wear.
 - Apply a small amount of grease on the slides of the leveling pad.
 - Any loose bolts or nuts should be tightened.
 - Replace any components that are missing or worn.

TROUBLESHOOTING

(Models 9716, 9718, 9716E, 9718E)

1. Unit is too heavy to lift or does not stay down when lowered down.

- A. The unit's spring assist has been adjusted at the factory to lift a specific weight which includes the boom, board, goal, padding, and any shot clock or signage that was specified at the time of the order. If additional weight has been added or removed, the spring tension or the number of springs will need to be adjusted. **CALL YOUR DEALER OR INSTALLER FOR ADJUSTMENT.**
- b. A correctly balanced unit will;
 - i. Stay in the down position when lowered and require a 20-40 lb lifting force to begin the lift.
 - ii. Be well balance in the 8-9 ft goal height range.
 - iii. Will stay at full 10' position when lifted and require a pulling force to begin the lowering process.
- c. Spring adjustment must be done only by **Authorized Factory Personnel.**

⚠ WARNING

SPRINGS ARE PRESET AT FACTORY. ADDITIONAL ADJUSTMENTS MUST BE DONE BY AUTHORIZED FACTORY PERSONNEL.

126453734

2. Leveling Pad does not touch floor or front wheels do not come off the floor when lifted.

- a. If Leveling Pad does not touch the floor, remove a Caster Shim from under the Front Casters Mount as shown in figure 4. Goal height adjustment should be readjusted.
- b. If Front Caster wheels come off the floor more than 1/4" [6 mm] add an additional 1/8" [3 mm] Caster Shim under the Front Caster Mount.

⚠ WARNING

REAR ANCHOR POINT MUST BE ATTACHED TO FLOOR ANCHOR AND FRONT LEVELING PADS MUST BE ON THE FLOOR WITH ALL WEIGHT OFF THE FRONT SWIVEL CASTERS BEFORE UNIT CAN BE USED FOR PLAY.

126453733

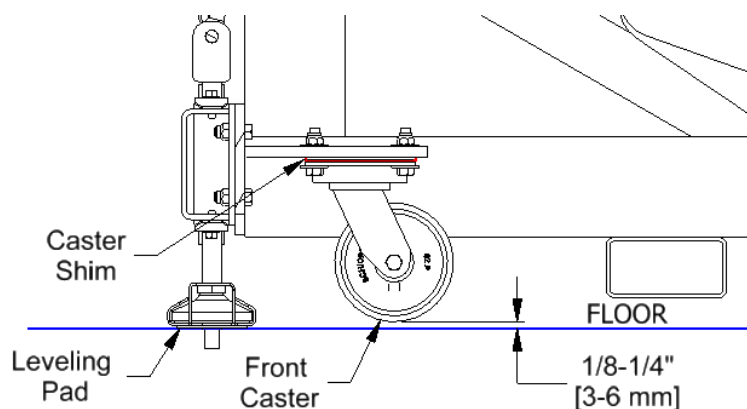

Figure 4



Gared Outer Limit Pro Portable Backstop



5. **Unit does not hold the correct goal height or board location when returned from storage.**
 - a. Be sure unit is returned to its original floor position. Mark each unit to identify it for the specific location on the court as first located and leveled during initial installation. Floor levelness and manufacturing tolerance may not allow for it to have correct position, goal height, or board levelness at other court locations.
 - b. Check the 10'-0" goal height at the top surface of the goal ring nearest the board. If adjustment is required, see LOCATING AND ADJUSTMENT of the installation section of this manual, page 12.

3. **The face of the Board is out of level vertically.**
 - a. See LOCATING AND ADJUSTMENT of the installation section in this manual, page 12.

4. **The top of the Board is out of level horizontally.**
 - a. See LOCATING AND ADJUSTMENT of the installation section in this manual, page 12.

5. Electric actuator does not run.

- a. Check to see if unit is plugged into power outlet.
- b. Check that power source to confirm that 115v or 220v is at outlet.
- c. Check that Safety Pin been removed from Latching Bar and inserted into the top of the Lift Control Box to activate the control interlock feature.
- d. Check that the desired mode been selected. Key or Remote.
- e. In Remote mode, the Remote Fob must be within 20 ft of the unit when operating.

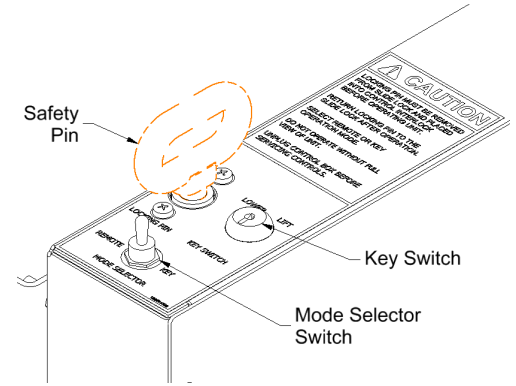

Figure 5

- f. If remote does not work, try changing to Key mode and using the Key Switch.
- d. Unit must be well balanced with springs. If spring balance has not been adjusted with added equipment, call dealer or installer to adjust spring assist balance.
- g. Should power not be available or in an emergency, the Actuator can be unpinned and unit manually lifted or lowered with only the spring assist.

- i. Remove Spring cover by lifting up the front of the cover and sliding off the pins in the ballast box.
- ii. Remove 1/2" Hex Bolt from front Actuator pivot.
- iii. Wire or tie the front of Actuator up so that it does not rub on springs during manual lifting or lowering.

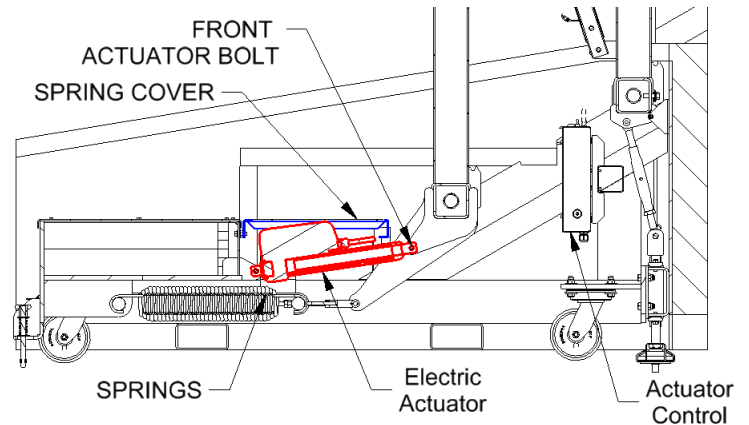

Figure 6



Gared Outer Limit Pro Portable Backstop





Gared Holdings, LLC

Performance Sports Systems
9200 E. 146th Street
Noblesville, IN 46060

800-848-8034
www.perfsports.com

Gared Sports
9200 E. 146th Street
Noblesville, IN 46060

800-325-2682
www.garedsports.com