

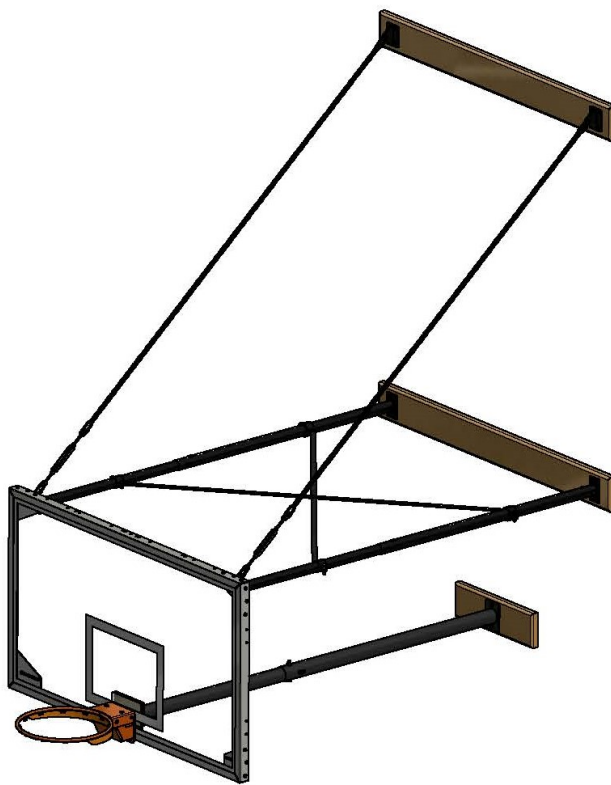

3 PT STATIONARY WALL MOUNT

Models: 2350



Operation and Maintenance Instructions

.....

Please read all instructions before attempting operation of these units

.....

SAVE THESE INSTRUCTIONS FOR FUTURE USE

PUBLICATION No.
501756251 Rev B

Issued
07-20-2021



Table of Contents

<u>Section</u>	<u>Page No.</u>
Introduction	1
Parts List	2
Installation Instructions	3-16
Unit Operation	17
Maintenance	18

Introduction

Thank you for your purchase of a Model 2350 3-point Stationary Wall Mount Backstop. To ensure that our equipment will provide years of use to you, we are including this operation, and maintenance guide. This guide will provide information on the proper operating procedures, and preventative maintenance of your gymnasium 3-point stationary wall mount backstop.

Do not make substitutions for any factory parts. If any parts are missing, do not substitute non-factory parts. Please contact your authorized dealer or manufacturer if any parts are missing or damaged.

It is recommended that an individual who has been properly trained perform operation of the 3-point stationary wall mount backstop. No one under the age of 18 should operate the backstop, unless properly supervised.

To prevent normal wear and tear from shortening the life of the backstop, preventative maintenance inspections and repairs should be performed at least once per year. If the backstop is subject to high or unusual usage, inspections should be scheduled to occur more frequently. If items are found to be nonconforming, replacements can be ordered from an authorized dealer. When contacting your dealer, please have information regarding the name of the project, and any applicable warranty information.

Note: Manufacturer assumes no responsibility for the building structure to support its products. It is the responsibility of the building designers to determine the correct structure size to support our products. We will provide your structural engineers with all required weight and loading information for the project in order for them to calculate the appropriate structure.



3 PT STATIONARY WALL MOUNT



2350 WALL MOUNT PARTS LIST

ITEM	PART NUMBER	DESCRIPTION										
			2030	2034	3040	3044	4060	4064	6090	6094	9120	9124
			QTY	QTY	QTY	QTY	QTY	QTY	QTY	QTY	QTY	QTY
1	504151591	WOOD PAD, 3.5" HC, 48" (NARROW)	1		1		1		1		1	
	504151590	WOOD PAD, 3.5" HC, 72" (WIDE)		1		1		1		1		1
2	504156224	WOOD PAD, TOP 48" (NARROW)	1		1		1		1		1	
	504156223	WOOD PAD, TOP 72" (WIDE)		1		1		1		1		1
3	504151589	WOOD PAD, 3PT WALL MOUNT	1	1	1	1	1	1	1	1	1	1
4	504151757	WALL BRKT, STAT. WALL MOUNT	2	2	2	2	2	2	2	2	2	2
5	504151627	PIPE WELDMNT,FU. OUTER, 2-3 FT (19.0")	2	2								
	504151628	PIPE WELDMNT,FU. OUTER,3-4 FT (24.5")			2	2						
	504151655	PIPE WELDMNT,FU. OUTER, 4-6 FT (36.25")					2	2				
	504151656	PIPE WELDMNT,FU. OUTER, 6-9 FT (55")							2	2		
	504151657	PIPE WELDMNT,FU. OUTER, 9-12 FT (78")									2	2
6	504151622	PIPE, FU. INNER, 2-3 FT (19.75")	2	2								
	504151623	PIPE, FU. INNER, 3-4 FT (26.25")			2	2						
	504151652	PIPE, FU. INNER, 4-6 FT (35.5")					2	2				
	504151653	PIPE, FU. INNER, 6-9 FT (58")							2	2		
	504151654	PIPE, FU. INNER, 9-12 FT (74")									2	2
7	504151637	EXT ARM, 3PT OUTER, 2-3 FT (18.75")	1	1								
	504151638	EXT ARM, 3PT OUTER, 3-4 FT (24.25")			1	1						
	504151639	EXT ARM, 3PT OUTER, 4-6 FT (36.50")					1	1				
	504151640	EXT ARM, 3PT OUTER, 6-9 FT (54.00")							1	1		
	504151641	EXT ARM, 3PT OUTER, 9-12 FT (78.00")									1	1
8	504151632	EXT ARM, 3PT INNER, 2-3 FT (19.50")	1	1								
	504151633	EXT ARM, 3PT INNER, 3-4 FT (26.00")			1	1						
	504151634	EXT ARM, 3PT INNER, 4-6 FT (37.75")					1	1				
	504151635	EXT ARM, 3PT INNER, 6-9 FT (56.75")							1	1		
	504151636	EXT ARM, 3PT INNER, 9-12 FT (74.00")									1	1
9	504151706	BUSHING, FOLDING UNITS .500 X .625	20	20	20	20	20	20	20	20	20	20
10	504156219	BRKT, CHAIN SHORT WOOD BUCK	4	4	4	4	4	4	4	4	4	4
11	504155264	BOARD BRKT, STATIONARY WALL MOUNT	4	4	4	4	4	4	4	4	4	4
12	1113-30-00	5/16" QUICK LINK	6	6	6	6	6	6	6	6	6	6
13	1045-30-00	CHAIN, 5/0 STRAIGHT COIL - ZINC	5 ft	5 ft	6 ft	6 ft	10 ft	10 ft	17 ft	17 ft	24 ft	24 ft
14	7011-11-00	3/8" TURNBUCKLE	2	2	2	2	2	2	2	2	2	2
15	504151670	STRAP BRACING 48"					2				4	
	404151671	STRAP BRACING 60"							2			
	504151672	STRAP BRACING 69"						2				4
	504151673	STRAP BRACING 78"								2		
16	1093-02-08	#93 STRAP CLAMP, 2.38"					2	2	2	2	6	6
17	1092-02-08	#92 STRAP CLAMP, 1.9"					2	2	2	2	2	2
18	501651854	SPACER BUSHING, 2-1/8 X 2-3/8					4	4	4	4	12	12
19	501-6-16-16	BOLT, CARRIAGE 3/8-16 UNC X 1	8	8	8	8	8	8	8	8	8	8
20	501-6-16-32	BOLT, CARRIAGE 3/8-16 UNC X 2	16	16	16	16	16	16	16	16	16	16
21	501-6-16-44	BOLT, CARRIAGE 3/8-16 UNC X 2.75	2	2	2	2	2	2	2	2	2	2
22	101651056	WASHER, 3/8 SQ X 1.38 OD X .120	16	16	16	16	16	16	16	16	16	16
23	502-6-16-20	HEX BOLT, 3/8-16 UNC X 1.25	8	8	8	8	8	8	8	8	8	8
24	502-6-16-40	HEX BOLT, 3/8-16 UNC X 2.5	4	4	4	4	4	4	4	4	4	4
25	502-8-13-56	HEX BOLT, 1/2-13 UNC X 3.5	8	8	8	8	8	8	8	8	8	8
26	502-8-13-64	HEX BOLT, 1/2-13 UNC X 4	1	1	1	1	1	1	1	1	1	1
27	548-6-16	HEX NUT, SERRATED FLANGE 3/8-16	20	20	20	20	24	24	24	24	28	28
28	545-8-13	HEX NUT, NYLON LOCK 1/2-13	8	8	8	8	8	8	8	8	8	8
29	512-6-16-6	SET SCREW, FLAT POINT 3/8-16 UNC X 0.375	4	4	4	4	4	4	4	4	4	4
30	226-6-16-20Z	SCREW, MACH FL HD SLOT 3/8-16 UNC X 1.25	2	2	2	2	2	2	2	2	2	2
31	561-6	FLAT WASHER 3/8	8	8	8	8	8	8	8	8	8	8
32	501756251	MANUAL, 2300 STAT. WALL MOUNT	1	1	1	1	1	1	1	1	1	1

FOR AAG MODELS 2350-xxxxA

40	5743	MTG KIT, AAG TO 3 PT WM 63" (WIDE)		1		1		1		1		1
	5744	MTG KIT, AAG TO 3 PT WM 35" (NARROW)	1		1		1		1		1	
41	4404	MTG KIT, 63X36 RECT BOARD TO AAG		1		1		1		1		1
	4405	MTG KIT, 35X20 FAN TO AAG	1		1		1		1		1	

Optional Accessories sold separately:

1131 Manual Height Adjuster

1171 Electric Height Adjuster



3 PT STATIONARY WALL MOUNT



Locate, identify, and count all parts before starting the installation to ensure that all are correct and correspond to the packing list/production drawings. If any parts are missing or damaged, **DO NOT SUBSTITUTE**. Contact your authorized dealer or the manufacturer for assistance in obtaining the correct part.

Also review production drawings to ensure that building conditions have not changed since the initial field check. Verify overall height and width noted on drawings.

INSTALLATION PREPARATION

Before installing a wall mounted backstop unit, it is imperative the structural integrity of the wall has been evaluated and approved by an architect or structural engineer for the loads that will be imparted to the wall by the backstop.

⚠ WARNING
<p>Unit must only be installed on walls approved for its rated loads by architect or structural engineer.</p> <p>Failure to attach to approved wall structure can cause unit to fall resulting in serious injury or death.</p>

⚠ WARNING
<p>Use only anchors rated for minimum of 5 times wall loads listed for the unit.</p> <p>Incorrect anchors can fail causing unit to fall resulting in damage and serious injury or death.</p>

The best wall construction for use with wall mounted backstops is concrete masonry units (CMU) or solid concrete panel. Further, through bolting of the wood pads to the wall is the recommended method of attachment. However, when through bolting is not possible, the anchors used must be of a type that will provide at least 5 times the load listed for the anchor point of the unit. All anchors, including through bolts, must be minimum 1/2" diameter and at least SAE Grade 5 equivalent material.

Mounting the wall mounted backstop to a wood or metal stud structure is not recommended or approved by the manufacturer unless the structure has been reinforced as specifically designed by an architect or structural engineer for the desired wall mounted unit.

Please refer to the load charts on the following page for information concerning the specific unit being installed.

NOTICE
<p>The loads listed for the upper wood pad and chain anchors are based on the wood pad located on the same surface as the lower wood pads. If the upper wood pad is not located on the same vertical surface as the lower wood pads, contact the factory for the correct loads.</p>

UNIT LOADING INFORMATION

2350 WALL MOUNT, W/O HEIGHT ADJUSTER, MODEL	2350-4060 (fan mount)	2350-4064	2350-6090 (fan mount)	2350-6094	2350-9120 (fan mount)	2350-9124
FACE OF BANK (FOB) (ft-in)	4'-0" to 6'-0"	4'-0" to 6'-0"	6'-0" to 9'-0"	6'-0" to 9'-0"	9'-0" to 12'-0"	9'-0" to 12'-0"
DIM 'B' (in)	20	36	20	36	20	36
DIM 'C' (in)	FOB minus 18"	FOB minus 18"	FOB minus 18"	FOB minus 18"	FOB minus 18"	FOB minus 18"
DIM 'D' (in)	35	63	35	63	35	63
Unit Weight (lbs)	266.2	266.2	291.1	291.1	324.1	324.1
STATIC & DYNAMIC						
Force A (lbs)	452	452	419	419	410	410
Force B (lbs)	83	247	50	214	41	205
Force C (lbs)	868	540	868	540	868	540
Force D (lbs)	356	356	362	362	369	369
Force E (lbs)	9	9	13	13	17	17
Force F (lbs)	18	18	25	25	34	34

2350 WALL MOUNT, W/ HEIGHT ADJUSTER, MODEL	2350-4060A (fan mount)	2350-4064A	2350-6090A (fan mount)	2350-6094A	2350-9120A (fan mount)	2350-9124A
FACE OF BANK (FOB) (ft-in)	4'-8" to 6'-8"	4'-8" to 6'-8"	6'-8" to 9'-8"	6'-8" to 9'-8"	9'-8" to 12'-8"	9'-8" to 12'-8"
DIM 'B' (in)	20	36	20	36	20	36
DIM 'C' (in)	FOB minus 18"	FOB minus 18"	FOB minus 18"	FOB minus 18"	FOB minus 18"	FOB minus 18"
DIM 'D' (in)	35	63	35	63	35	63
Unit Weight (lbs)	396.6	396.6	421.5	421.5	454.5	454.5
STATIC & DYNAMIC						
Force A (lbs)	464	464	455	455	454	454
Force B (lbs)	-37	186	-46	177	-47	176
Force C (lbs)	1132	687	1132	687	1132	687
Force D (lbs)	423	423	429	429	435	435
Force E (lbs)	8	8	12	12	17	17
Force F (lbs)	17	17	23	23	34	34

FOB = FACE OF BANK/ BACKBOARD

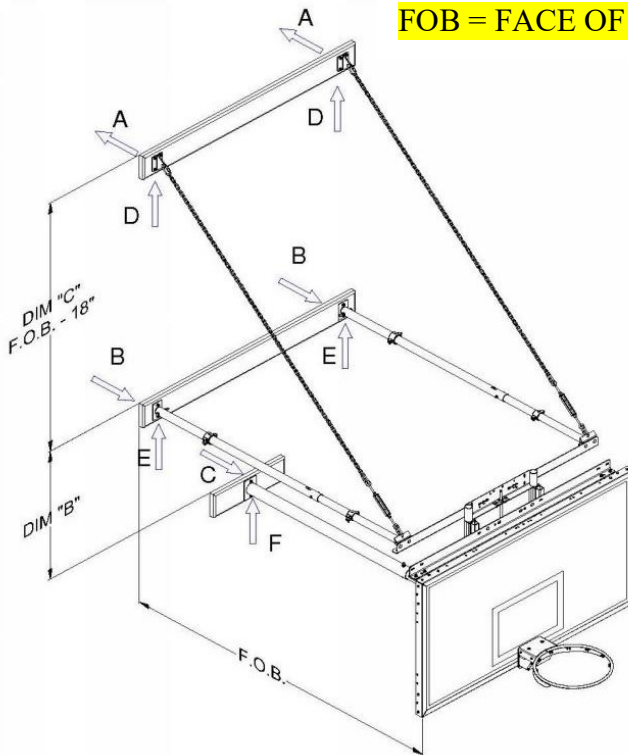

Dynamic loads include a 500 lb dunk load applied on front of goal at 15° from vertical.

Contact manufacturer for loads on custom units or when Dim "C" varies from the FOB minus 18" standard.



3 PT STATIONARY WALL MOUNT



TOOLS REQUIRED

- Plumb Bob or Laser Level
- Electric Drill
- Drill bits – 7/16”, 9/16”, 5/8”
- Hammer
- Wrenches – 1/2", 9/16”, 11/16, and 3/4"
- Ratchet Wrenches with 1/2", 9/16”, 11/16, and 3/4" sockets
- File
- 4’ Level
- 25’ Tape measure
- Duct Tape
- Block of wood (for tapping)
- Broom
- Shop-Vac
- Utility Knife
- Extra rope or chain
- Torque Wrench
- Scissor Lift or Scaffolding

RECOMMENDED BOLT TORQUE				
Bolt Size	Wrench Size	In-Lbs	Ft-Lbs	Nm
1/4"	7/16"	66 to 90	5.5 to 7.5	8 to 10
5/16"	1/2"	132 to 180	11 to 15	15 to 20
3/8"	9/16"	234 to 318	19.5 to 26.5	27 to 36
7/16"	11/16"		31 to 42.5	43 to 58
1/2"	3/4"		47 to 65	64 to 88
9/16"	7/8"		68 to 90	93 to 122
5/8"	15/16"		94 to 130	128 to 176
3/4"	1-1/8"		166 to 230	226 to 312
7/8"	1-5/16"		269 to 372	365 to 504
1"	1-1/2"		402 to 566	546 to 767

INSTALLATION

Installation instructions below are general in nature. Your exact installation needs to follow the parts and any specific instruction included in your specific project's production drawings.

1. Before installing the wood pads on the wall, you must first preassemble the hinge brackets and chain brackets onto the wood bucks.

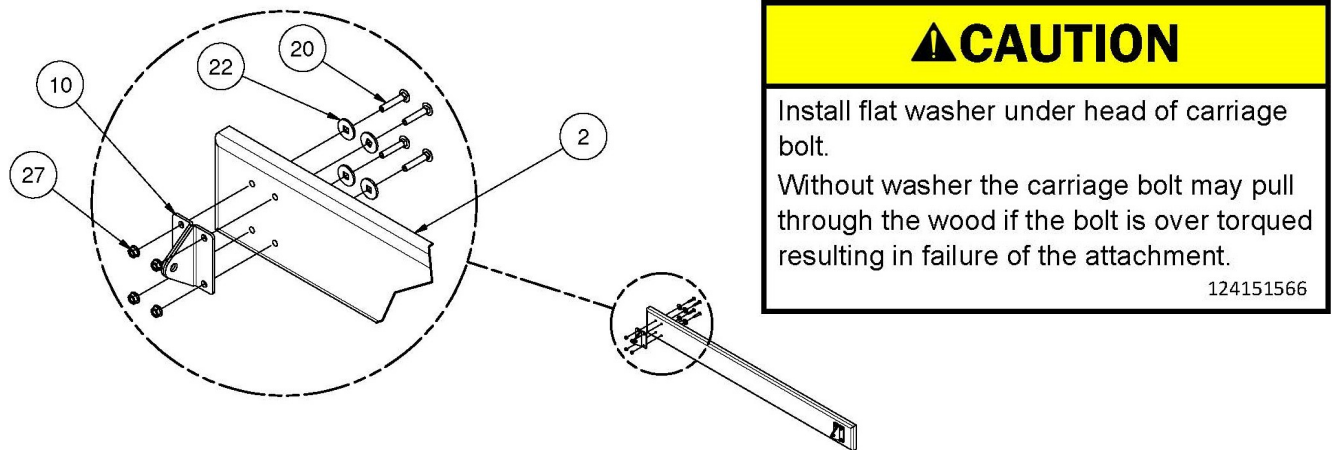

2. Install the chain support brackets onto the top wood pad using the hardware shown in the above illustration.

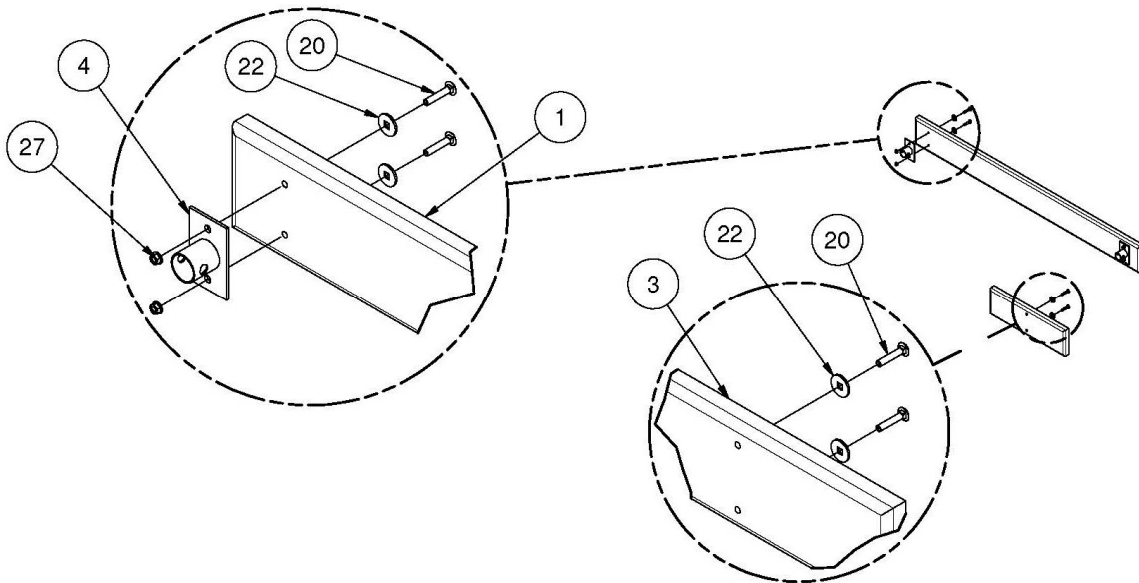

3. Install the extension tube wall brackets on the center pad using the hardware shown in the above illustrations.
4. Install the carriage bolts and washers through the back of the lower wood pad. As shown in the above illustrations.
5. The wood pads are now ready to be installed onto the wall.

WOOD PAD LOCATIONS

Always refer to specific dimensions outlined in the production drawings shipped for the specific project. Dimensions of the specific project may vary from the dimensions outlined below.

UNITS INSTALLED WITHOUT HEIGHT ADJUSTER			
	DIM "A"	DIM "B"	DIM "D"
Rectangular			
LXP 4200	9'-9 5/8" (2.99M)	2'-11 1/2" (0.90M)	63" [1.60 m]
AFRG 42	9'-10 1/16" (3.00M)	2'-11" (0.89M)	63" [1.60 m]
1442B	9'-8 5/16" (2.95M)	2'-11 3/8" (0.90M)	63" [1.60 m]
AFRG48	9'-8 9/16" (2.96M)	3'-0" (0.91M)	63" [1.60 m]
RG	9'-8 9/16" (2.96M)	3'-0" (0.91M)	63" [1.60 m]
Fan			
1301B	9'-8 11/16" (2.96M)	2'-1" (0.64M)	35" [0.81 m]
1342B	9'-8 11/16" (2.96M)	2'-1" (0.64M)	35" [0.89 m]
1750B	9'-8 3/16" (2.95M)	1'-9 1/4" (0.54M)	35" [0.89 m]
1245T	9'-8 5/16" (2.95M)	1'-9 1/2" (0.55M)	35" [0.89 m]
1272B	9'-8 3/16" (2.95M)	2'-0 1/4" (0.62M)	35" [0.89 m]

UNITS INSTALLED WITH HEIGHT ADJUSTER			
	DIM "A"	DIM "B"	DIM "D"
Rectangular			
LXP 4200	10'-0 15/16" (3.07M)	3'-4 1/8" (1.02M)	63" [1.60 m]
AFRG 42	10'-1 1/2" (3.09M)	3'-4 1/8" (1.02M)	63" [1.60 m]
1442B	10'-0 15/16" (3.07M)	3'-4 1/8" (1.02M)	63" [1.60 m]
AFRG48	9'-11 9/16" (3.04M)	3'-4 1/8" (1.02M)	63" [1.60 m]
RG	9'-11 9/16" (3.04M)	3'-4 1/8" (1.02M)	63" [1.60 m]
Fan			
1301B	9'-11 15/16" (3.05M)	3'-4 1/8" (1.02M)	35" [0.89 m]
1342B	9'-11 15/16" (3.05M)	3'-4 1/8" (1.02M)	35" [0.89 m]
1750B	9'-11 1/2" (3.04M)	3'-4 1/8" (1.02M)	35" [0.89 m]
1245T	9'-11 1/2" (3.04M)	3'-4 1/8" (1.02M)	35" [0.89 m]
1272B	9'-11 1/2" (3.04M)	3'-4 1/8" (1.02M)	35" [0.89 m]

ALL UNITS	
DIM "C"	FOB minus 18"

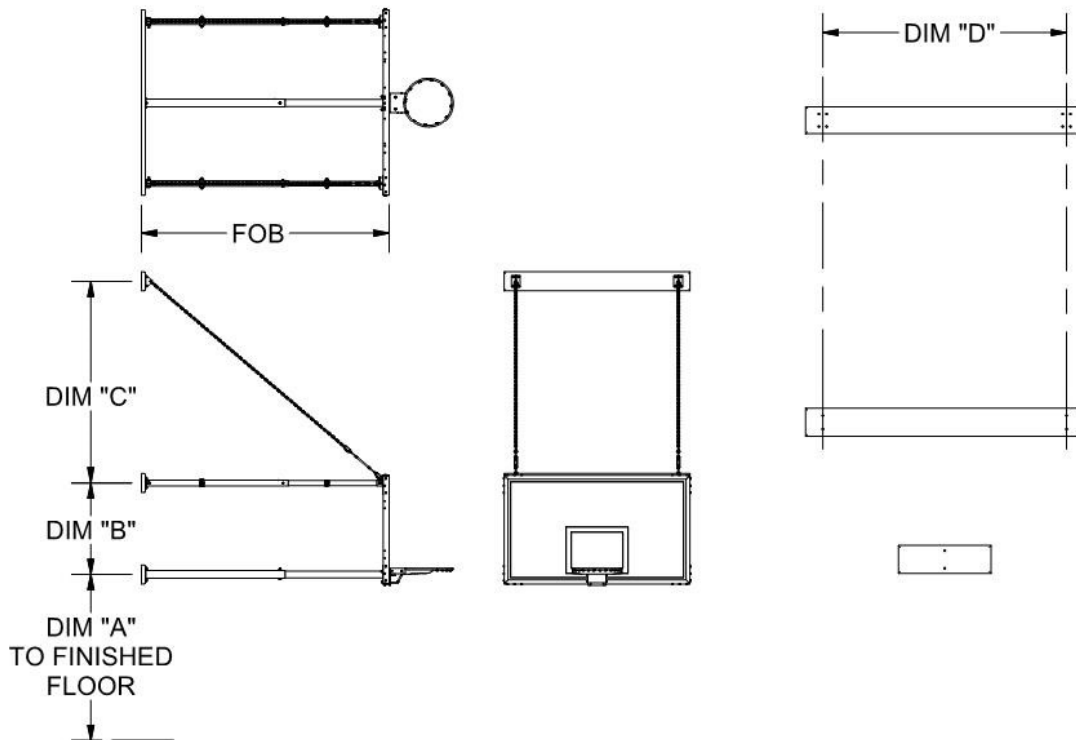

Note: The upper wood pad with the chain anchors should be mounted in the same plane as the two frame mounting wood pads. The load information for the upper chain anchor is based on the wood pad located in the same plane. Contact the manufacturer for correct reaction loads if there is a wall condition that does not allow the wood pads for the chain anchors to be in the same plane as the frame pads.

WOOD PAD WALL ATTACHMENT

When attaching the wood pads to the wall, it is important to place the anchors in a location that will not reduce the strength of the wood. Anchors should be ½” diameter and the holes in the wood pads should be no larger than 9/16” in diameter. The centerline of the holes should not be closer than 2” from the edge or end of the wood pads.

Refer to the illustration below for the recommended locations of the anchors on the wood pads.

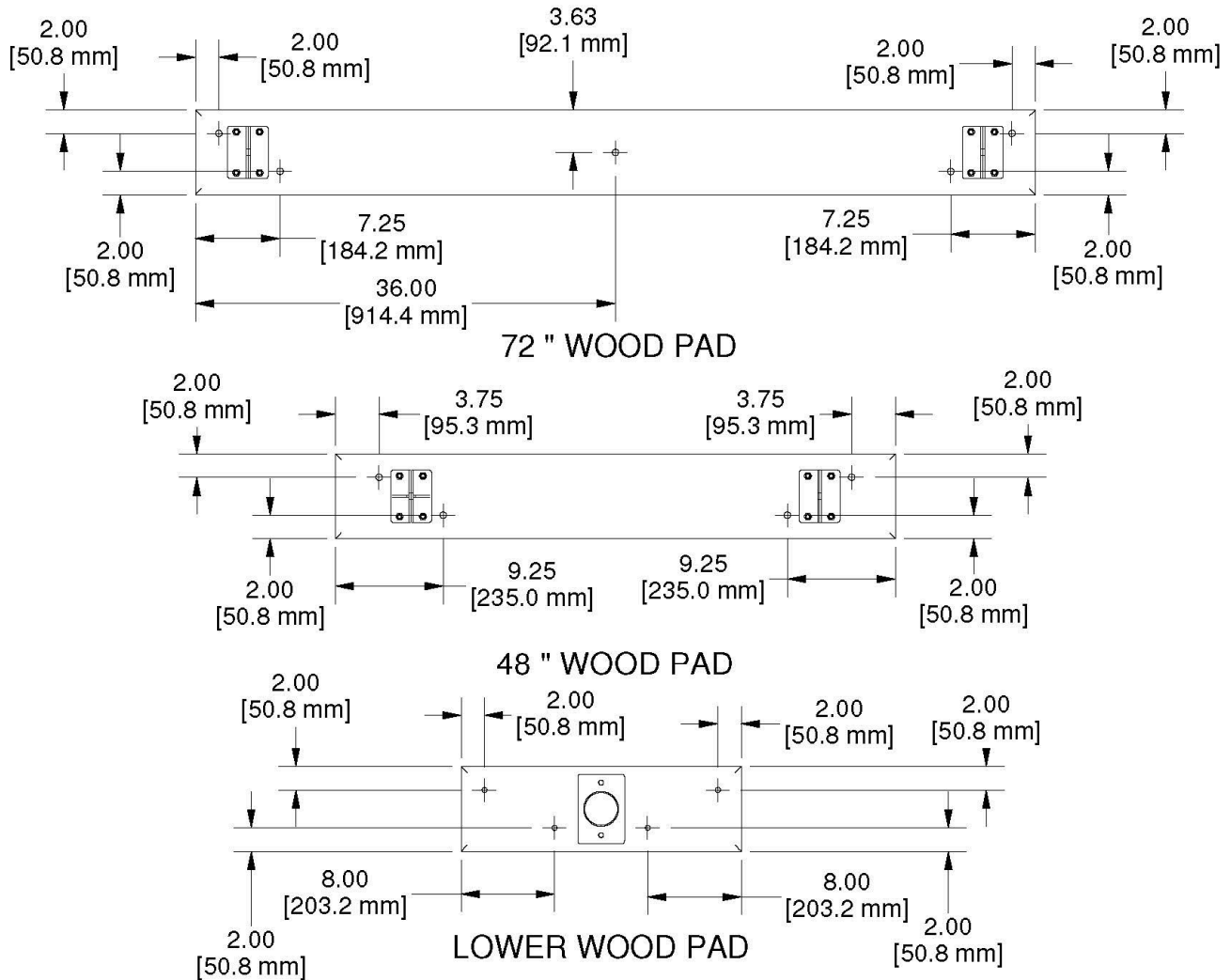

⚠ WARNING

Centerline of anchor holes shall be no closer than 2.0" to the edge or end of wood buck.

Wood buck may fail causing unit to fall resulting in damage to unit and/or serious injury or death.

⚠ WARNING

Use only anchors rated for minimum of 5 times wall loads listed for the unit.

Incorrect anchors can fail causing unit to fall resulting in damage and serious injury or death.

Install the upper outer pipe weldments to the wall brackets on the center wood pad. Slide the outer pipe over the bracket tube and insert the flange bushings (Item 6) into both sides of the pipe. Make sure the bushings go through both outer pipe and bracket tube.

Once the bushings have been installed into the pipe, install the 1/2 x 3 1/2" hex bolt through the bushings and install the 1/2" nylon lock nut. Tighten the nut until there is no play between the bushings and the pipe.

Do not overtighten the nut as this may crimp the tube and damage the wall bracket.

Install the lower outer pipe extension onto the carriage bolts of the lower wood pad. Secure with the 3/8" whiz-lock nuts.

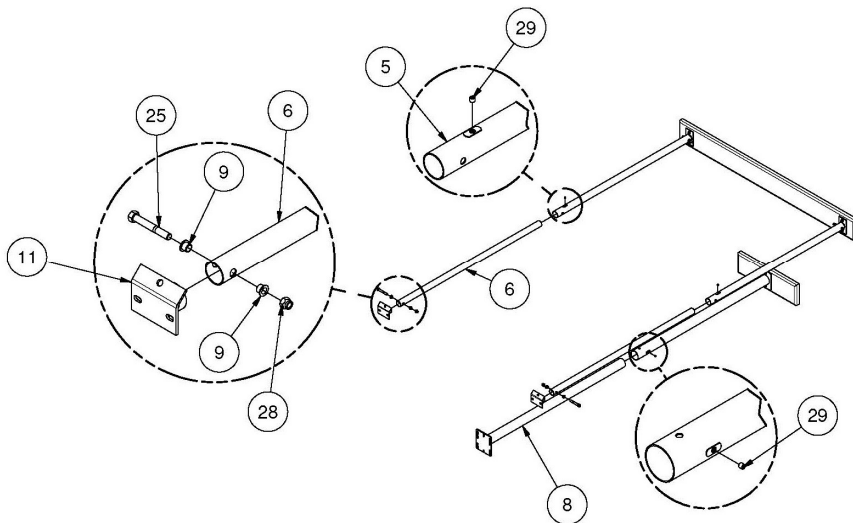
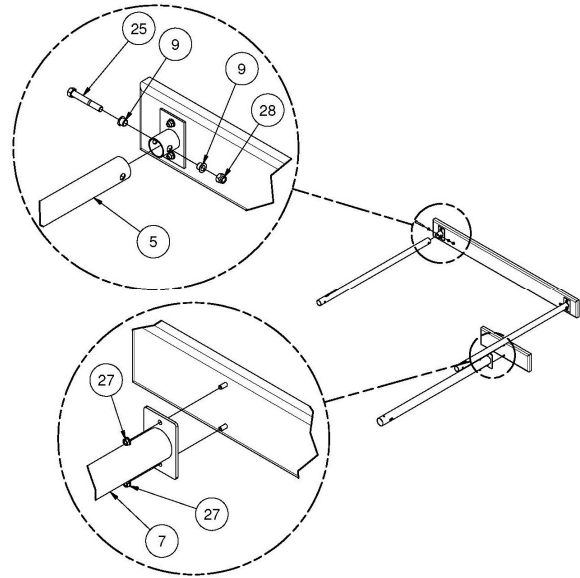

Slide the top inner extension pipes into the top outer extension pipes.

Install the board mtg. bracket over the inner extension tube. Align the holes in the bracket with the holes in the tube and insert the flange bushings (Item 6) into both sides of the pipe. Make sure the bushings go through both bracket and inner tube.

Once the bushings have been installed into the pipe, install the

1/2 x 3 1/2" hex bolt through the bushings and install the 1/2" nylon lock nut. Tighten the nut until there is no play between the bushings and the pipe.

Do not overtighten the nut as this may crimp the tube and damage the board bracket.

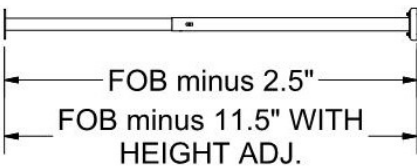

Slide the extension tube until the distance from the wall to the face of the board bracket is equal to the FOB minus 2.5" or FOB minus 11.5" when a height adjuster is to be used. Install the set screw (Item 29) into the outer extension tube and lightly tighten the set screw.

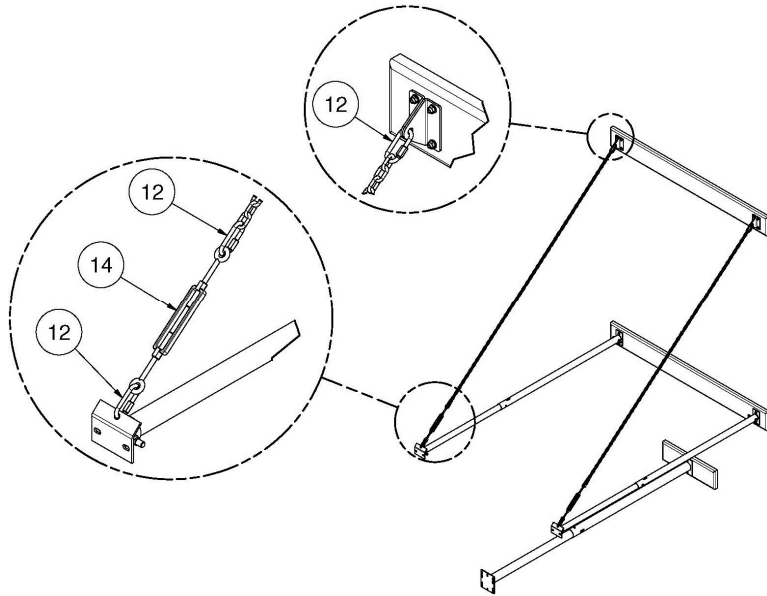

Install the 50 chains on each side of the unit. Attach the chain to the upper chain supports with the 5/16" quick links. Make sure the links are fully closed and tightened.

▲CAUTION
Fully close and tighten Quick Link. Loose or open Quick Link may fail and cause serious damage to unit. 124151565

Attach the turnbuckle to the chain attach plate with a 5/16" quick link. Attach the loose end of the chain to the turnbuckle using a quick link.

Tighten the turn buckle by hand putting

only a light tension on the chain. **DO NOT fully tighten at this time.** The turnbuckles will need to be readjusted later.

Once both chains are installed, the top extension tubes should be approximately level.

Install the cross bracing onto the upper extension arms. Refer to the illustration for the correct attachment method.

Note: The 3/8 x 1-1/4" and, 3/8 x 2" carriage bolts, and the 3/8" whiz-lock nuts are supplied with items 16 and 17 and are not listed in the parts list.

DO NOT fully tighten these clamp bolts at this time as it may be necessary to reposition them after the board and goal are installed and the FOB is set.

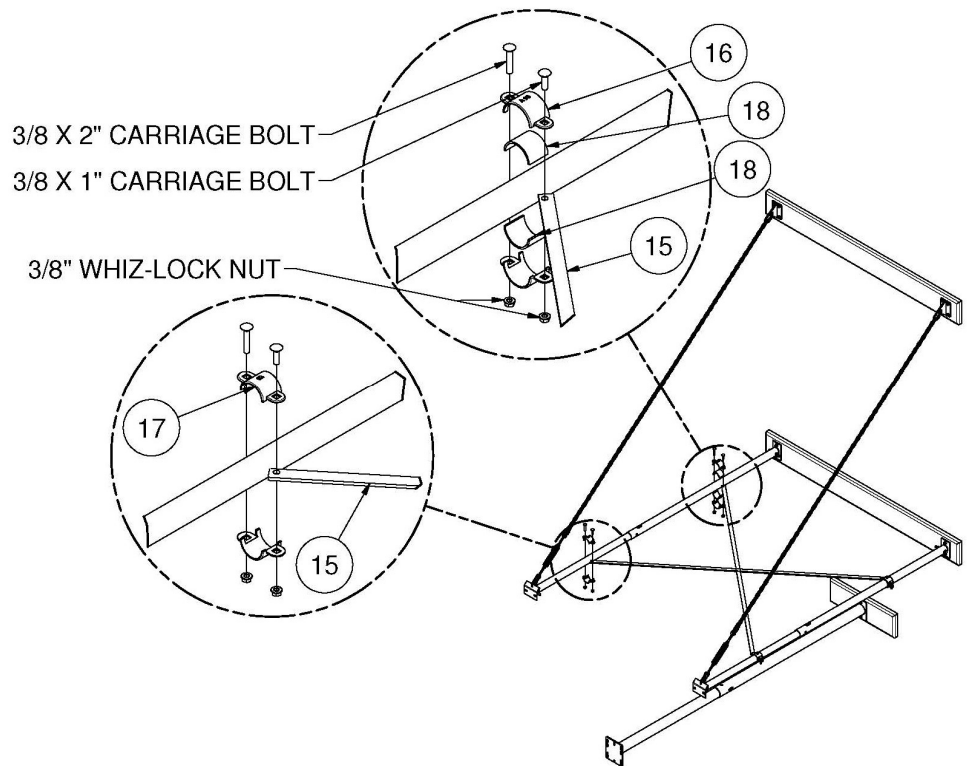

On the 9 Ft. to 12 Ft. models, two cross brace assemblies are required. Both are installed on the lower extension tubes and spaced equally. The spacer bushings (Item 18) are used with the clamp (Item 16) and installed on the outer extension tube. Clamp (Item 17) does not require spacer bushings and is installed on the inner extension pipe.

**FOR UNITS WITHOUT HEIGHT ADJUSTER CONTINUE TO PAGE 11
FOR UNITS WITH HEIGHT ADJUSTER PROCEED TO PAGE 13**

INSTALLING THE BACKBOARD WITHOUT A HEIGHT ADJUSTER

Support the outer portion of the extension arms with the scissor lift or scaffolding.

Attach the back board to the upper board mounts using the appropriate board mounting hardware.

Attach the board to the lower extension post using hex bolts to the back of the board and the carriage bolts through the goal and backboard.

Note: Glass backboard and carriage bolt hardware are shown. Other style of board may require different hardware.

Remove the support from the outer portion of the lower extension arms and allow the unit to hang on its own.

Check to make sure the backboard is plumb. Measure the distance from the wall to the face of the back board on each side. Loosen the set screws in the outer tubes and slide the inner extension arm in or out until the face of bank (FOB) is reached. Once both sides of the backboard are at the correct FOB and the frame is still square to the wall and the backboard is plumb, tighten the set screws.

Install the locking bolts on the upper extension arms the prevent movement of the arms.

Drill a 7/16" hole through the inner extension tube using the hole in the outer tube as a guide.

Install the 3/8" bolt (Item 24), locknut (Item 27) and tighten securely.

Install the locking bolts on the lower extension arm the prevent movement of the arm.

Drill a 9/16" hole through the inner extension tube using the hole in the outer tube as a guide.

Install the 1/2" bolt (Item 26), locknut (Item 28) and tighten securely.

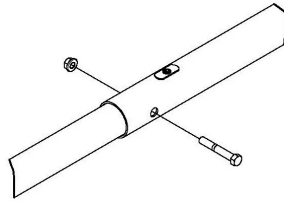
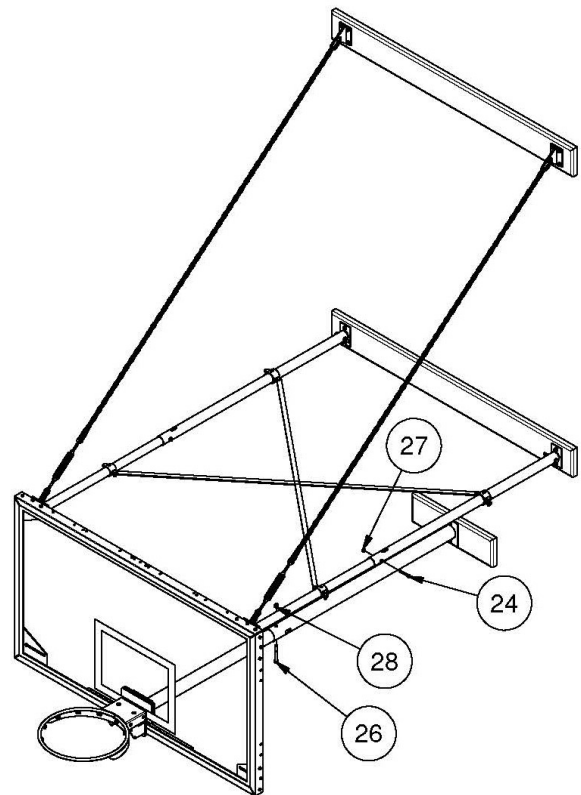
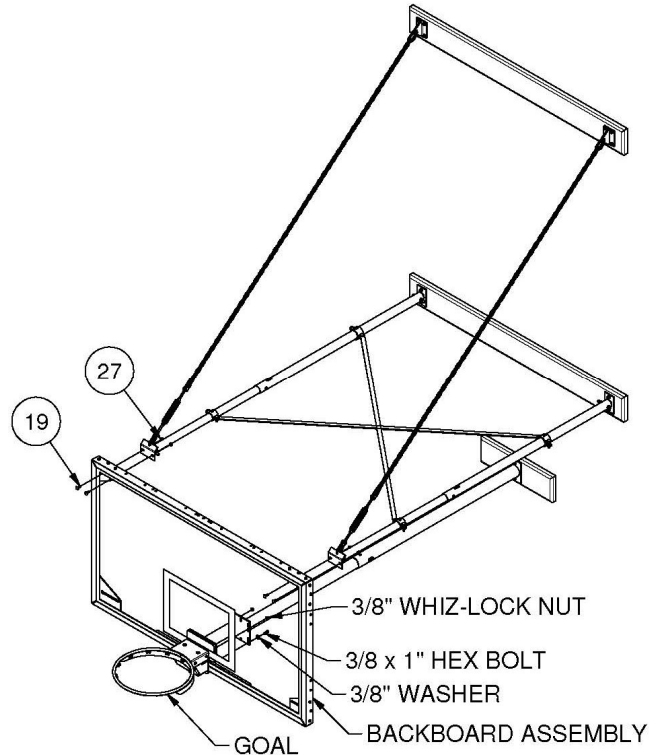

The final step of the assembly is to level the frame extension arm by adjusting the chain tension with the turnbuckles. It is important to not over adjust the chains as this causes undue stress on the chain anchor points. Chain tension should be no more than enough to level the side frame tubes.

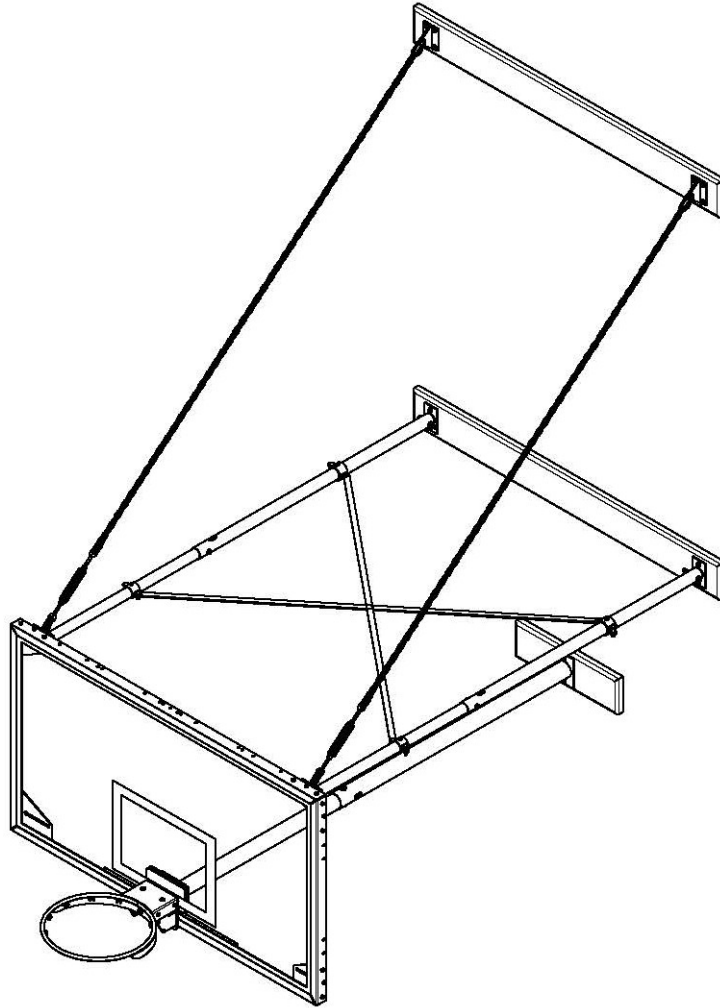

▲ CAUTION

Adjust chains only enough to level the frame extension tubes. **DO NOT** use chain adjustment to raise or lower goal height.

Improper chain adjustment can cause damage to frame when folding and/or failure of chain anchor

INSTALLING THE BACKBOARD WITH A HEIGHT ADJUSTER

Support the outer portion of the extension arms with the scissor lift or scaffolding.

Attach the upper height adjuster mounting angle using the 3/8 x 1" carriage bolts and whiz lock nuts.

Because the board to height adjuster mounting varies, specific instructions for mounting both the height adjuster and the board are supplied with the mounting kits.

The illustration below is for reference only and may not be the exact representation of the board or wall mount in your application. Please refer to the specific instructions supplied with the MTG KIT, HEIGHT ADJUSTER TO WM, and the MTG KIT BACKBOARD TO HEIGHT ADJUSTER.

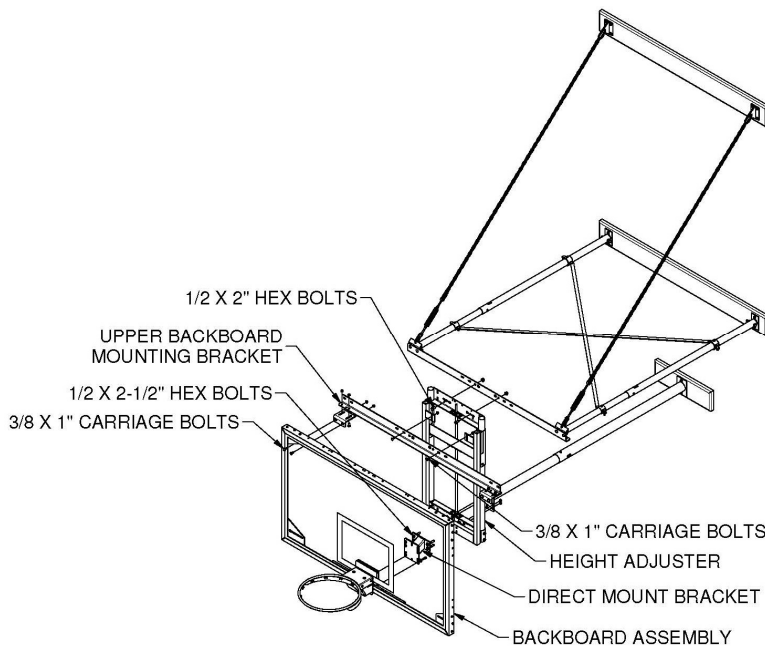
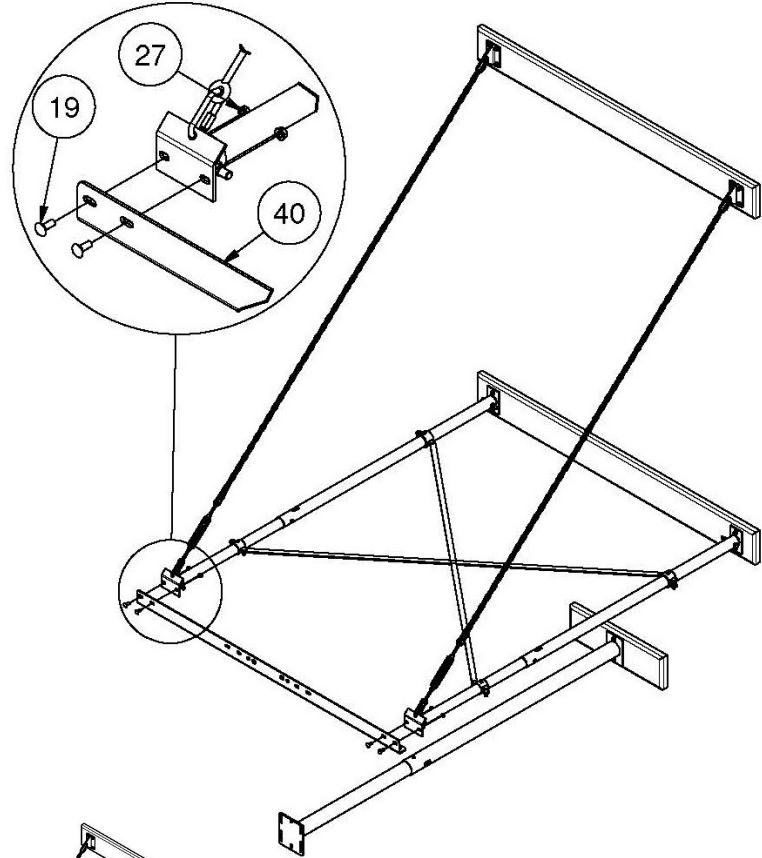

Once the height adjuster and backboard has been installed, final adjustments to the FOB and chain tension can be made.

Measure the distance from the wall to the face of the back board on each side. Loosen the set screws in the outer tubes and slide the inner extension arm in or out until the correct face of bank (FOB) is reached. Once both sides of the backboard are at the correct FOB and the backboard is plumb, tighten the set screws.

Install the locking bolts on the upper extension arms the prevent movement of the arms.

Drill a 7/16" hole through the inner extension tube using the hole in the outer tube as a guide.

Install the 3/8" bolt (Item 24), locknut (Item 27) and tighten securely.

Install the locking bolts on the lower extension arm the prevent movement of the arm.

Drill a 9/16" hole through the inner extension tube using the hole in the outer tube as a guide.

Install the 1/2" bolt (Item 26), locknut (Item 28) and tighten securely.

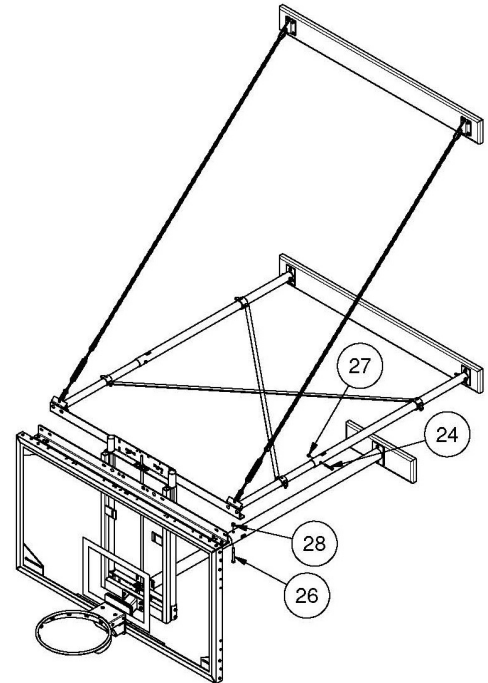
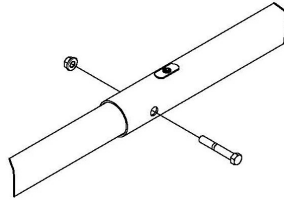

The final step of the assembly is to level the frame extension arm by adjusting the chain tension with the turnbuckles. It is important to not over adjust the chains as this causes undue stress on the chain anchor points. Chain tension should be no more than enough to level the side frame tubes.

⚠ CAUTION

Adjust chains only enough to level the frame extension tubes. **DO NOT** use chain adjustment to raise or lower goal height.

Improper chain adjustment can cause damage to frame when folding and/or failure of chain anchor

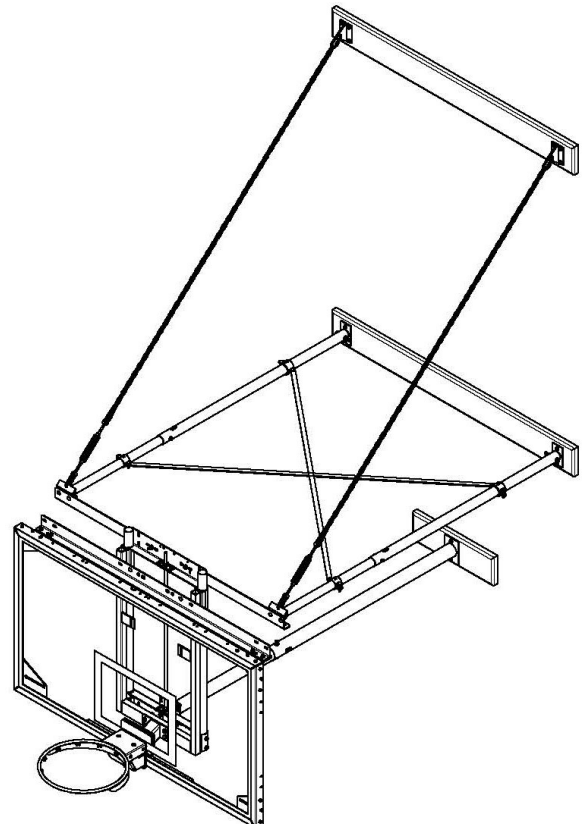



3 PT STATIONARY WALL MOUNT



ATTENTION: INSTALLER

To confirm that you have received all the parts, and to better serve you if you contact us, please fill out the following information and fax or mail to the address below.

Please refer to the facility name and/or the installation company below when you contact the factory and include it on any correspondence.

Please complete the checklist on the following page for each unit installed and include them with the fax or letter.

Facility/School Name:

Installation Date:

Installed by:

ASTM #:

Signature:

Date:

Fax to: 1-317-774-9841

Attn: Customer Service

Or

Mail to:

Customer Service

9200 E. 146th St., Ste. A

Noblesville, IN 46060

800-848-8034



3 PT STATIONARY WALL MOUNT



Model 2350 Installation Checklist

Date: _____

	Unit Number					
	1	2	3	4	5	6
Building structure has been approved for unit loads.	—	—	—	—	—	—
Attachment anchor system has been approved for the unit loads and installed per the structural engineer's specifications.	—	—	—	—	—	—
Washers have been installed under wood pad's carriage bolts.	—	—	—	—	—	—
Extension arms are level and square to the wall in the play position.	—	—	—	—	—	—
Board and goal are level, plumb and set at appropriate FOB (Face of Bank).	—	—	—	—	—	—
Goal height is correct.	—	—	—	—	—	—
Hardware is tight.	—	—	—	—	—	—
Quick links have been closed and tightened.	—	—	—	—	—	—
Height adjuster, if so equipped, is lubricated and operates smoothly.	—	—	—	—	—	—
See height adjuster, board, and goal for additional installation instructions and checks.						



3 PT STATIONARY WALL MOUNT



OPERATING INSTRUCTIONS

Always use the equipment in the manner intended. The manufacturer does not assume any liability for improperly used or improperly maintained equipment.

Always check for any loose connections, chains, or components before using the equipment. Contact the appropriate maintenance personnel if any components are noticed to be loose or out of place.



3 PT STATIONARY WALL MOUNT



MAINTENANCE INFORMATION – PLEASE RETAIN FOR FUTURE REFERENCE!!!

MODEL #2350 3 PT STATIONARY WALL MOUNT

MAINTENANCE OVERVIEW

!!!ALWAYS DISCONNECT POWER SOURCE BEFORE PERFORMING ANY MAINTENANCE CHECK OR OPERATION ON THIS EQUIPMENT!!!

STRUCTURE:

We recommend a yearly inspection (or more frequently depending on usage) of the nuts and bolts, checking for tightness. Refer to recommended bolt torque chart at the right.

RECOMMENDED BOLT TORQUE				
Bolt Size	Wrench Size	In-Lbs	Ft-Lbs	Nm
1/4"	7/16"	66 to 90	5.5 to 7.5	8 to 10
5/16"	1/2"	132 to 180	11 to 15	15 to 20
3/8"	9/16"	234 to 318	19.5 to 26.5	27 to 36
7/16"	11/16"		31 to 42.5	43 to 58
1/2"	3/4"		47 to 65	64 to 88
9/16"	7/8"		68 to 90	93 to 122
5/8"	15/16"		94 to 130	128 to 176
3/4"	1-1/8"		166 to 230	226 to 312
7/8"	1-5/16"		269 to 372	365 to 504
1"	1-1/2"		402 to 566	546 to 767

Important Note: The bolts that secure the extension arms to the hinges and the center slide tube to the hinges have nylon locking nuts and these should NOT be torqued to the value in the chart. These nuts should only be tightened until the nut just engages the hinge bracket. Do not overtighten the nut as this will cause binding and excessive wear on the bushings and the tubes.

TURNBUCKLES AND CHAINS:

Check all turnbuckles and support chains for signs of wear or loose connection links.

Confirm all extension arms are level and square to the wall.

BACKSTOP FRAME COMPONENTS

Check for dents, on frame tubes, bent tubes, worn bushings, bent or broken hinge brackets.

Check the wood pads and wood pad wall anchors. Make sure wood pads are not loose to the wall. Make sure wood pads are not cracked or split.

This Model #2350 3 PT Stationary wall mount has been custom manufactured according to the Owner's/Architect's specifications. When operated and maintained with proper care, this backstop should provide years of safe, trouble free service.



3 PT STATIONARY WALL MOUNT



ATTENTION: MAINTENANCE DEPARTMENT

To confirm that you have received maintenance and warranty information, and to better serve you if you contact us, please fill out the following information and fax or mail to the address below.

Please refer to the facility name and/or the installation company below when you contact Performance Sports Systems and include it on any correspondence.

I have received the maintenance and warranty information provided by Performance Sports Systems on the 2350 3 PT STATIONARY wall mount backstop.

Facility/School Name: _____

Installation Date: _____ Installed by: _____

Maintenance Dept. Contact: _____

Signature: _____ Date: _____

Fax to: 1-317-774-9841

Attn: Customer Service

Or

Mail to:

Customer Service

9200 E. 146th St., Ste. A

Noblesville, IN 46060

800-848-8034



Maintenance Check Sheet

Refer to Maintenance Overview (page 18) for recommended inspection frequency.

Date: _____

Unit: _____

Wood Pads / Anchors

-Wood pads, splitting, chipping, etc. OK Repair Replace

-Anchors/Bolts OK Repair Replace

Unit Supports / Brackets / Hinges

-Tubes; dents, stress spots, etc. OK Repair Replace

-Bolts; loose, deformed, etc. OK Repair Replace

-Brackets/Hinges; bent, not rotating, etc. OK Repair Replace

Chains

-Chains; deforming, broken/bent links OK Repair Replace

-Hardware; Quick links OK Repair Replace

Sliding Components; AAG (IF APPLICABLE)

-Lubrication OK Repair



Gared Holdings, LLC

Performance Sports Systems
9200 E. 146th Street
Noblesville, IN 46060

800-848-8034
www.perfsports.com

Gared Sports
9200 E. 146th Street
Noblesville, IN 46060

800-325-2682
www.garedsports.com