



Fold Up Divider Curtain

Model: 4020



Installation, Operation and Maintenance Instructions

.....
Please read all instructions before attempting installation or operation of these units
.....

SAVE THESE INSTRUCTIONS FOR FUTURE USE

PUBLICATION No.
7 0 1 7 5 1 2 6 2

Issued
May 30, 2019



Fold Up Divider Curtain



Table of Contents

<u>Section</u>	<u>Page No.</u>
Introduction	2
Parts illustrations	3
Parts checklist	4
Tools required	5
Installation instructions	6
Installing the drive tube and motor	7
Installing the top and bottom Batten	8
Raising curtain to overhead	9
Installing the lift cables	10
Connecting the wiring	15
Temporary wiring	16
Setting motor limits	16
Permanent wiring	18
Wiring diagram	19
Operation guidelines	22
Maintenance	24
Product registration form	25



Fold Up Divider Curtain



Introduction

Thank you for your purchase of a Model 4020 Fold Up Divider Curtain. To ensure that our equipment will provide years of use to you, we are including this installation, operation, and maintenance guide. This guide will provide information on the proper assembly and installation methods, operating procedures, and preventative maintenance of your gymnasium divider curtain.

Please note that a Bill of Materials is being included with this guide. Please check that all of the parts called out on the Bill of Materials are present prior to beginning assembly and setup. Please do not substitute for factory parts. Please contact the customer service department and allow them to determine if substitute parts are acceptable.

It is recommended that an individual who has been properly trained perform assembly and set up of the divider curtain. No one under the age of 18 should attempt assembly or set up of the unit, unless properly supervised.

To prevent normal wear and tear from shortening the life of the unit, preventative maintenance inspections and repairs should be performed at least once per year. If the units are subject to high or unusual usage, inspections should be scheduled to occur more frequently. If items are found to be nonconforming, replacements can be ordered from the manufacturer or one of our authorized dealers. When contacting customer service, please have information regarding the dealer/installer who sold the unit, the name of the project, and any applicable warranty information.

Please note that the manufacturer assumes no responsibility for the building structure to support our products. We believe it is the responsibility of the building designers to determine the correct structure to support our products. We will provide the project structural engineer with all the required weight and loading information for the specific project in order for them to calculate the appropriate structure.

Before proceeding with assembly, read all instructions and assembly procedures. Make sure all parts have been received and are not damaged. Verify all parts listed on packing list are present prior to installation. Contact the customer service department for assistance with replacement of any parts missing or damaged.

Read and understand the following warnings to prevent possible personal injury and potential damage to the equipment during assembly, setup, and operation.

Parts Illustrations



1015-09-00



1023-09-00

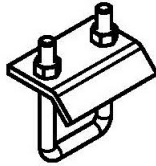

101173820

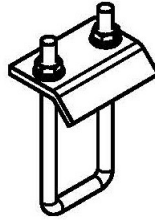

101173821



101173823



101173824



1770-27-08



6050-11-00

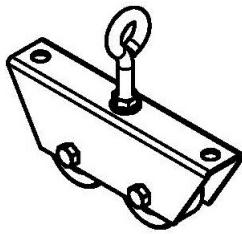

1751-27-08

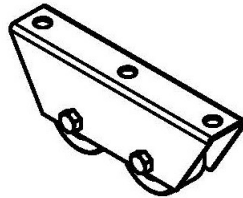

1753-27-08

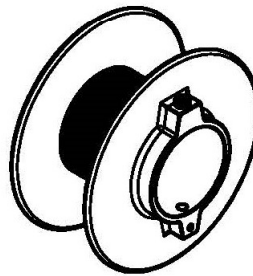

Cast Aluminum Spool
1752-27-08

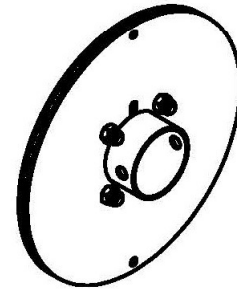

Alternate Steel Single
Groove Spool
705851265



701651249



701001248



3109-30-00



9806-11-00



111075939

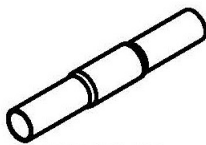

701651236

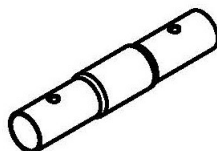

701651237

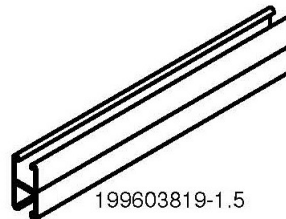

199603819-1.5

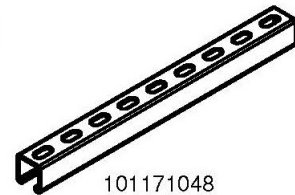

101171048

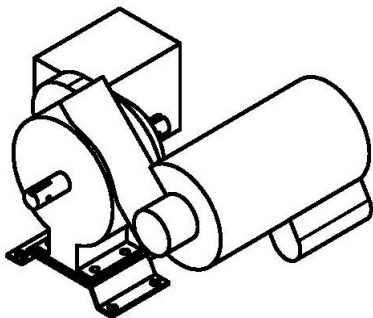

4002

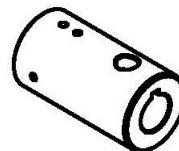

704955387



Fold Up Divider Curtain



Parts Checklist

Item	Part Number	Description	QTY	Unit QTY
1	1900-04-00PC	TUBE,RND,1.9 OD X 0.083 WALL	See Packing List	
5	2375-04-00PC	TUBE,RND,2.375 OD X 0.083 WALL	See Packing List	
6	199603819	UNI-STRUT, DOUBLE	See Packing List	
17	3013-30-00	1/8" GALVANIZED AIRCRAFT CABLE-7X19	See Packing List	
7	4020	FOLD-UP CURTAIN FABRIC	1	
8	4102	CURT HOIST 3/4HP,115V,1P,60HZ 120:1	1	
9	701001248	CABLE SLEEVE TO PROTECT BOTT. POCKET	8	
10	701651249	BLACK RUBBER FOOT W/ DRILLED HOLE	8	
11	1015-09-00	1.9" END CAP	4	
12	1023-09-00	2 3/8" END CAP	2	
13	1751-27-08	1751 CARRIER BRACKET ASSEMBLY	8	
14	1752-27-08	1752 CAST ALUMINUM REEL	8	
15	1753-27-08	1751 CARRIER W/O EYEBOLT	2	
16	1770-27-00	ALUM. BAND CLAMP	8	
18	3109-30-00	1/8" CABLE CLAMP	8	
19	101171048	UNI-STRUT, SINGLE, 18"	8	
20	101173820	SINGLE STRUT ` CLAMP	16	
21	101173821	DOUBLE STRUT BEAM CLAMP	4	
22	101173823	3/8"-16 STRUT KWIK WASHER	20	
23	701651236	SLEEVE, 4" DBL CRIMPED 1.9"	4	
24	701651237	SLEEVE, 4" DBL CRIMPED 2.38"	2	
25	704955387	LYNRUS COUPLER FOR DRIVE TUBE	2	
26	709051241	CHANNEL, BATTEN DRILL TOOL	1	
27	501-5-18-24	BOLT, CARRIAGE 5/16-18 UNC X 1.5	8	
28	502-6-16-24	HEX BOLT, 3/8-16 UNC X 1.5	4	
29	502-8-13-48	HEX BOLT, 1/2-13 UNC X 3	6	
30	511-4-20-8	SET SCREW, CUP POINT 1/4-20 UNC X 0.5	4	
31	541-5-18	HEX NUT 5/16-18	8	
32	548-6-16	HEX NUT, SERRATED FLANGE 3/8-16	56	
33	548-8-13	HEX NUT, SERRATED FLANGE 1/2-13	6	
34	561-6	FLAT WASHER 3/8	8	
35	562-6	SPLIT LOCK WASHER 3/8	4	
36	6050-11-00	DRIVE RIVET, 3/16" X 3/8" ALUM	8	
37	101155683	3/8"-16 X 18" THREADED ROD	16	
38	101651064	1/4" SQUARE KEY X 2-1/4"	2	
39	111075939	SPRING PIN, 3/16 X 2.0	2	

IMPORTANT: Check packing list supplied with the product. Some parts required to attach the curtain to the overhead structure may not be listed in the above table because the connections are job dependent and only listed on the packing list for the job.



Fold Up Divider Curtain



INSTALLATION

Tools Required:

- Hammer
- 3/8" Hand Drill
- Drill Bits – 3/16" and 1/2" with 3/8" Shank
- 3/8" Ratchet Wrench with 1/2" and 9/16" Sockets
- 1/2" Ratchet Wrench with 9/16", 11/16" and 3/4" Sockets
- Wrenches – 1/2", 9/16", 11/16" and 3/4"
- 3/16" Allen Wrench
- 4" C-Clamps (2)
- 4' Level
- File (half round)
- 25' Tape Measure
- Cable Cutters
- Utility Knives
- Wire Stripper
- Small Screwdriver
- Ratcheting Pulleys (3-5 depending on length of curtain)
- 75' Ropes (3-5 depending on length of curtain)
- 100' 14-4 Wire (depending on length of curtain)
- Wire Nuts
- Duct Tape
- Block of Wood (for tapping)
- Broom
- Shop Vac
- Protective Covering for Floor

IMPORTANT: A minimum of three people (more, depending on size of curtain) is recommended to be available to assist with the installation.

RECOMMENDED BOLT TORQUE				
Bolt Size	Wrench Size	In-Lbs	Ft-Lbs	Nm
1/4"	7/16"	66 to 90	5.5 to 7.5	8 to 10
5/16"	1/2"	132 to 180	11 to 15	15 to 20
3/8"	9/16"	234 to 318	19.5 to 26.5	27 to 36
7/16"	11/16"		31 to 42.5	43 to 58
1/2"	3/4"		47 to 65	64 to 88
9/16"	7/8"		68 to 90	93 to 122
5/8"	15/16"		94 to 130	128 to 176
3/4"	1-1/8"		166 to 230	226 to 312
7/8"	1-5/16"		269 to 372	365 to 504
1"	1-1/2"		402 to 566	546 to 767

INSTALLATION INSTRUCTIONS

IMPORTANT: Locate, identify and count all parts before starting the installation to ensure that all are correct and correspond to the packing list/production drawings. Also review production drawings to ensure that building conditions have not changed since the initial field check. Verify overall height and width noted on drawings.

Installation Steps:

1. Site preparation
2. Install overhead support hangers
3. Assemble drive tube and motor
4. Install top and bottom batten pipes in curtain fabric
5. Raise assembled curtain to overhead and connect top batten to support hangers
6. Allow curtain to hang fully extended and adjust height off finished floor as required
7. Install lift cables
8. Connect wiring.
9. Set motor limit switches
10. Test divider curtain operation

Step 1 – Site Preparation:

Finished floor and curtain are easily damaged; therefore care should be taken to protect both. Make sure area is clean and free of debris. Sweep floor before laying protective covering. Protective covering should be at minimum the length and width of curtain. Have shop vacuum handy to sweep up any debris or metal shavings during installation.

Step 2 – Installing Overhead Support Hangers

Because the overhead structure will vary per project, the installation configuration, dimensions, and details are reflected in the production drawing package shipped with the product. Refer to the production drawings for specifics on your particular installation as they may not be the same as illustrated in this manual.

Note: This manual illustrates a direct attach parallel to truss application.

It is important to remember that the divider curtain will not roll correctly if the overhead connections are not installed level and in line. Make sure to follow the directions in the production drawing package for installing these connections to provide a level and aligned attachment for the curtain fabric.

Refer to the installation drawing package provided with the shipment and install the motor hangers onto the building truss in the location shown on the plans.

Slide the 4 Kwik Washers into the uni-strut (2 in each strut).

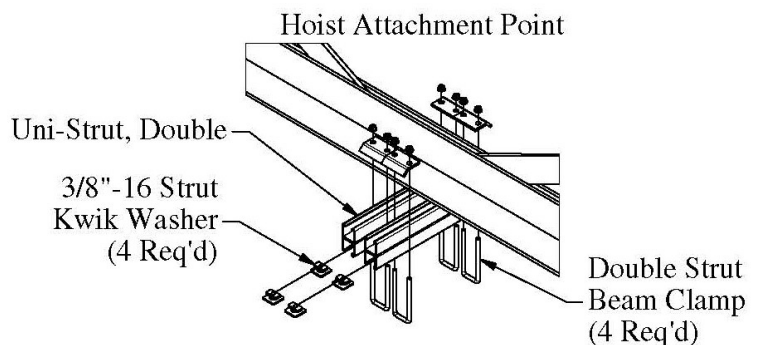

Tighten the uni-strut beam clamps. The Kwik washers will be used to attach the hoist motor.

Install the single carrier assemblies at the locations noted in the plans.

Slide the 2 Kwik washes into the uni-strut and tighten the beam clamps. Thread the 3/8" threaded rod into the Kwik washers and tighten a 3/8" whizlock nut against the Kwik washer to lock the threaded rod in place.

Install a whizlock nut onto each of the threaded rod (locking side down) several inches above the bottom of the rods.

Slide the 1751 carrier bracket (rollers up) onto the threaded rods and install another 3/8" whizlock nut (locking side up) onto each threaded rod. Leave these connections loose for now. They will be adjusted and tightened once the drive shaft is installed and leveled.

Install the double carrier assemblies on each end as noted on the installation plans.

Slide the 2 Kwik washes into the uni-strut and tighten the beam clamps. Thread the 3/8" threaded rod into the Kwik washers and tighten a 3/8" whizlock nut against the Kwik washer to lock the threaded rod in place.

Install a whizlock nut onto each of the threaded rod (locking side down) several inches above the bottom of the rods.

Slide the 1751 carrier bracket W/O eyebolt onto the threaded rods (rollers down) and install another 3/8" whizlock nut (locking side up) onto each threaded rod. Adjust the carrier up far enough on the threaded rod to allow room for another carrier bracket at the bottom.

Install a whizlock nut onto each of the threaded rod (locking side down) several inches above the bottom of the rods.

Slide the 1751 carrier bracket (rollers up) onto the threaded rods and install another 3/8" whizlock nut (locking side up) onto each threaded rod. Leave these connections loose for now. They will be adjusted and tightened once the drive shaft is installed and leveled.

Step 3 – Assemble Drive Tube and Motor

1. Lay drive tube on the floor aligned with the overhead structure if possible. Locate the lengths of drive tube according to the installation print provided with the shipment. (Depending on the overhead structure, drive tube may be longer on one side and the motor may not fall at center of curtain.)

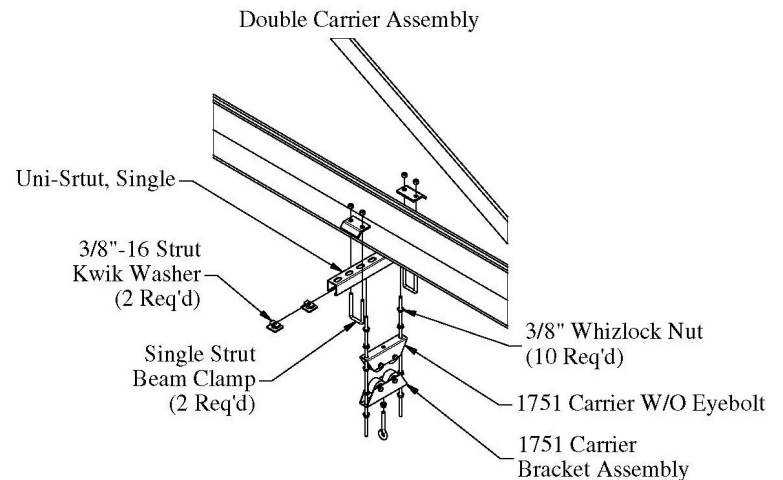
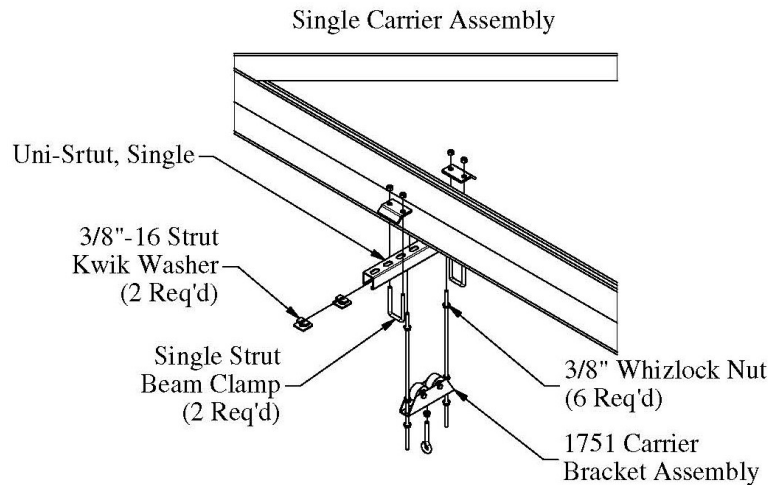

2. Install the motor to the motor support struts using the 3/8" x 1-1/2" hex bolts and lock washers. These bolts will tap into the Kwik washers installed earlier. Torque these bolts to the proper torque as shown in the bolt torque chart.
3. Slide the couplers onto each end of the motor shaft making sure the 1/4" square keys are fully seated in the keyways. Line up the hole in the couplers with the hole in the shaft and insert the 3/16" spring pin in each coupler.

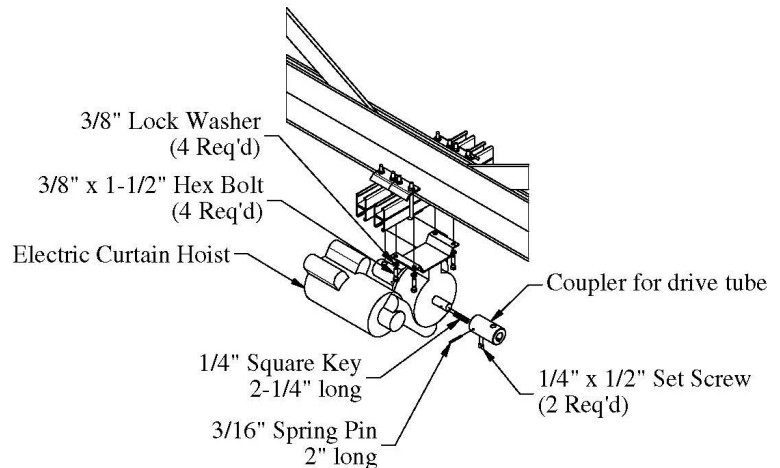

▲ CAUTION

Failure to install the spring pin could allow the coupler to slip off the shaft allowing the curtain to free fall resulting in damage to the curtain and/or injury to personnel.

4. Tighten the two 1/4" set screws in each coupler securely.
5. With the drive tube sections lying on the floor, slide the cable spools onto each section of tube in the approximate location as noted on the installation plans. It is critical that the spools are all facing the same direction all along the drive tube.

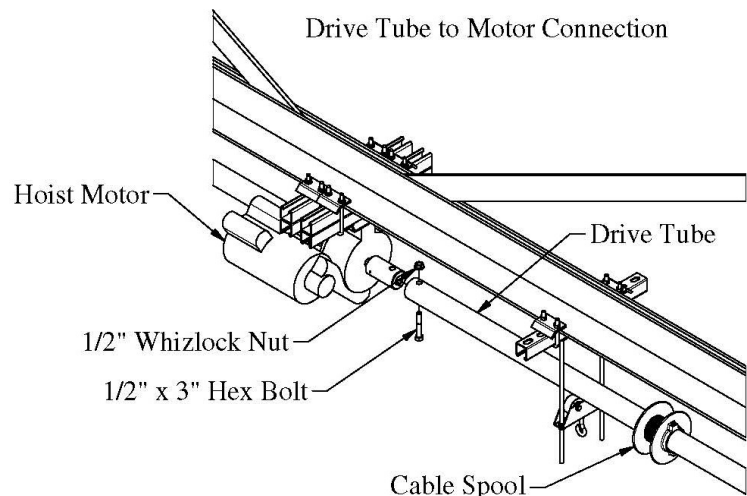
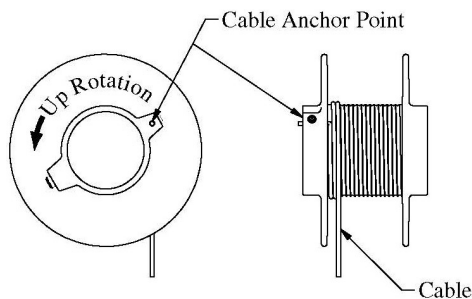

Make sure all the cable anchor point ends of the spools are facing the same direction on the drive shaft.

▲ CAUTION

Failure to install the spool in the same direction on the drive shaft will result in several problems with the raising and lowering of the curtain. Some issues can cause damage to cables and vinyl..

6. Starting at the winch and working outward toward each end, install the drive tube sections to the winch. Lift the drive section into the carriers and slide the end of the drive tube onto the coupler. Align the hole in the drive shaft to the hole in the coupler and install the 1/2" x 3" hex bolt and whizlock nut.

7. Tighten and torque the bolt connections to the hoist couplers.
8. Adjust the carrier brackets with the whizlock nuts on the threaded rods until the drive tube is level. Tighten the whizlock nuts on the top of the carrier bracket to hold the bracket in position. Torque these nuts.
9. Repeat these steps until all of the drive tube sections are installed and levelled.

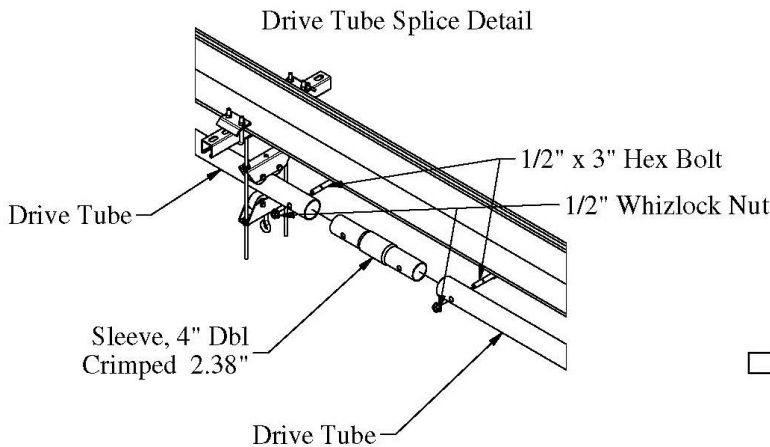

10. Connect the sections of drive pipe with the double crimped sleeve for 2.38" pipe. Slide the sleeve into the drive pipe and align the holes. Install the 1/2" x 3" hex bolt and 1/2" whizlock nut.

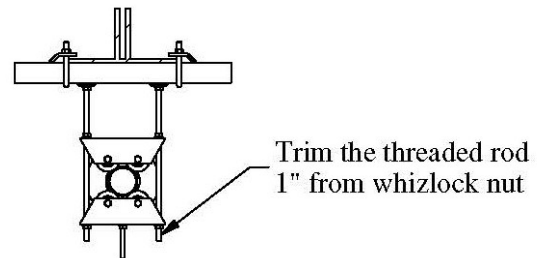

11. When all of the drive pipe sections have been installed and levelled, trim the 3/8" threaded rods at each carrier. Leave approximately 1" of rod from the whizlock nut.
12. Cap the ends of the drive tube with a 2-3/8" plastic pipe cap.

Step 4 – Install Top and Bottom Batten Tubes in Curtain Fabric

Installing Bottom Batten

Bottom Batten consists of three or more pieces (depending on size of curtain) of 1.9" O.D. pipe. End batten tubes are drilled on one side only.

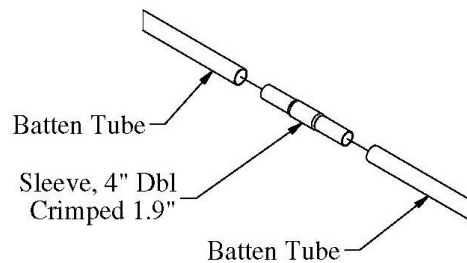

1. Remove acorn nut and bolt from bottom vinyl pocket.
2. Install a plastic cap on the non-drilled end piece of bottom batten pipe and slide into curtain pocket, leaving about 1' of pipe exposed. Slide first splice into pipe end and using the batten drill tube, drill the batten tube and splice and install the drive rivet.
 - After hole is drilled, hammer in 6050-11-00 Drive rivet
 - Align edge of tool to edge of pipe
3. Slide next piece of pipe onto splice, drill and rivet the tube to the splice.
4. Continue above procedure until bottom batten is complete and install a plastic cap on the finished end.
5. Replace acorn nut and bolt, and tighten securely.

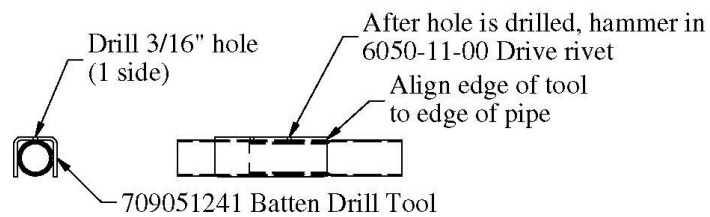



Fold Up Divider Curtain



Installing Top Batten

Top Batten consists of three or more pieces (depending on size of curtain) of 1.9" O.D. pipe. End batten tubes are drilled on one side only.

1. Install a plastic cap on the non-drilled end piece of bottom batten pipe and slide into curtain pocket, leaving about 1' of pipe exposed. Slide first splice into pipe end and using the batten drill tube, drill the batten tube and splice and install the drive rivet.
2. Slide next piece of pipe onto splice, drill and rivet the tube to the splice.
6. Continue above procedure until bottom batten is complete and install a plastic cap on the finished end.
3. Note the top batten is longer than the mesh width, so about 3" to 6" of pipe will extend from the mesh panel on both ends.

The curtain is now ready to be raised to the overhead.

Step 5 – Raise Assembled Curtain to Overhead and Connect To Support Hangers

The following methods of raising the curtain are merely suggestions, as each installation will vary depending on curtain size and facility. Additional equipment needed to raise curtain is not supplied, and is listed under "optional" on the Tool List. We recommend three or more people be available to assist in raising the curtain. If your installation is particularly difficult due to facility conditions, please contact Performance Sports for additional information.

Method #1 -

Make sure curtain is aligned with overhead drops and evenly spaced between end brackets. For convenience, steps 1 and 2 can be done while installing curtain overhead.

1. Evenly space and securely attach standard or ratchet pulleys above overhead using chain or rope.
2. Thread rope through pulleys allowing enough length for rope to dangle on floor.
3. On top batten of the curtain, make a small hole (3/8" or 1/2" depending on rope size) in the mesh loop to allow the rope to connect to the batten pipe, spacing each hole to match pulleys attached to overhead. Make sure the holes are as small as possible so as not to be noticeable once the curtain is raised.
4. Insert ends of ropes through holes in the mesh and tie securely around the top batten.
5. Leaving curtain unrolled, slowly and evenly begin to raise curtain.
6. Once curtain has reached overhead assemblies, make sure ratchet pulleys are secure, or if using standard pulleys, rope is securely tied.

Method #2

1. Using small, 500 lb. capacity electric hoists, secure to hoists above overhead.
2. Attach pulleys using rope or chain, and thread rope through, allowing rope to dangle to ground.
3. Follow steps in Method #1, beginning with step #3.

Method #3

1. If two or more lifts are available, position the lifts parallel to the overhead structure and bring the top batten of the curtain onto the lifts making sure to distribute weight evenly. Secure top batten and slowly raise lifts in an even fashion allowing the curtain to unfold and drape to the floor until desired height is achieved.
2. Attach top batten to the overhead structure with connections as shown in the assembly drawings shipped with the product.

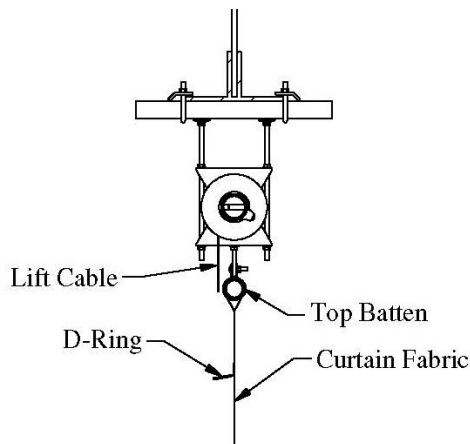
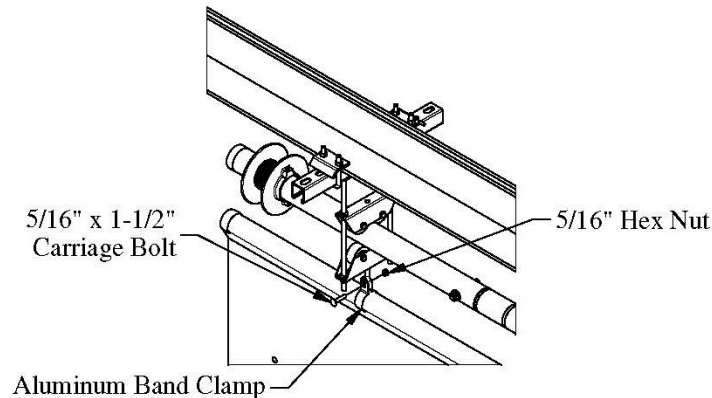

When installing a curtain with D-Ring cable guides instead of grommets, Make sure to install the fabric with the D-Ring side of the curtain on the same side as the lifting cable on the spools. If the D-Rings are on the opposite side from the lifting cable, damage to the curtain fabric will occur.

CAUTION

When installing a D-Ring style curtain, make sure the D-Rings are on the same side as the lifting cable on the spool.

Failure to install the D-Rings on the same side as the lift cable will cause the cable to rub on the top batten and wear holes in the mesh of the curtain.

Step 6 – Allow Curtain to Hang Fully Extended and Adjust Height off Finished Floor

With the curtain hanging fully extended, measure the distance from the finished floor to the bottom of the bottom batten. The dimension should be between 1.5” and 2” above the finished floor. It may be necessary to adjust the hangers at the overhead structure to achieve the desired dimension.

Check the level of the drive tube and adjust the hangers at the overhead as required to make sure the drive tube is level.

Step 7 – Install the Lift Cables

Grommet Style Curtains (for D-Ring style curtains, skip this section)

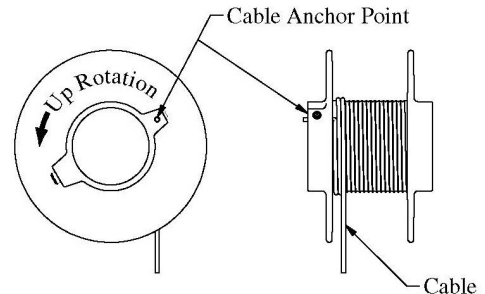
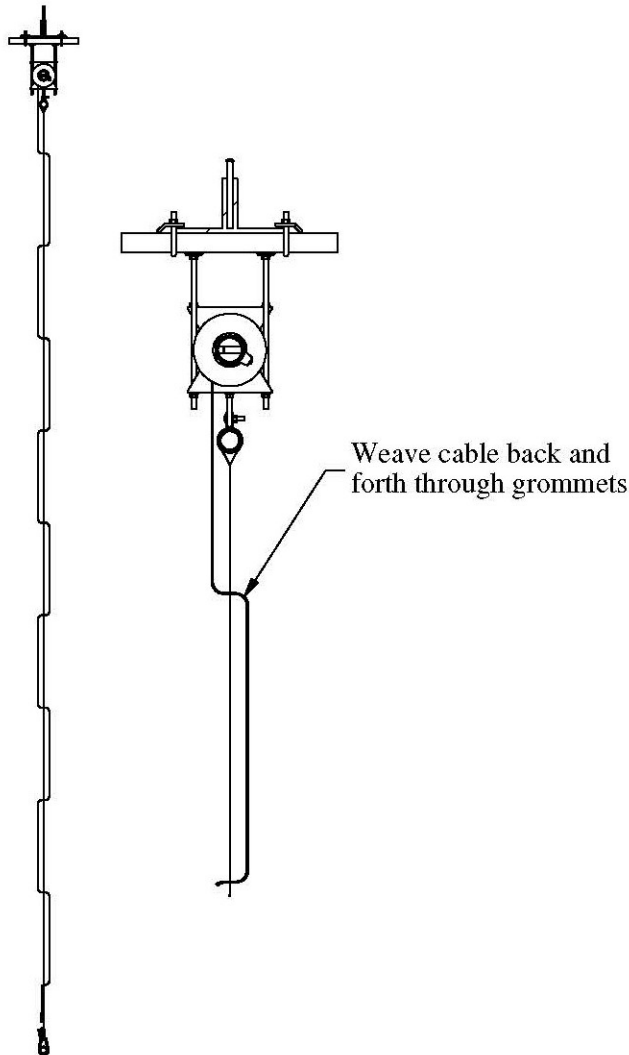

Aluminum Spool Cable Routing

1. Insert one end of the cable through the cable anchor point hole in the side of the aluminum spool and tighten the set screw securely.
2. Note the direction of the groove spiral and wrap 2 to 3 wraps of cable onto the drum making sure it is seated fully in the drum grooves.
Duct tape can be used to hold the cable wraps in position until the cable routing has been completed on the entire curtain.
3. Take the loose end of the cable and weave it back and forth through the grommets of the curtain.
4. Once the cable has been routed through the grommets the entire height of the curtain, repeat this process for all of the remaining spools.
5. After all cables have been routed through

the curtain, the connections to the bottom batten can be made. See the section on “Bottom Batten Attachment” for making this connection.

Alternate Single Groove Spool

1. When the alternate single wrap spools are used, fish the loose end of the cable through the slot in the disc.
2. Loop the cable back onto itself
3. Install a 1/8” cable clamp to secure the loop onto the cable.
4. Pull all of the slack out of the cable making sure the cable clamp is tight against the disc.

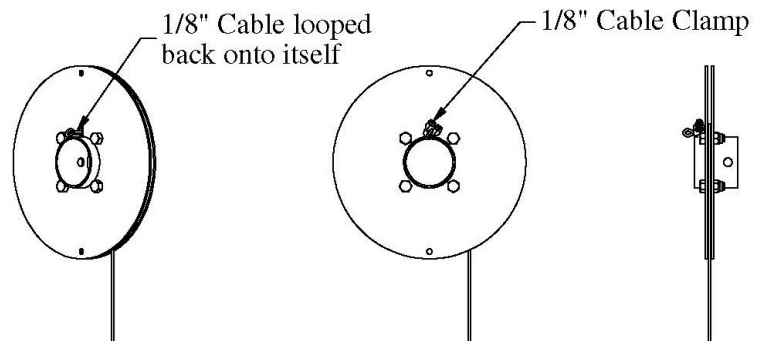

D-Ring Style Curtains

Aluminum Spool Cable Routing

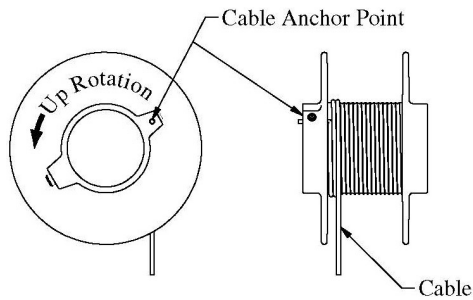

1. Insert one end of the cable through the cable anchor point hole in the side of the aluminum spool and tighten the set screw securely.
2. Note the direction of the groove spiral and wrap 2 to 3 wraps of cable onto the drum making sure it is seated fully in the drum grooves.
Duct tape can be used to hold the cable wraps in position until the cable routing has been completed on the entire curtain.
3. Take the loose end of the cable and pull it through the D-Rings of the curtain.
4. Once the cable has been routed through the D-Rings the entire height of the curtain, repeat this process for all of the remaining spools.
5. After all cables have been routed through the curtain, the connections to the bottom batten can be made. See the section on "Bottom Batten Attachment" for making this connection.

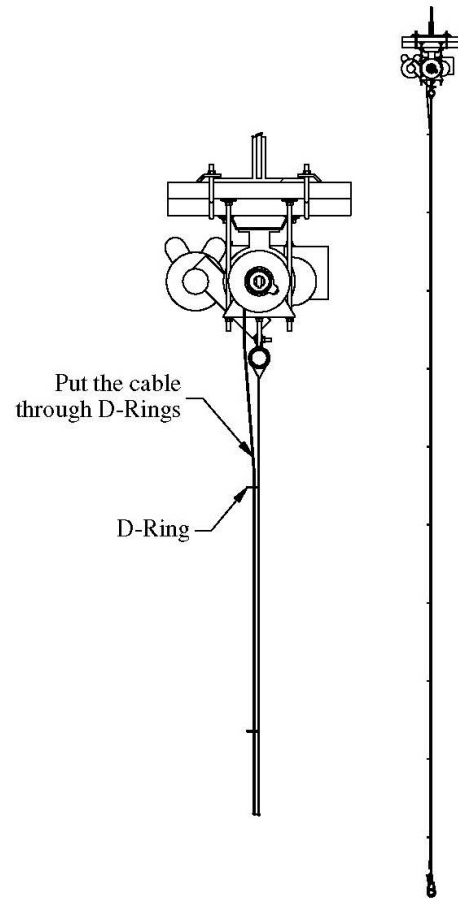

Alternate Single Groove Spool

1. When the alternate single wrap spools are used, fish the loose end of the cable through the slot in the disc.
2. Loop the cable back onto itself
3. Install a 1/8" cable clamp to secure the loop onto the cable.
4. Pull all of the slack out of the cable making sure the cable clamp is tight against the disc.

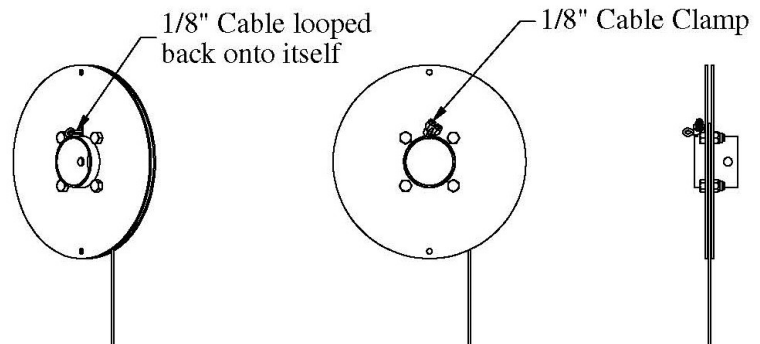

Step 8 - Making the cable connection at the bottom batten.

1. After the cable runs through the last d-ring or grommet, it will be inserted through the 1/4" hole on top of the rubber foot.
2. Run the cable through the washer then the entire cable sleeve.
3. Each side of the curtain's bottom pocket has a grommet. The cable will go through both grommets and wrapping around the outside of the fabric. (see diagram).
4. Attach the two cables together with the cable clamp. the cable clamp should be located directly above the ends of the cable sleeve.
5. (do not attach clamp over the black sleeve)
6. It is recommended not to cut the cable lines until all adjustments have been made.
7. Once cable lines are correct, cut the cable end leaving a couple inches past the cable clamp. The cut cable end and the clamp will be pushed into the rubber foot.

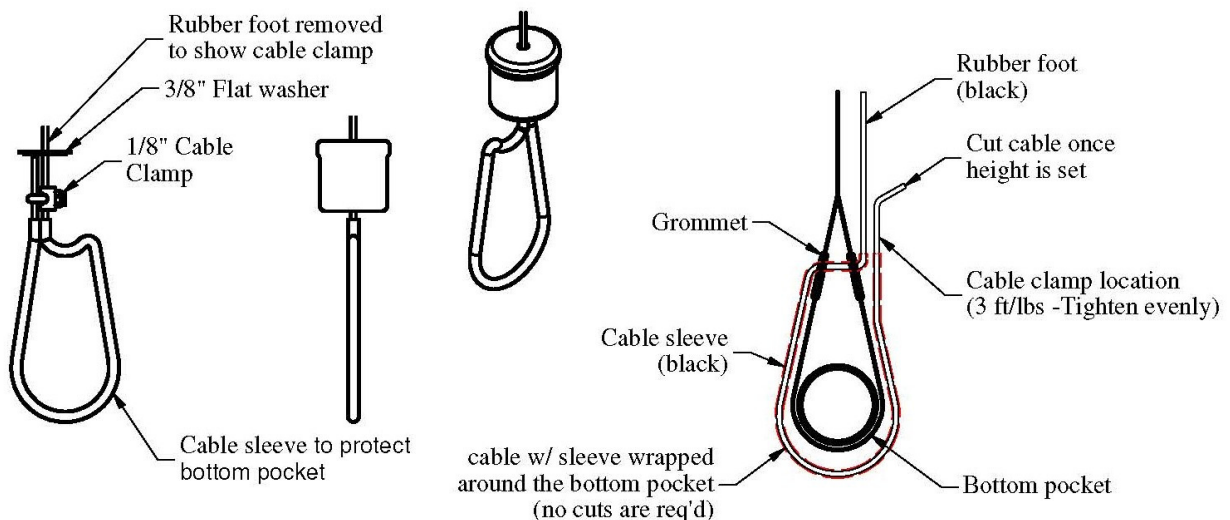

Step 9 – Connect Wiring

Most installations will require temporary wiring to be connected for power to set the motor limits and test the curtain. Permanent wiring will be installed later by the electrical contractor.

For temporary power to the motor, a test cord as shown can be manufactured locally or purchased from the factory. In order to provide the required voltage and amperage to the motor, the cord must meet the required wire sizes for the specified distance.

Extension cord for testing must be 16-3 or heavier up to 25 feet run, 14-3 or heavier for 25 to 50 feet run, 12-3 or heavier for 50 to 90 feet run, and 10-3 or heavier for 90 to 140 feet runs.

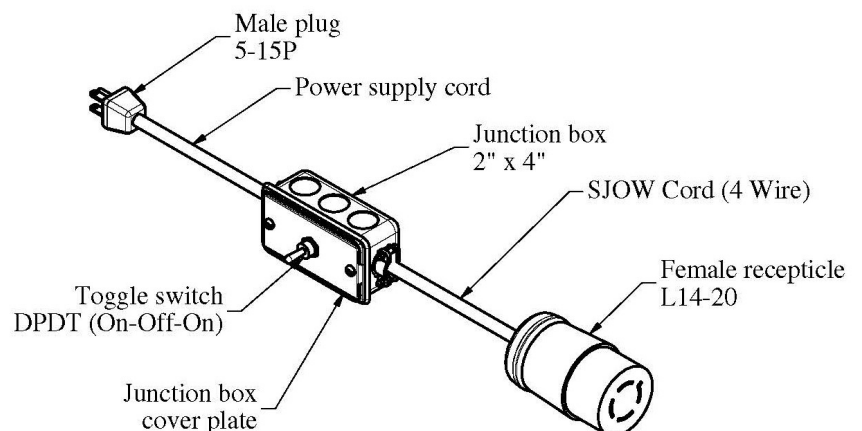

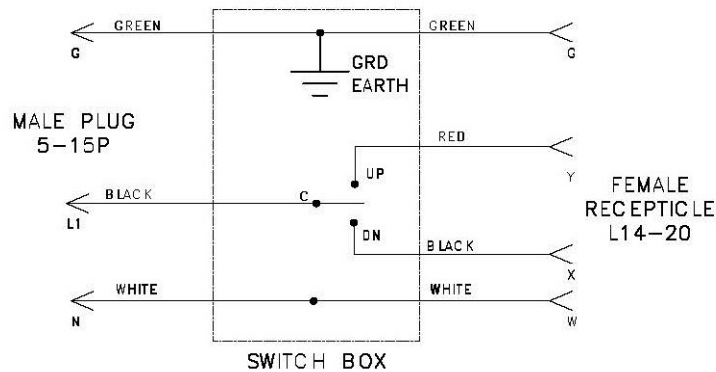

Test Cord Schematic

⚠ CAUTION

Operating the motor with insufficient voltage and/or amperage will damage the motor control box.

Damage caused due to inadequate electrical supply will not be covered under warranty.

Setting Limit Switches

1. With the curtain in the down position, there should be about 2” of clearance between the bottom of the curtain and the floor. Be sure that the hoist is unplugged before proceeding.
2. Make sure the hoist motor is UNPLUGGED from the test cord.
3. Loosen the retaining screw on the limit box cover and remove the cover.
4. Press the black index locking bar away from the down direction index wheel so it can rotate freely. Rotate the wheel until the switch “clicks” indicating that the switch is active.
5. Connect the power by plugging the motor into the test cord and raise the curtain to the up position. Check that the curtain is folding correctly and not creasing or binding the vinyl.

⚠ WARNING

The motor and electrical circuit is now HOT.
Do not handle any wires, use only the key switch to operate the curtain.

6. The curtain should be raised no higher than necessary and the grommets or D-rings should fold onto on themselves evenly. Uneven folding of the vinyl can cause excessive wear.
7. Press the black index locking bar away from the up direction index wheel so it can rotate freely. Rotate the wheel until the switch “clicks” indicating that the switch is active.
8. Reconnect the power.
9. The curtain should be raised and lowered several times to make sure that the cables are tracking properly and the limit switches are set correctly. Make sure that the bottom of the curtain is parallel to the floor.
10. Replace the cover on the limit box and securely tighten the screw.
11. Determine whether to leave the curtain in the up or down position. Leaving the curtain in the down position will help to remove wrinkles from the vinyl.
12. Disconnect the temporary wiring and leave these instructions with the electrician or general contractor.
13. **Make sure Facility Electrician or Facility Manager has a copy of the wiring schematic that was furnished with the installation drawings.**

Permanent Wiring Motors for Installation

A qualified electrician should complete all permanent wiring.

Always refer to the electrical schematic furnished with the installation drawings at time of delivery of the product.

The following electrical schematics and information is for reference only.

1 HP 115VAC, 1PH, 60Hz, 20Amp Service

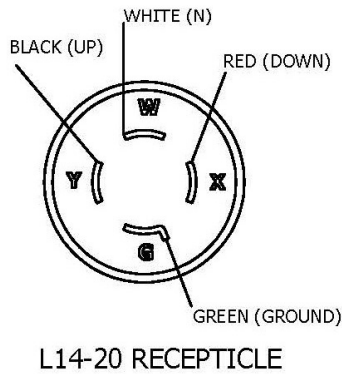
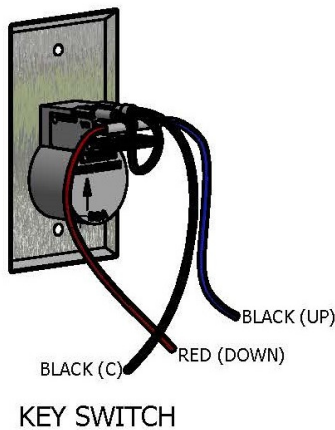
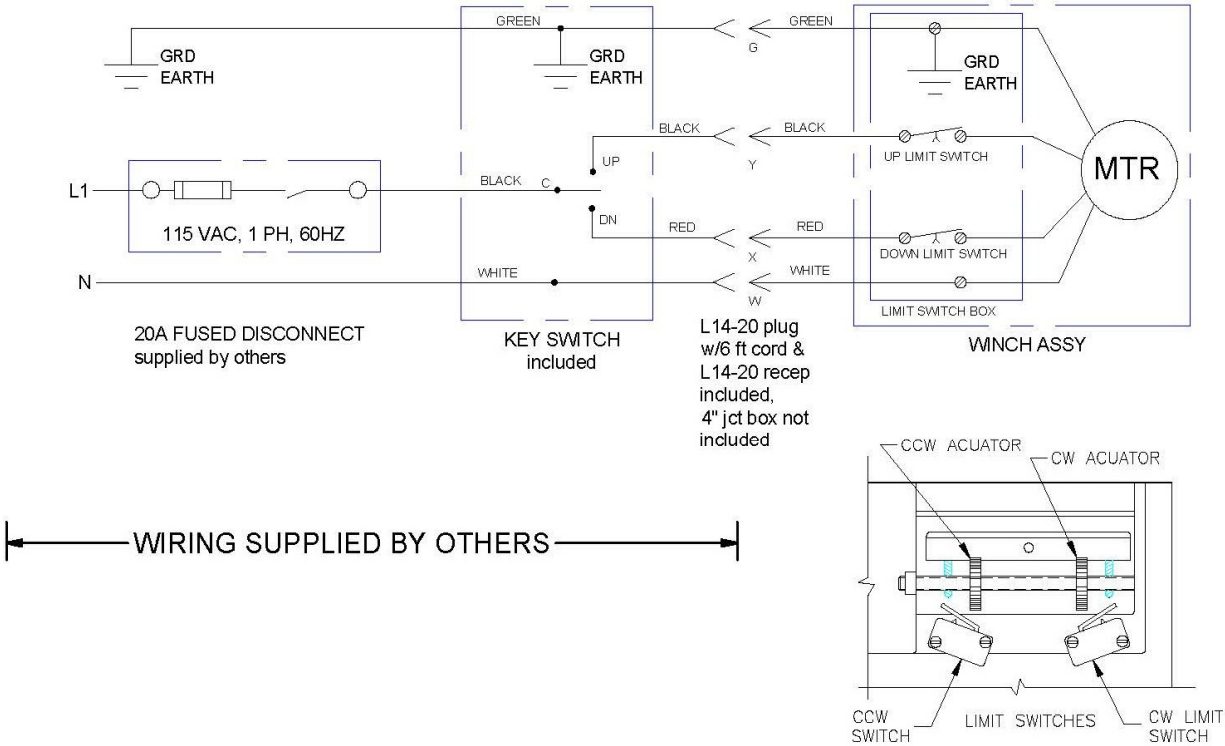

ELECTRICAL REQUIREMENTS

MINIMUM CIRCUIT REQUIREMENTS
-DEDICATED 115VAC, 1PH, 60HZ,
20 AMP SERVICE

MOTOR SPECIFICATION
-1 HP 115V, 1PH, 60HZ, 13 FLA
INSTANT REVERSING, THERMAL O/L

MINIMUM WIRE SIZE
(copper wire, 3% max voltage drop)

0-70 ft.....	12 ga.
70-110 ft.....	10 ga.
110-175 ft.....	8 ga.
175-280 ft.....	6 ga.
280-440 ft.....	4 ga.

3/4 HP 220VAC, 1PH, 50Hz, 10Amp Service

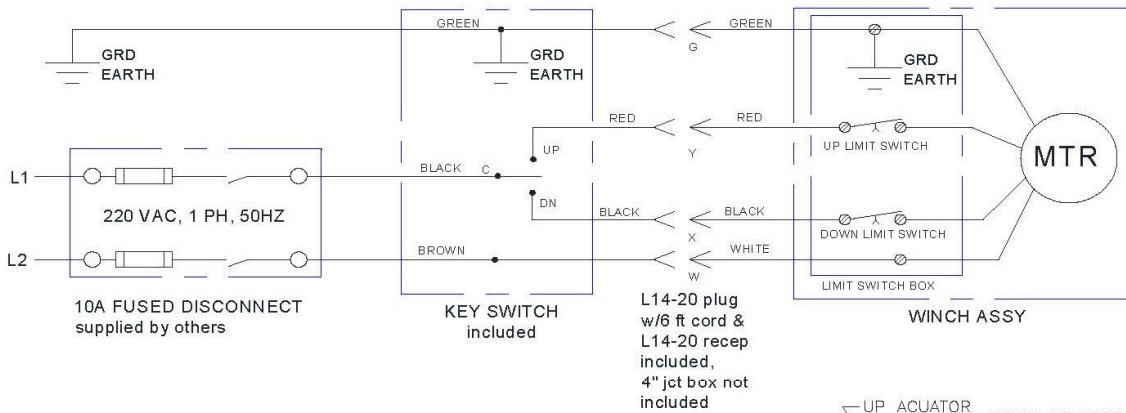

WIRING SUPPLIED BY OTHERS

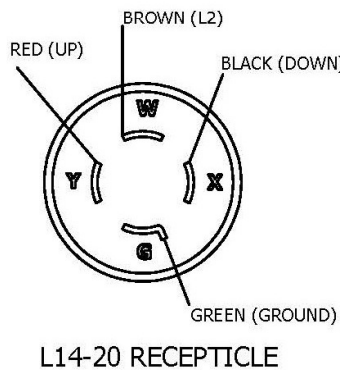
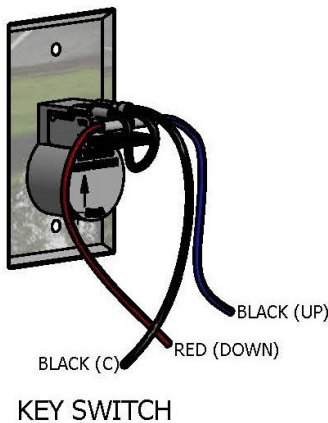
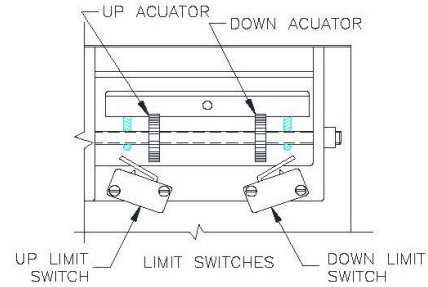

ELECTRICAL REQUIREMENTS

MINIMUM CIRCUIT REQUIREMENTS
-DEDICATED 220VAC, 1PH, 50HZ,
10 AMP SERVICE

MOTOR SPECIFICATION
-3/4HP 220V, 1PH, 50HZ, 5.5 FLA
INSTANT REVERSING, THERMAL O/L

MINIMUM WIRE SIZE
(copper wire, 3% max voltage drop)

0-200 ft.....	14 ga.	0-60M.....	2.0 mm2
200-310 ft.....	12 ga.	60-94M.....	3.0 mm2
310-500 ft.....	10 ga.	94-152M....	5.0 mm2
500-800 ft.....	8 ga.	152-243M....	8.0 mm2

3/4 HP 220VAC, 1PH, 60Hz, 10Amp Service

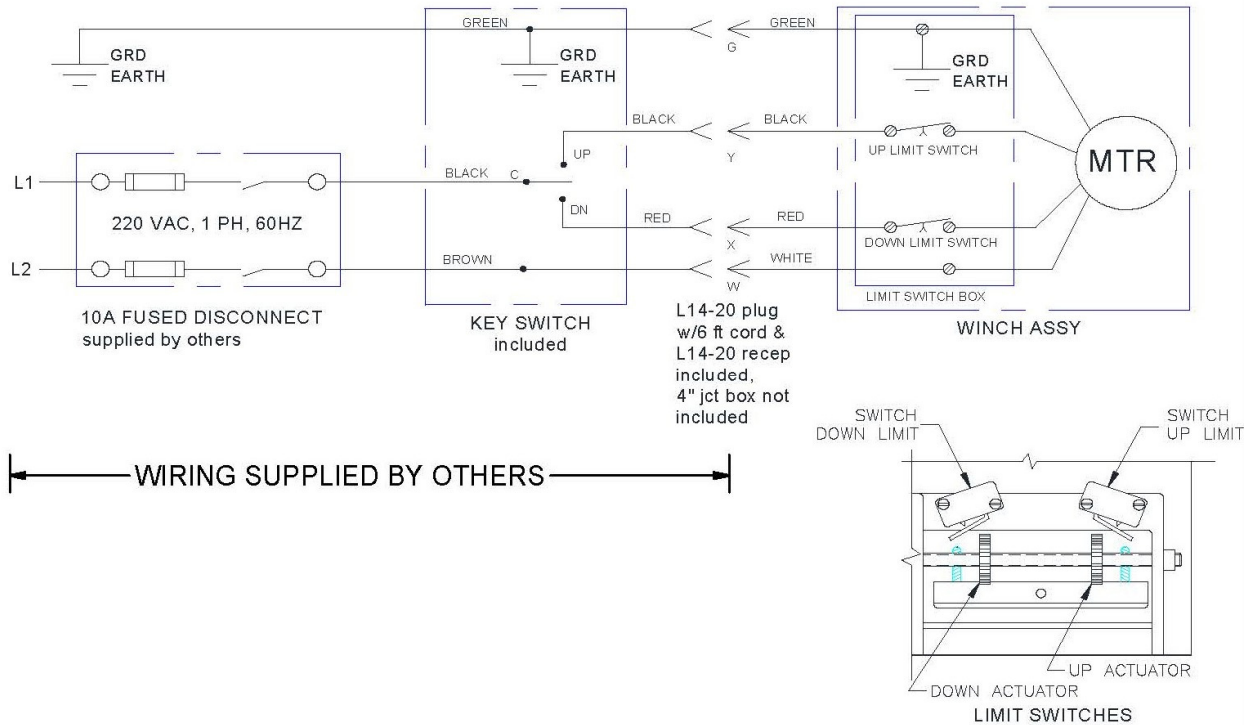

ELECTRICAL REQUIREMENTS

MINIMUM CIRCUIT REQUIREMENTS
 -DEDICATED 220VAC, 1PH, 60HZ,
 10 AMP SERVICE

MOTOR SPECIFICATION
 -3/4HP 220V, 1PH, 60HZ, 5.0 FLA
 INSTANT REVERSING, THERMAL O/L

MINIMUM WIRE SIZE
 (copper wire, 3% max voltage drop)
 0-210 ft..... 14 ga.
 211-340 ft..... 12 ga.
 341-540 ft..... 10 ga.
 541-870 ft..... 8 ga.

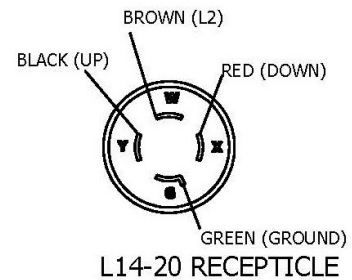
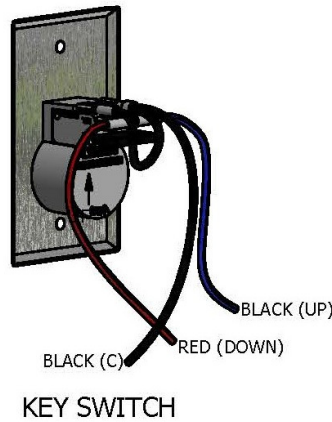

1 HP 208-230VAC, 3PH, 60Hz, 7Amp Service

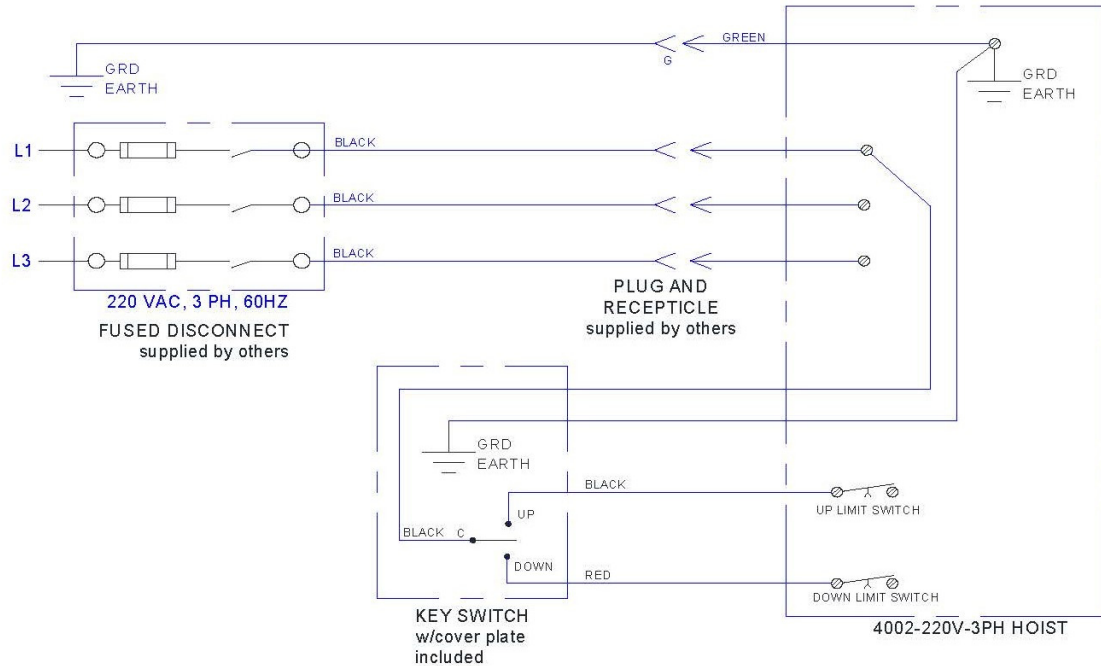

ELECTRICAL REQUIREMENTS

MINIMUM CIRCUIT REQUIREMENTS
 -DEDICATED 220VAC, 3PH, 60HZ,
 7 AMP SERVICE

MOTOR SPECIFICATION
 -1 HP 208-230V, 3PH, 60HZ, 3.7/3.4 FLA
 INSTANT REVERSING, THERMAL O/L

MINIMUM WIRE SIZE
 (copper wire, 3% max voltage drop)
 0-320 ft.....14 ga.
 321-500 ft.....12 ga.
 501-800 ft.....10 ga.

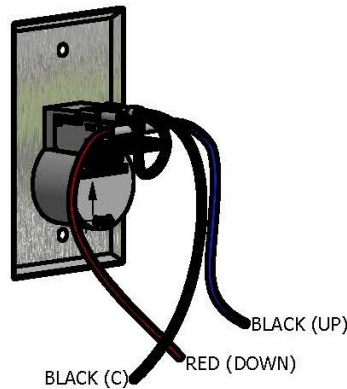

KEY SWITCH

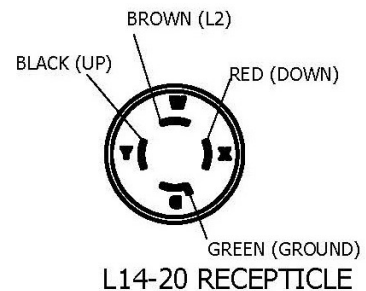
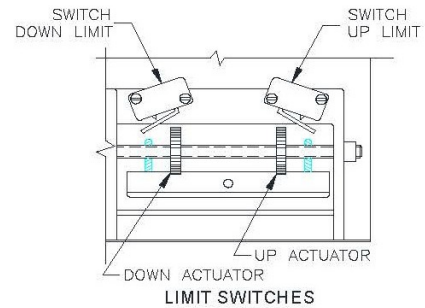

L14-20 RECEPTACLE

3/4 HP 240VAC, 1PH, 50Hz, 5Amp Service

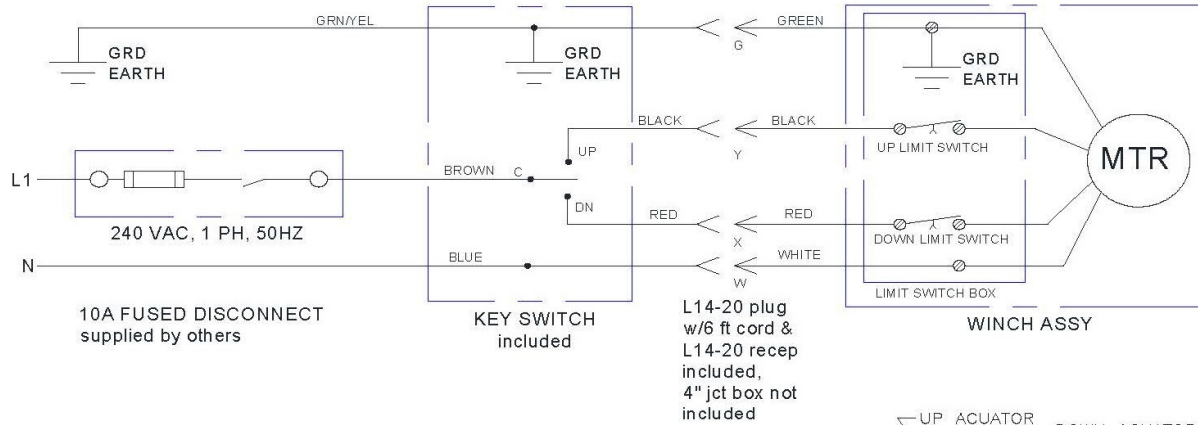

WIRING SUPPLIED BY OTHERS

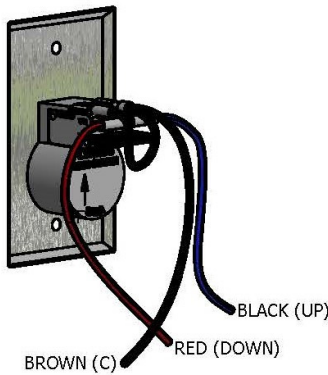
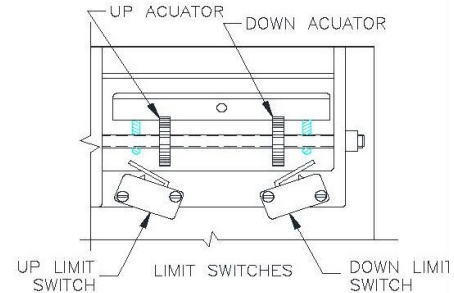

KEY SWITCH

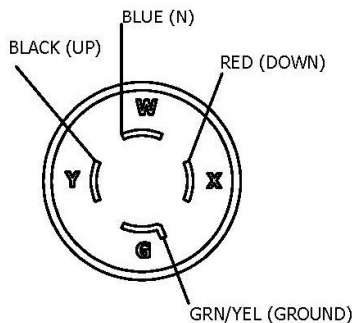

L14-20 RECEPTICLE

ELECTRICAL REQUIREMENTS

MINIMUM CIRCUIT REQUIREMENTS
 -DEDICATED 240VAC, 1PH, 50HZ,
 10 AMP SERVICE

MOTOR SPECIFICATION
 -3/4HP 240V, 1PH, 50HZ, 5.0 FLA
 INSTANT REVERSING, THERMAL O/L

MINIMUM WIRE SIZE
 (copper wire, 3% max voltage drop)

0-210 ft.....	14 ga.	0-64M.....	2.0 mm ²
211-340 ft.....	12 ga.	64-104M.....	3.0 mm ²
341-540 ft.....	10 ga.	104-165M.....	5.0 mm ²
541-870 ft.....	8 ga.	165-265M.....	8.0 mm ²



Fold Up Divider Curtain



PLEASE DO NOT ATTEMPT TO OPERATE THIS EQUIPMENT BEFORE READING THE FOLLOWING INFORMATION!!!

MODEL #4020 FOLD UP DIVIDER CURTAIN

PRODUCT OVERVIEW

The following information is designed to assist you with the operation and maintenance of your Model #4020 Fold Up Divider Curtain. We recommend that you carefully read this literature to become familiar with your new divider curtain, then develop an operation and maintenance program for the designated operator of the curtain.

⚠ CAUTION

Only trained and authorized personnel should operate this equipment.

Operation by untrained or unauthorized personnel may result in damage to the curtain structure and/or injury to anyone near the curtain.

This curtain has been manufactured with safety in mind, but even the safest equipment can be damaged or cause damage to a person or persons when operated by unauthorized or untrained users.

⚠ WARNING

BEFORE OPERATING DIVIDER CURTAIN MAKE SURE THE AREA AROUND AND UNDER THE CURTAIN IS CLEAR OF OBSTRUCTIONS, EQUIPMENT, AND PEOPLE. MAKE CERTAIN NO PERSONS ARE NEAR THE CURTAIN DURING OPERATION. FAILURE TO FOLLOW THIS PROCEDURE COULD RESULT IN EQUIPMENT DAMAGE AND/OR SERIOUS PERSONAL INJURY

701955081

- Tremendous force is created when this curtain is in motion.
- Only authorized personnel may operate curtain.
- Care must be taken to make sure the curtain and areas above and below the curtain are free and clear of any obstructions.
- Do not stand directly below the curtain when raising or lowering.
- Never swing or sway curtain.
- Structure and motor units were designed to lift the weight of the curtain only.
- Never hang from sides or bottom of curtain during operation or when curtain is in the lowered position.
- Never attach or place foreign objects on the curtain.



Fold Up Divider Curtain



OPERATION OF THE MODEL #4020 FOLD UP DIVIDER CURTAIN:

1. The key switch used to control the up/down motion of this curtain must be flush mounted on a wall that gives the operator a clear and full view of the curtain. Never operate the curtain if conditions do not allow for a clear and full view of the curtain.

▲ CAUTION

Operator must keep the curtain in view at all times during operation.

Failure to watch the curtain in motion may result in damage to the curtain structure and/or injury to anyone near the curtain.

2. The curtain may be raised or lowered by turning the key to the appropriate “Up” or “Down” position, as indicated on the switch cover plate.
3. The key that operates the curtain must remain in the possession of the authorized operator.

NEVER LEAVE THE KEY UNATTENDED IN THE KEY SWITCH

4. The motor that controls the movement of the curtain has been programmed to stop the curtain at a predetermined full “up” and full “down” position. Should the curtain stop before it reaches these predetermined positions the motor may have over heated and need to cool off. Allow the divider to rest for approximately 20 minutes and try to run again. If the divider still does not run contact your dealer or installation company immediately.

This divider curtain should be lowered to its full down position periodically to allow the vinyl to naturally stretch and remove any minor wrinkles caused from normal operation. It is recommended that the divider curtain be extended to the full down position and left in the down position for a period of 24 to 48 hours at least twice monthly.

This divider curtain has been custom manufactured according to the Owner’s/Architect’s specifications. When operated and maintained with proper care, this curtain should provide years of safe, trouble-free service.



Fold Up Divider Curtain



MAINTENANCE INFORMATION – PLEASE RETAIN FOR FUTURE REFERENCE!!!

MODEL #4020 FOLD UP DIVIDER CURTAIN

MAINTENANCE OVERVIEW

!!!ALWAYS DISCONNECT POWER SOURCE BEFORE PERFORMING ANY MAINTENANCE CHECK OR OPERATION ON THIS EQUIPMENT!!!

STRUCTURE:

We recommend a yearly inspection (or more frequently depending on usage) of the nuts and bolts, checking for tightness

MOTOR(S):

The motor that operates your divider curtain does not normally require any maintenance. We do recommend however, that the limit switches be checked on a regular basis to ensure the settings are accurate.

The motor should be inspected periodically for any leaks, loose drive couplings, etc.

⚠ WARNING
<p>When removing the motor or servicing the motor that requires disconnecting the drive shaft, first lower the curtain to the full down position. If the curtain cannot be lowered to the full down position, tie the folded curtain to the top batten in several places to prevent the curtain from moving.</p> <p>Failure to lower the curtain or secure the folded curtain to the top batten could result in the curtain unfolding uncontrollably when the motor is removed or the drive shaft is disconnected resulting in damage to the curtain and/or serious injury to anyone near or under the curtain.</p>

LIFT CABLES

Inspect cables for wear, fraying, etc.

CURTAIN VINYL:

The curtain vinyl should be checked on a regular basis for rips or tears. Should the vinyl become ripped or torn, it must be repaired or replaced. Contact your dealer or installation company for information on repair or replacement of the vinyl.

DO NOT operate the curtain if the vinyl is ripped or torn, as it could snag on the carrier assemblies.

The vinyl should be cleaned with a damp cloth. A cloth dampened with water will be adequate for most conditions, however, for heavier dirt or spots, a specific vinyl cleaner can be used.

This Model #4020 Fold Up Divider Curtain has been custom manufactured according to the Owner's/Architect's specifications. When operated and maintained with proper care, this curtain should provide years of safe, trouble free service.



Fold Up Divider Curtain



ATTENTION: MAINTENANCE DEPARTMENT

To confirm that you have received maintenance and warranty information, and to better serve you if you contact us, please fill out the following information and fax or mail to the address below.

Please refer to the facility name and/or the installation company below when you contact Performance Sports Systems, and include it on any correspondence.

I have received the maintenance and warranty information provided by Performance Sports Systems on the Fold Up Curtain.

Facility/School Name: _____

Installation Date: _____ Installed by: _____

Maintenance Dept. Contact: _____

Signature: _____ Date: _____

Fax to: 1-317-774-9841

Attn: Customer Service

Or

Mail to:

Customer Service

9200 E. 146th St., Ste. A

Noblesville, IN 46060

800-848-8034



Fold Up Divider Curtain



Maintenance Check Sheet

Date: _____

Unit: _____

Unit Supports / Brackets / Hinges

- Tubes; dents, stress spots, etc. OK Repair Replace
- Bolts; loose, deformed, etc. OK Repair Replace
- Brackets/Hinges; bent, not rotating, etc. OK Repair Replace

Winch/Cable/Chains

- Winch; binding, loose, etc. OK Repair Replace
- Cable; fraying OK Repair Replace
- Chains; deforming, broken/bent links OK Repair Replace
- Hardware; Quick links OK Repair Replace

Curtain Fabric

- Vinyl; torn, missing eyelets OK Repair Replace
- Mesh; torn, missing eyelets OK Repair Replace



Gared Holdings, LLC

Performance Sports Systems
9200 E. 146th Street
Noblesville, IN 46060

800-848-8034
www.perfsports.com

Gared Sports
9200 E. 146th Street
Noblesville, IN 46060

800-325-2682
www.garedsports.com