

**NOTES:**

- Designed for competition or recreational applications that require easy removal from floor sleeves when not in use.
- 6617 Uprights shall have an adjustable, protective rubber foot on the bottom and shall have a rope guide at the top for attaching the net. A rope clasp on the post allows quick net tensioning. The uprights shall be powder coated white.
- 6620 Net shall be 21' in length and 2'-6" tall. The netting shall be constructed of a durable 3/4" nylon mesh with vinyl borders.
- 6650 Floor Sleeves shall be 10 1/4" in length and constructed of heavy-gauge, 1 3/4" square steel tubing. Sleeves shall be set in grout at a dimension of 12" below finished floor.
- 6430 Floor Covers shall be swivel type, brass plated steel. Cover plate shall have a molded plastic recessed mounting flange, cork gasket, and 6 3/16" diameter cover. Molded plastic recessed mounting flange shall be 6 1/2" in diameter.

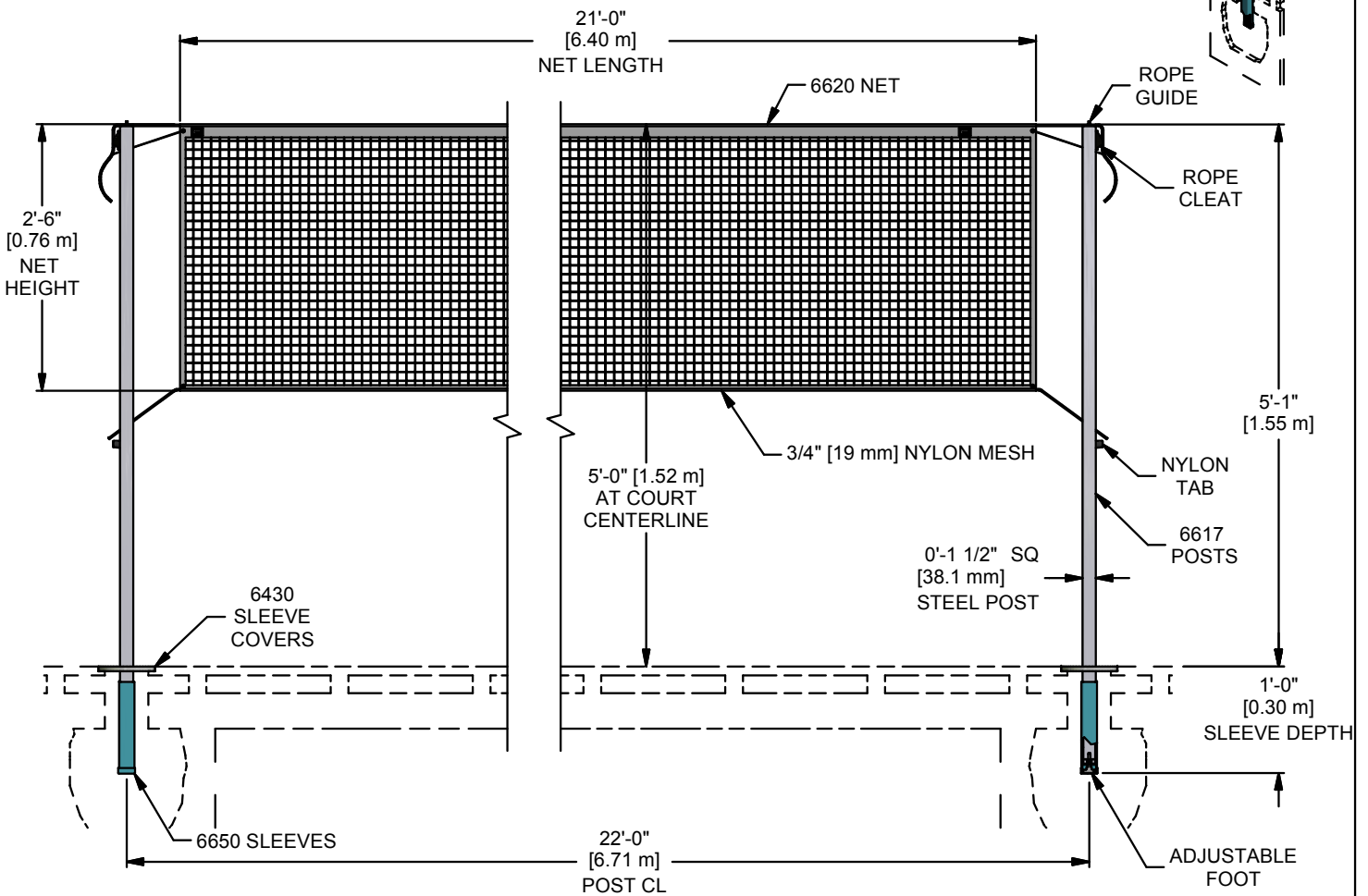

A	WDC	06-26-20
REV	BY	DATE

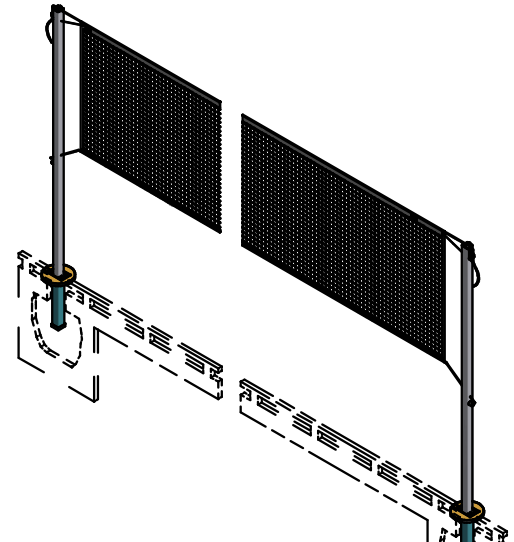

Gared Holdings, LLC  
9200 E. 146th St. Noblesville, IN 46060

THIS DOCUMENT CONTAINS TRADE SECRET AND OTHER MATERIALS WHICH ARE PROTECTED BY CONFIDENTIALITY NOTICE AND AGREEMENT AND BY COPYRIGHT. ANY USE OR COPYING OF THIS DOCUMENT EXCEPT AS AUTHORIZED BY GARED HOLDINGS, LLC IS STRICTLY PROHIBITED.

**BADMINTON SYSTEM, 1.5 SQ, 1 COURT**

DRAWN	CROSBY	DATE	6/26/2020	DATE ISSUED
APPROVED		DATE		

FILE LOC. Q:\Inventor Files\Specification Files\11\_Volleyball

SIZE	SCALE	SHT. NO.	PART NO.	REV
A		1 OF 2	6619	A



**MODEL 6619**  
**ONE-COURT SLEEVED BADMINTON SYSTEM**

**RECOMMENDED APPLICATION**

Designed for competition or recreational applications that require easy removal from floor sleeves when not in use.

**SPECIFICATIONS**

**POSTS**

The model 6619 Sleeved Badminton System shall consist of two square uprights constructed of 1-1/2" steel tubing, model 6617. The upright shall have an adjustable, protective rubber foot on the bottom and shall have a rope guide at the top for attaching the net. A rope clasp on the post allows quick net tensioning. The uprights shall be powder coated white.

**NET**

The model 6620 Badminton Net shall be 21' in length and 2'-6" tall. The netting shall be constructed of a durable 3/4" nylon mesh with vinyl boarders. The net is designed to connect to post set on 22'-0" centers.

**FLOOR SLEEVES**

The model 6650 Floor Sleeves shall be 10 1/4" in length and constructed of heavy-gauge, 1 3/4" square steel tubing. Sleeves shall be set in grout at a dimension of 12" below finished floor.

**FLOOR COVERS**

The model 6430 Floor Covers shall be swivel type, brass plated steel. Cover plate shall have a molded plastic recessed mounting flange, cork gasket, and 6 3/16" diameter cover. Molded plastic recessed mounting flange shall be 6 1/2" in diameter and have 3 holes in the ring (for screwing into the floor) that shall be completely concealed under the cover when in the closed position. Diameter of opening shall be 5 5/16".

**ACCESSORIES**

6618 CTR UPRIGHT ASSY, 1.5 SQ BADMINTON