

FULL WRAP WING BRACE

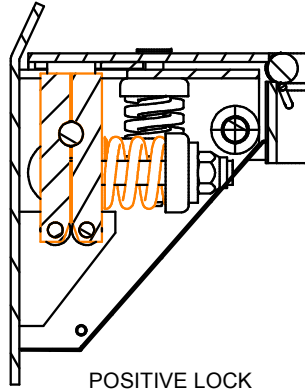

POSITIVE LOCK DETENT MECHANISM

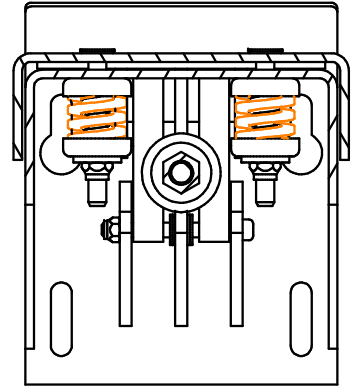

DUAL RETURN SPRINGS

NOTES:

OFFICIAL ORANGE POWDER COAT FINISH.

GOAL IS SUPPLIED WITH ANTI-WHIP NYLON NET, TIE CORD AND 3/8-16 MOUNTING HARDWARE.

GOAL IS FACTORY SET TO BREAKAWAY AT A 180-200 lb [82-91 kg] FORCE AND AUTOMATICALLY RETURNS WHEN LOAD IS RELEASE.

26 lbs [11.8 kg] SHIPPING WEIGHT.

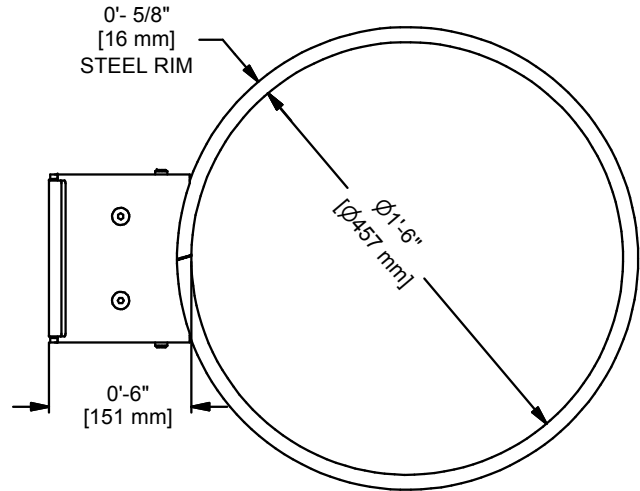

0'- 5/8"
[16 mm]
STEEL RIM

Ø1'-6"
[Ø157 mm]

0'-6"
[151 mm]

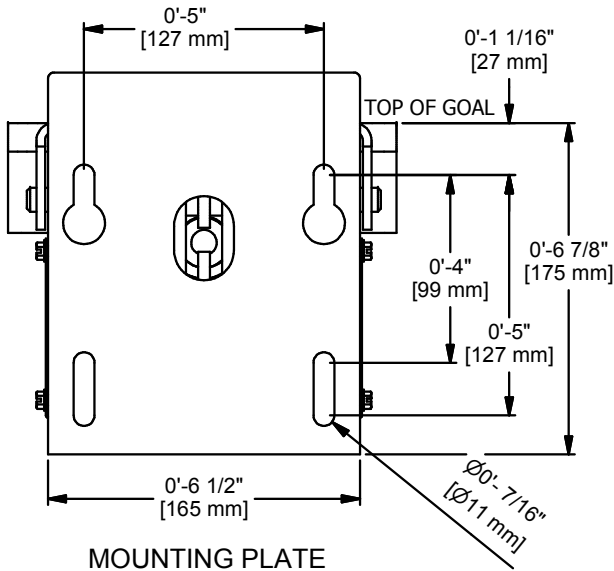

MOUNTING PLATE

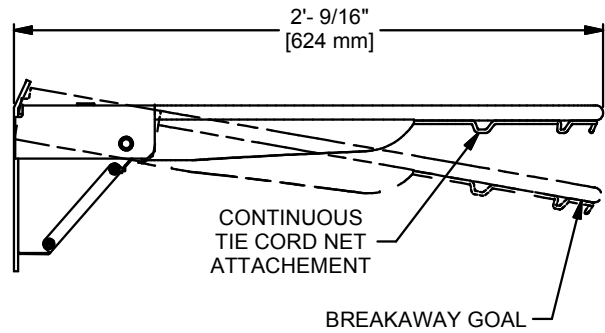

CONTINUOUS TIE CORD NET ATTACHMENT

BREAKAWAY GOAL

| | | |
|-----|-----|----------|
| D | WDC | 10-03-19 |
| REV | BY | DATE |



Gared Holdings, LLC
9200 E. 146th St. Noblesville, IN 46060

THIS DOCUMENT CONTAINS TRADE SECRET AND OTHER MATERIALS WHICH ARE PROTECTED BY CONFIDENTIALITY NOTICE AND AGREEMENT AND BY COPYRIGHT. ANY USE OR COPYING OF THIS DOCUMENT EXCEPT AS AUTHORIZED BY GARED HOLDINGS, LLC IS STRICTLY PROHIBITED.

SNAP BACK PRO ARENA GOAL

| | | | | |
|----------|--------|------|-----------|-------------|
| DRAWN | CROSBY | DATE | 10/3/2019 | DATE ISSUED |
| APPROVED | | DATE | | |

FILE LOC. Q:\Inventor Files\Specification Files\08_Goals

| | | | | |
|------|-------|----------|----------|-----|
| SIZE | SCALE | SHT. NO. | PART NO. | REV |
| A | | 1 OF 2 | SNAPA | D |



MODEL SNAPA

(20123T-A)

SNAP BACK BREAK-AWAY GOAL

The SNAPA goal shall be constructed with a completely enclosed positive lock, which holds the rim in solid playing position and automatically returns to playing position. Goal shall be factory set to break away at 180-200 lbs [82-91 Kg] force. Goal can be field adjusted up to 230 lbs [104 Kg] force. Goal shall have an official sized 18" ring of 5/8" diameter steel designed for use with AWP tie cord net. Goal shall meet all professional, NCAA, and high school requirements.

Goal shall have a durable orange powder coated paint finish and come complete with nylon net and tie cord. Hole spacing shall be 5" horizontal x 4-1/4" to 5" vertical.

ACCESSORIES

BACKBOARDS

See Goal-Board Matrix specification sheet for board compatibility.