

REAR VIEW

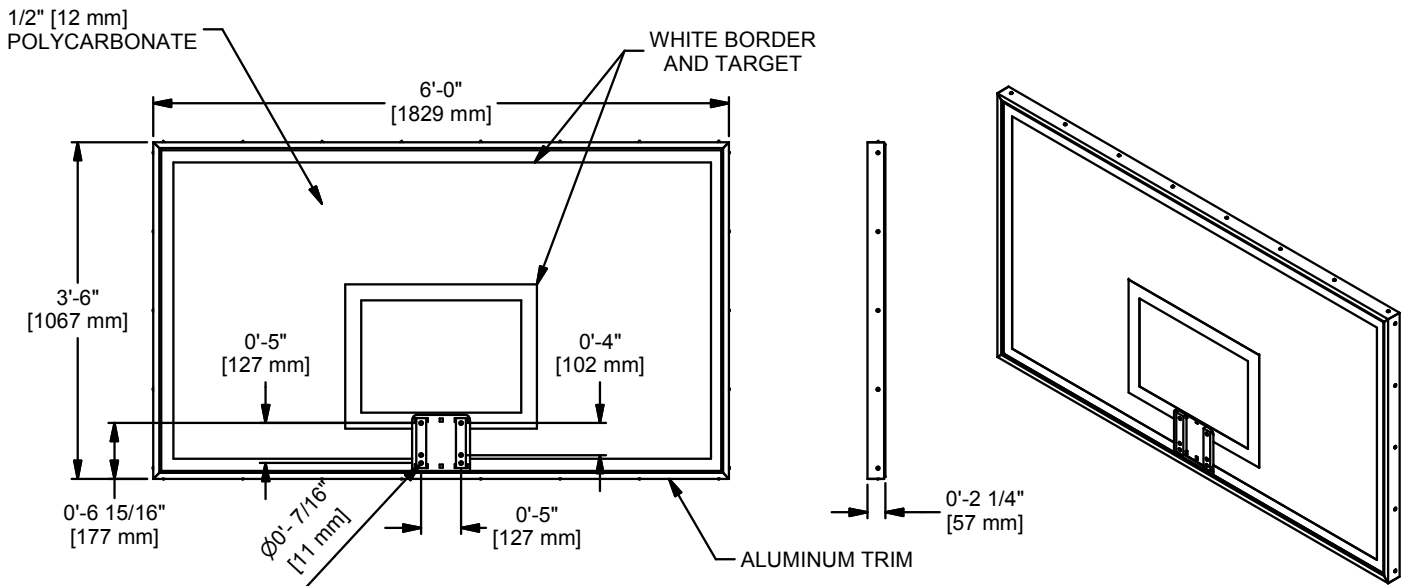

FRONT VIEW

A	WDC	03-21-18
REV	BY	DATE

PSS
PERFORMANCE
SPORTS SYSTEMS

GARED

Gared Holdings, LLC
9200 E. 146th St. Noblesville, IN 46060

THIS DOCUMENT CONTAINS TRADE SECRET AND OTHER MATERIALS WHICH ARE PROTECTED BY CONFIDENTIALITY NOTICE AND AGREEMENT AND BY COPYRIGHT. ANY USE OR COPYING OF THIS DOCUMENT EXCEPT AS AUTHORIZED BY GARED HOLDINGS, LLC IS STRICTLY PROHIBITED.

72" X 42" X 1/2" POLYCARBONATE BOARD

DRAWN	CROSBY	DATE	3/21/2018	DATE ISSUED
APPROVED		DATE		

FILE LOC. Q:\Inventor Files\Specification Files\07_Backboards

SIZE	SCALE	SHT. NO.	PART NO.	REV
A		1 OF 2	BB72P50	A



MODEL BB72P50

STEEL FRAME 72" X 42" RECTANGULAR POLYCARBONATE BACKBOARD

Backboard shall be constructed of a unitized welded tubular frame utilizing heavy wall $\frac{3}{4}$ " x 1.5" rectangular steel tubing. Frame shall include two vertical struts on 35 inch centers with holes for mounting to support structure. Design shall provide a reinforced goal mounting area to allow for direct mounting of goal, board, and structure. Direct mounting design shall have integral holes to allow permanent attachment of board to post and allow for goal replacement without removing the board.

Backboard shall be designed for use with residential adjustable units, gooseneck posts, and straight arm posts.

Backboard surface shall be constructed of 1/2" thick clear polycarbonate treated for UV protection, and abrasion resistance. Goal mounting holes shall be on standard 5" horizontal and 4" or 5" vertical centers.

Board frame shall be powder coated separately with a flat black weather resistant finish before being assembled.

GOALS

See Goal-Board Matrix specification sheet for goal compatibility.

Subject to design change and current manufacturing practices.