

FRONT VIEW

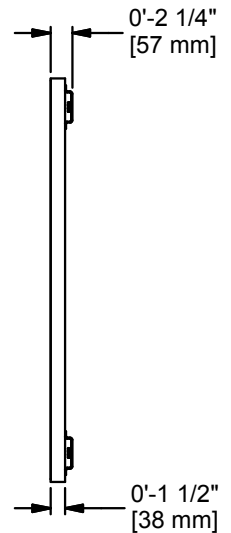

SIDE VIEW

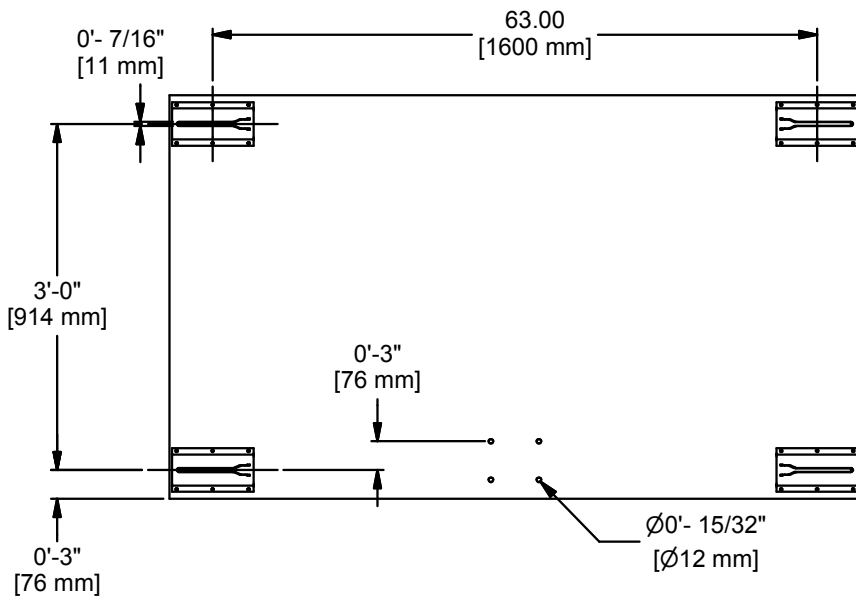

REAR VIEW

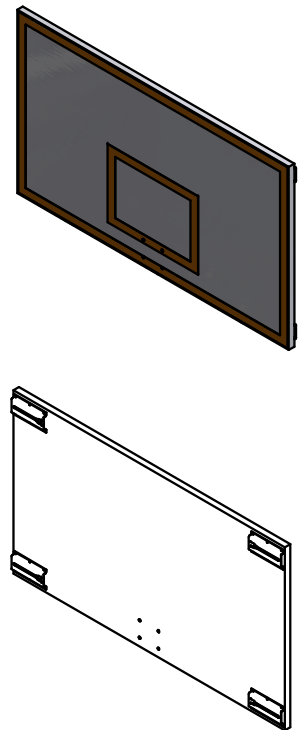

BACKBOARD THICKNESS IS 1-1/2" [38.1 mm], W/CORNER BRACKET 2-1/4" [57.2 mm]

MATERIAL IS WOOD

BOARD IS GLOSS WHITE WITH ORANGE TARGET AND BORDER.

G	JJC	11/15/17
F	WDC	08/24/16
REV	BY	DATE



Gared Holdings, LLC
9200 E. 146th St. Noblesville, IN 46060

THIS DOCUMENT CONTAINS TRADE SECRET AND OTHER MATERIALS WHICH ARE PROTECTED BY CONFIDENTIALITY NOTICE AND AGREEMENT AND BY COPYRIGHT. ANY USE OR COPYING OF THIS DOCUMENT EXCEPT AS AUTHORIZED BY GARED HOLDINGS, LLC IS STRICTLY PROHIBITED.

42" X 72" RECTANGULAR WOOD BACKBOARD

DRAWN CONNERLEY	DATE 5/2/2003	DATE ISSUED
APPROVED	DATE	
FILE LOC. Q:\Inventor Files\		
SIZE A	SCALE NONE	SHT. NO. 1 OF 2
PART NO. 1442B		REV G



MODEL 1442B

72" X 42" RECTANGULAR WOOD BACKBOARD WITH BORDER AND TARGET

The 1442B backboard shall be fabricated using 1 1/2" thick high-density fiberboard glued and cured under pressure with non-glare white face surfaces. Perimeter edges shall be eased. The front face, back face, and edges are laminated with a cured white polymer film. Film is composed of polyester acrylate for lasting durability. The cured polymer film contains no urea formaldehydes and is certified as a (LEEDS) green product. Orange border and target shall be silk-screened on face of bank with epoxy based ink for permanent markings.

Backboard shall have pre-drilled goal mounting holes on 5" horizontal and 4" vertical centers. Mounting brackets in each corner are used to mount backboard.

ACCESSORIES

GOALS

See Goal-Board Matrix specification sheet for goal compatibility.

Subject to design change and current manufacturing practices.