

**GARED**

[www.garedsports.com](http://www.garedsports.com)

Gared Holdings, LLC  
9200 East 146<sup>th</sup> Street, Suite A  
Noblesville, Indiana 46060  
800-325-2682

## ASSEMBLY & INSTALLATION INSTRUCTIONS

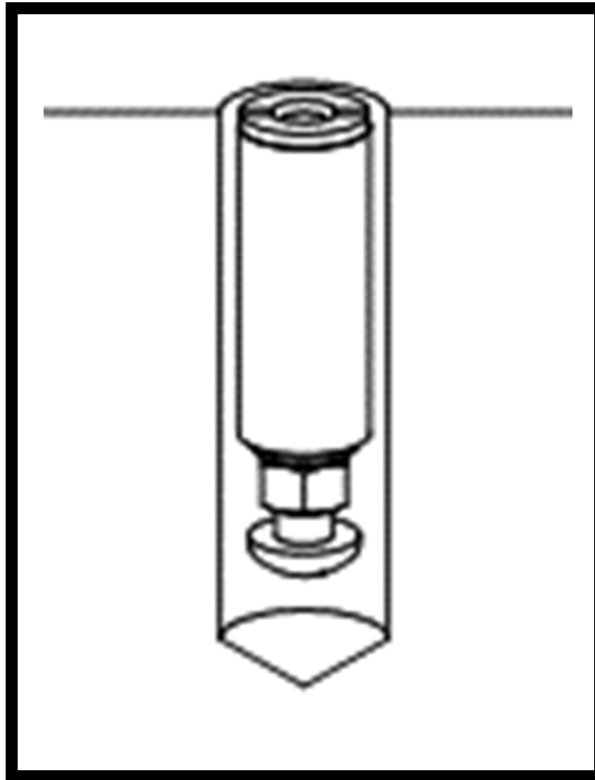

**STYLE "C" FLOOR PLATE**

**MODEL NUMBER**

**151651462**

Gared Holdings, LLC

9200 East 146<sup>th</sup> Street, Suite A

Noblesville, Indiana 46060

800-325-2682

**MODEL NUMBER**

**151651462**

**ASSEMBLY PARTS LIST**

KEY	DESCRIPTION	QTY
1	½" FLAT WASHER	1
2	½-13 X ¾ CAP SCREW	1
3	"C" ANCHOR ASSEMBLY	1
4	ANCHOR CEMENT BAG	1



**BEFORE YOU BEGIN INSTALLATION**

1. YOUR "C" PLATE COMES IN ONE PACKAGE. MAKE SURE YOU HAVE RECEIVED ALL THE PARTS LISTED ABOVE.
2. YOU WILL NEED THE FOLLOWING TOOLS AVAILABLE DURING INSTALLATION:  
HAMMER DRILL  
1-1/8" MASONRY BIT  
MIXING CONTAINER AND WATER  
SMALL VACUUM CLEANER, TIRE PUMP, OR BATTERY FILLER  
STIFF CIRCULAR BRUSH  
PUTTY KNIFE  
ABSORBENT RAG
3. READ ALL INSTRUCTIONS CAREFULLY BEFORE STARING INSTALLATION. CALL GARED WITH ANY QUESTIONS REGARDING PROPER INSTALLATION

**⚠ WARNING:** Prop 65 Warning for California Customers: This product can expose you to crystalline silica, which is known to the State of California to cause cancer and Portland cement, which is known to the State of California to cause birth defects or other reproductive harm.  
For more information go to [www.p65warnings.ca.gov](http://www.p65warnings.ca.gov)

**CAUTION:** IMPROPER INSTALLATION CAN CREATE A HAZARD WHEN FLOOR PLATES ARE USED WITH APPARATUS. FOLLOW DIRECTIONS CAREFULLY

**INSTALLATION INSTRUCTION:**

1. LOCATE AND MARK THE CENTER LOCATIONS OF THE FLOOR PLATES USING THE LAYOUT DIAGRAM PROVIDED WITH THE APPARATUS BEING INSTALLED. RE-CHECK ALL CENTER LOCATIONS FOR ACCURACY BEFORE INSTALLING THE ANCHOR.

Gared Holdings, LLC  
9200 East 146<sup>th</sup> Street, Suite A  
Noblesville, Indiana 46060  
800-325-2682

MODEL NUMBER  
151651462

INSTALLATION INSTRUCTION CONT:

2. USING THE ½" FLAT WASHER AS A TEMPLATE, MARK A CIRCLE CENTERED ON THE FLOOR ANCHOR LOCATION WITH A PENCIL OR FELT TIP MARKER. THIS WILL BE USED LATER AS A GUIDE FOR CENTERING THE FLOOR ANCHOR]
3. DRILL A HOLE IN THE MARKED LOCATION USING A HAMMER DRILL AND A 1-1/8" MASONRY BIT. DRILL THE HOLE TO A MINIMUM DEPTH OF 3-3/4". IF THE CONCRETE THICKNESS IS LESS THAN 3-3/4", CONTACT YOUR DEALER OR GARED CUSTOMER SERVICE FOR FURTHER ADVICE.

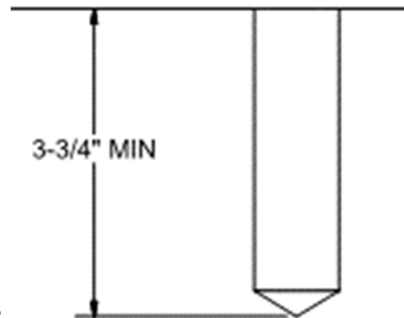

4. COMPLETELY REMOVE ALL DUST FROM THE HOLE BY SUCKING IT OUT WITH A VACUUM CLEANER OR BLOWING IT OUT WITH A TIRE PUMP OR BATTERY FILLER (COMPRESSED AIR).
5. FILL THE HOLE WITH WATER AND SCRUB SIDES AND BOTTOM WITH STIFF CIRCULAR BRUSH, SUCH AS A BOTTLE BRUSH. THIS STEP IS CRITICAL!
6. REMOVE EXCESS WATER AND ANY LOOSE PARTICLES WITH A RAG OR PAPER TOWEL. THE HOLE MUST BE CLEAN AND UNIFORMLY DAMP.
7. MEASURE ONE-PART WATER TO FIVE PARTS CEMENT BY VOLUME (PROVIDED) AND MIX TOGETHER IN CLEAN CONTAINER. MEASURE WATER TO CEMENT RATIO AS ACCURATELY AS POSSIBLE. MIX SHOULD REACH A FLOWABLE CONSISTENCY.



CAUTION:

**DO NOT** ADD SAND, GRAVEL, OR OTHER FOREIGN SUBSTANCES TO THE CEMENT, DOING SO WILL WEAKEN THE CEMENT.

**DO NOT** ADD TOO MUCH WATER, OR ATTEMPT TO "RE-TEMPER" CEMENT THAT HAS BEGUN TO CURE BY ADDING WATER. THIS WILL RESULT IN FAILURE OF THE CEMENT TO ACHIEVE PROPER STRENGTH.

Gared Holdings, LLC  
9200 East 146<sup>th</sup> Street, Suite A  
Noblesville, Indiana 46060  
800-325-2682

**MODEL NUMBER**  
**151651462**

INSTALLATION INSTRUCTION CONT:

8. PLACE THE FLAT WASHER ON THE 3/4" CAP SCREW, INSERT THE CAP SCREW INTO THE ANCHOR AND TIGHTEN FINGER TIGHT.
9. POUR CEMENT MIXTURE INTO THE CLEANED DAMP HOLE UNTIL IT IS APPROXIMATELY 3/4 FULL.

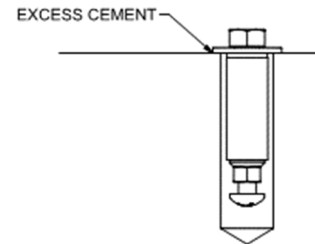

10. WET THE KNURLED (ROUGH) SURFACE OF THE ANCHOR BODY WITH WATER, DO NOT ALLOW WATER TO GET INTO THE WORKINGS OF THE ANCHOR ASSEMBLY. INSERT THE ANCHOR TUBE INTO THE HOLE, KEEPING THE WASHER CENTERED AROUND THE PRE-MARKED CIRCLE. LOWER IT UNTIL THE WASHER IS FLUSH WITH THE FLOOR. EXCESS CEMENT SHOULD FLOW OUT AROUND THE WASHER. IF THIS DOES NOT HAPPEN, THE ANCHOR TUBE BODY SHOULD BE REMOVED, MORE CEMENT ADDED, AND RE-INSERTED INTO HOLE. SCRAPE THE EXCESS CEMENT MIXTURE WITH A PUTTY KNIFE OR SCRAPER.
11. AFTER 15 MINUTES, THE CEMENT AND FLOOR PLATE ARE INITIALLY SET. CAREFULLY REMOVE THE CAP SCREW AND WASHER FROM THE ANCHOR. USING PUTTY KNIFE OR SCRAPER, SMOOTH OUT THE CEMENT AROUND THE ANCHOR FOR AN EVEN FINISH.
12. ALLOW 12 HOURS TO FULLY CURE. AFTER 12 HOURS, THE APPARATUS MAY BE SET UP AND USED WITH FLOOR PLATE
13. WHEN INSTALLING THE APPARATUS TO THE FLOOR PLATE, INSERT THE FASTENERS FINGER TIGHT ONLY. NO TOOLS SHOULD BE REQUIRED FOR THIS OPERATION. AFTER THE FASTENER HAS BEEN TIGHTENED FINGER TIGHT, LOOSEN ONLY ENOUGH TO ALLOW PROPER ALIGNMENT BETWEEN APPARATUS ATTACHING BRACKET(S) AND FASTENER.

USE OF YOUR "C" PLATE

1. THIS FLOOR ANCHOR IS INTENDED FOR USE IN CONCRETE FLOORS. IF THERE IS ANY QUESTION ABOUT THE APPROPRIATE FLOOR PLATE FOR YOUR FLOOR SURFACE, CONTACT GARED FOR ASSISTANCE BEFORE INSTALLING.
2. CLEAN AND INSPECT FLOOR PLATES REGULARLY. ENSURE THAT THREADS ARE ENGAGING PROPERLY AND THERE IS NO BREAKDOWN OF CEMENT. PROPERLY INSTALLED, THIS FLOOR PLATE IS DESIGNED TO WITHSTAND ANY LOAD APPLIED BY THE APPARATUS.
3. IF THERE IS ANY DOUBT AS TO THE INTEGRITY OF THE FLOOR PLATE, **DO NOT USE IT**. CONTACT A PROFESSIONAL INSTALLER OR GARED FOR EVALUATION.

Gared Holdings, LLC  
9200 East 146<sup>th</sup> Street, Suite A  
Noblesville, Indiana 46060  
800-325-2682

**MODEL NUMBER**  
**151651462**

KEY	REPL KIT PART # 151651422
1	CHROME REMOVABLE CAP
2	CHROME FLOOR PLATE PLUG
3	EXTERNAL E-RING
4	FLOOR PLUG SPRING
5	FLOOR PLATE ANCHOR SCREW
6	3/8" HEX NUT
7	3/8" X 3/4" HEX SOCKET SCREW

