

GARED

www.garedsports.com

Gared Holdings, LLC
9200 East 146th Street, Suite A
Noblesville, Indiana 46060
800-325-2682

ASSEMBLY & INSTALLATION INSTRUCTIONS

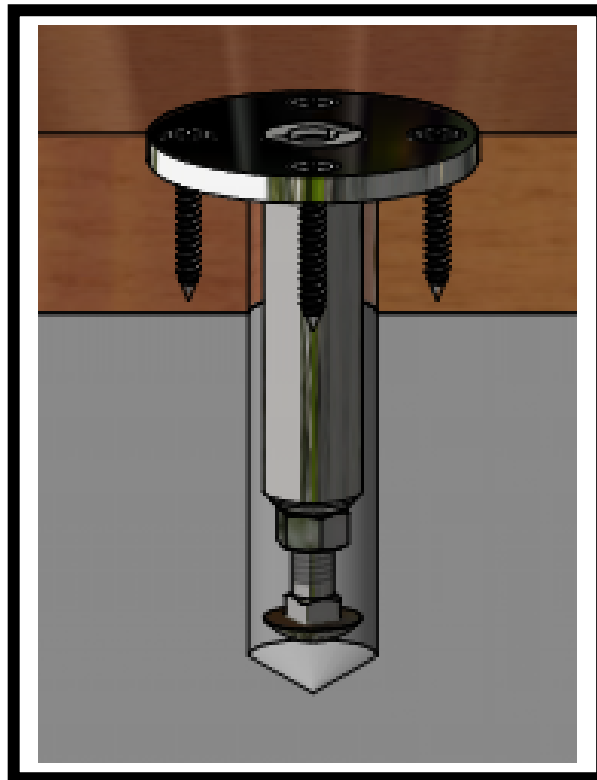

STYLE "BX" FLOOR PLATE

MODEL NUMBER

151651460

Gared Holdings, LLC

9200 East 146th Street, Suite A

Noblesville, Indiana 46060

800-325-2682

MODEL NUMBER

151651460

ASSEMBLY PARTS LIST

KEY	DESCRIPTION	QTY
1	¼ X 1-1/2" TAP SCREW	4
2	½-13 X ¾ CAP SCREW	1
3	"BX" PLATE ASSEMBLY	1
4	ANCHOR CEMENT BAG	1

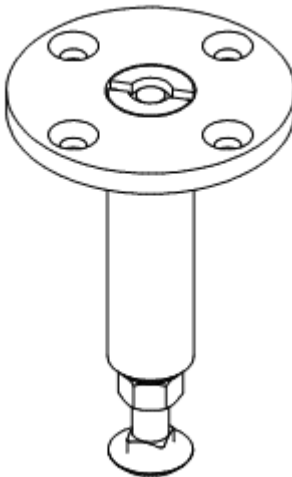
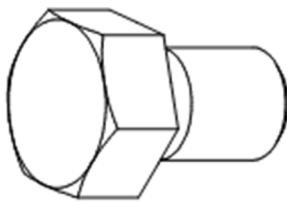

BEFORE YOU BEGIN INSTALLATION

1. YOUR "BX" PLATE COMES IN ONE PACKAGE. MAKE SURE YOU HAVE RECEIVED ALL THE PARTS LISTED ABOVE. THE CAP SCREW IS USED TO AID IN CORRECT INSTALLATION
2. YOU WILL NEED THE FOLLOWING TOOLS AVAILABLE DURING INSTALLATION:
HAMMER DRILL
1-1/8" MASONRY BIT
REGULAR DRILL W/ 1-1/8" WOOD DRILL BIT
ONE 5/32" DRILL BIT
ROUTER
SCREWDRIVER WITH WIDE BLADE
MIXING CONTAINER AND WATER
SMALL VACUUM CLEANER, TIRE PUMP, OR BATTERY FILLER
STIFF CIRCULAR BRUSH
PUTTY KNIFE
ABSORBENT RAG
3. READ ALL INSTRUCTIONS CAREFULLY BEFORE STARING INSTALLATION. CALL GARED WITH ANY QUESTIONS REGARDING PROPER INSTALLATION

Prop 65 Warning for California Customers

⚠ WARNING: This product can expose you to crystalline silica, which is known to the State of California to cause cancer and Portland cement, which is known to the State of California to cause birth defects or other reproductive harm.
For more information go to www.p65warnings.ca.gov

CAUTION: IMPROPER INSTALLATION CAN CREATE A HAZARD WHEN FLOOR PLATES ARE USED WITH APPARATUS. FOLLOW DIRECTIONS CAREFULLY

INSTALLATION INSTRUCTION:

1. LOCATE AND MARK THE CENTER LOCATIONS OF THE FLOOR PLATES USING THE LAYOUT DIAGRAM PROVIDED WITH THE APPARATUS BEING INSTALLED. RE-CHECK ALL CENTER LOCATIONS FOR ACCURACY BEFORE INSTALLING THESE PLATES

Gared Holdings, LLC

9200 East 146th Street, Suite A

Noblesville, Indiana 46060

800-325-2682

MODEL NUMBER

151651460

INSTALLATION INSTRUCTION CONT:

2. USING THE 1-1/8" WOOD DRILL BIT, DRILL A HOLE IN TO THE WOOD FLOOR AND SUB FLOOR TO THE CONCRETE SURFACE

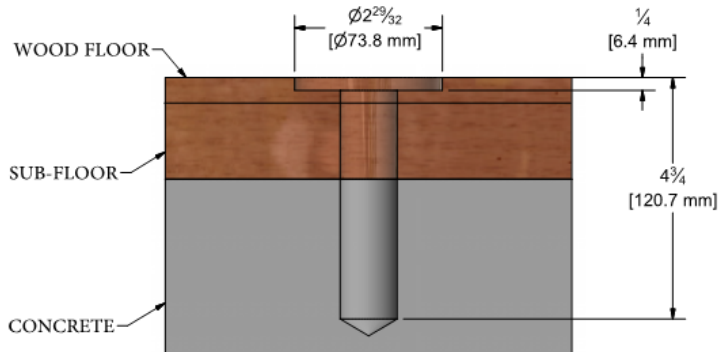

3. NEXT, USE THE 1-1/8" MASONRY BIT AND DRILL TO A MINIMUM DEPTH OF 4-3/4" AS SHOWN IN THE FIGURE

4. MAKE A TEMPLATE USING A PIECE OF MASONITE OR THICK PLASTIC. MAKE A HOLE IN THE TEMPLATE MATERIAL SO THAT WHEN THE ROUTER IS USED WITH IT, THE COUNTERBORED DIAMETER IS 2-29/32". USE A SCRAP BOARD TO PRACTICE, AND FOR CHECKING THE FINISHED HOLE SIZE BEFORE ATTEMPTING THIS ON YOUR FLOOR.

5. CREATE A COUNTERBORED HOLE 2-29/32" DIAMETER AND 1/4" DEEP CENTERED ON THE 1-1/8" DIAMETER HOLE PREVIOUSLY DRILLED INTO FLOOR.

WHEN MAKING THE COUNTERBORE, KEEP PRESSURE ON THE TEMPLATE AT ALL TIMES. THIS WILL KEEP THE TEMPLATE FROM SLIPPING, IT WILL ALSO HELP TO KEEP THE WOOD FLOOR FROM SPLINTERING AROUND THE HOLE. DO NOT SET THE DEPTH AT 1/4" FOR THE FIRST PASS ON THE ROUTING STEP. GRADUALLY WORK DOWN TO THE DEPTH AT WHICH THE FLOOR PLATE IS JUST FLUSH WITH THE SURFACE OF THE FLOOR. PLACE THE FLOOR PLATE INTO THE HOLE SEVERAL TIMES TO ENSURE THAT THE HOLE IS NOT MADE TOO DEEP. THE FLOOR PLATE MUST BE PERFECTLY FLUSH WITH THE TOP SURFACE OF THE FLOOR.

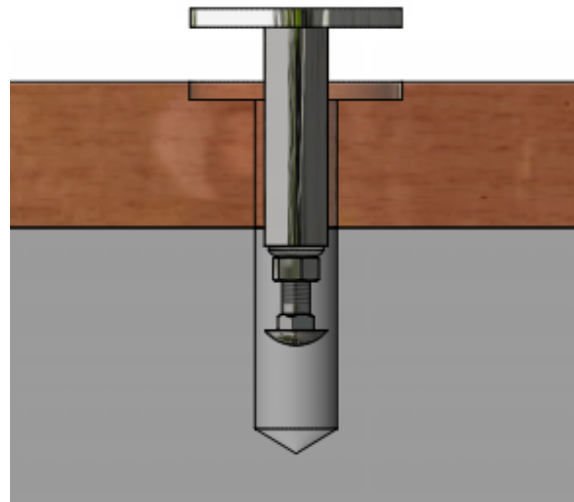

6. COMPLETELY REMOVE THE DUST FROM THE HOLE BY SUCKING IT OUT WITH A VACUUM CLEANER, OR BLOWING IT OUT WITH A TIRE PUMP OR BATTERY FILLER.

Gared Holdings, LLC
9200 East 146th Street, Suite A
Noblesville, Indiana 46060
800-325-2682

MODEL NUMBER
151651460

INSTALLATION INSTRUCTION CONT:

7. FILL THE HOLE WITH WATER AND SCRUB SIDES AND BOTTOM WITH STIFF CIRCULAR BRUSH, SUCH AS A BOTTLE BRUSH. THIS STEP IS CRITICAL!
8. REMOVE EXCESS WATER AND ANY LOOSE PARTICLES WITH A RAG OR PAPER TOWEL. THE HOLE MUST BE CLEAN AND UNIFORMLY DAMP.
9. MEASURE ONE-PART WATER TO FIVE PARTS CEMENT BY VOLUME (PROVIDED) AND MIX TOGETHER IN CLEAN CONTAINER. MEASURE WATER TO CEMENT RATIO AS ACCURATELY AS POSSIBLE. MIX SHOULD REACH A FLOWABLE CONSISTENCY.

CAUTION:

DO NOT ADD SAND, GRAVEL, OR OTHER FOREIGN SUBSTANCES TO THE CEMENT, DOING SO WILL WEAKEN THE CEMENT.

DO NOT ADD TOO MUCH WATER, OR ATTEMPT TO “RE-TEMPER” CEMENT THAT HAS BEGUN TO CURE BY ADDING WATER. THIS WILL RESULT IN FAILURE OF THE CEMENT TO ACHIEVE PROPER STRENGTH.

10. INSERT THE CAP SCREW INTO THE FLOOR PLATE UNTIL
11. POUR CEMENT MIXTURE INTO THE CLEANED DAMP HOLE UNTIL IT IS APPROXIMATELY $\frac{3}{4}$ FULL.
12. WET THE KNURLED (ROUGH) SURFACE OF THE FLOOR PLATE BODY WITH WATER, DO NOT ALLOW WATER TO GET INTO THE WORKINGS OF THE FLOOR PLATE ASSEMBLY. INSERT THE FLOOR PLATE ASSEMBLY INTO THE CEMENT FILLED HOLE. PRESS DOWN ON CAP SCREW UNTIL THE TOP PLATE IS PROPERLY SEATED IN THE COUNTERBORED HOLE. EXCESS CEMENT SHOULD FLOW OUT AROUND THE TOP OF THE PLATE. IF THIS DOES NOT HAPPEN, THE FLOOR PLATE BODY SHOULD BE REMOVED, MORE CEMENT ADDED, AND RE-INSERTED INTO HOLE. SCRAPE THE EXCESS CEMENT MIXTURE WITH A PUTTY KNIFE OR SCRAPER.

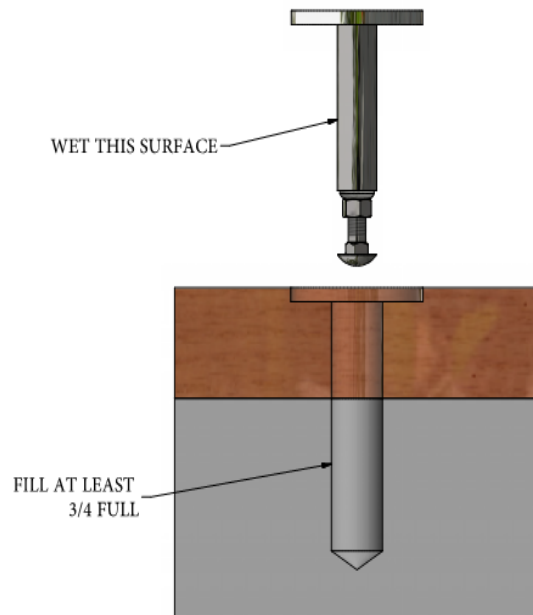

Gared Holdings, LLC
9200 East 146th Street, Suite A
Noblesville, Indiana 46060
800-325-2682

MODEL NUMBER
151651460

INSTALLATION INSTRUCTION CONT:

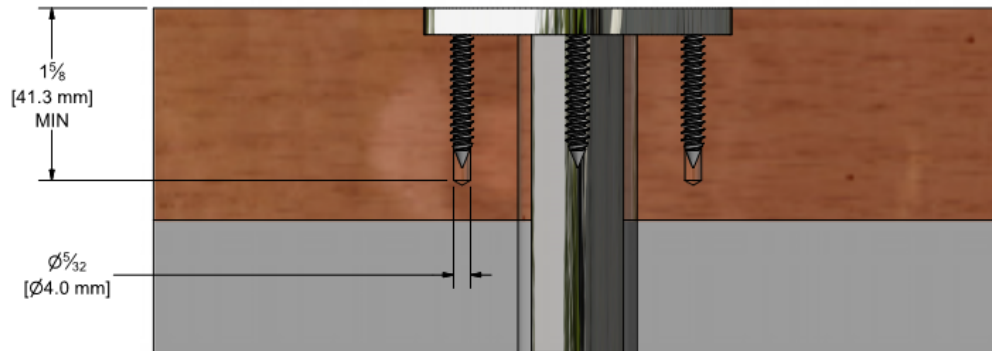

13. USING THE TOP OF THE FLOOR PLATE AS A GUIDE, CENTER THE 5/32" DRILL BIT IN EACH HOLE AND DRILL FOUR (4) HOLES IN THE WOOD FLOOR 1-5/8" DEEP FOR THE WOOD SCREWS AS SHOWN ABOVE. INSTALL THE WOOD SCREWS, MAKING SURE THAT THEY ARE STRAIGHT AND WELL SEATED IN THE COUNTERSINK OF THE TOP PLATE.
14. ALLOW TO CURE FOR AT LEAST 15 MINUTES. AFTER THIS TIME THE CEMENT IS INITIALLY SET. REMOVE THE CAP SCREW FROM THE TOP PLATE
15. ALLOW 12 HOURS TO FULLY CURE. AFTER 12 HOURS, THE APPARATUS MAY BE SET UP AND USED WITH FLOOR PLATE
16. WHEN INSTALLING THE APPARATUS TO THE FLOOR PLATE, INSERT THE EYE SCREWS FINGER TIGHT ONLY. NO TOOLS SHOULD BE REQUIRED FOR THIS OPERATION. AFTER THE EYE SCREW HAS BEEN TIGHTENED FINGER TIGHT, LOOSEN ONLY ENOUGH TO ALLOW PROPER ALIGNMENT BETWEEN APPARATUS ATTACHING BRACKET(S) AND EYEBOLT.

USE OF YOUR "BX" PLATE

1. THIS FLOOR PLATE IS INTENDED FOR USE IN FLOORS WITH MULTIPLE LAYERS OF WOOD INSTALLED DIRECTLY OVER CONCRETE. IT IS NOT INTENDED FOR USE WITH FLOATING FLOORS OR CONCRETE ONLY FLOORS. IF THERE IS ANY QUESTION ABOUT THE APPROPRIATE FLOOR PLATE FOR YOUR FLOOR SURFACE, CONTACT GARED FOR ASSISTANCE BEFORE INSTALLING.
2. CLEAN AND INSPECT FLOOR PLATES REGULARLY. ENSURE THAT THREADS ARE ENGAGING PROPERLY AND THERE IS NO BREAKDOWN OF CEMENT. PROPERLY INSTALLED THIS FLOOR PLATE IS DESIGNED TO WITHSTAND ANY LOAD APPLIED BY THE APPARATUS.
3. IF THERE IS ANY DOUBT AS TO THE INTEGRITY OF THE FLOOR PLATE, **DO NOT USE IT**. CONTACT A PROFESSIONAL INSTALLER OR GARED FOR EVALUATION.

Gared Holdings, LLC
 9200 East 146th Street, Suite A
 Noblesville, Indiana 46060
 800-325-2682

MODEL NUMBER
151651460

REPLACEMENT PARTS LIST

(ALL PARTS INCLUDED IN PART # 151651422)

KEY	PART NAME
1	REMOVABLE CAP
2	FLOOR PLATE PLUG
3	EXTERNAL E-RING
4	FLOOR PLATE SPRING (2X)
5	FLOOR PLATE ANCHOR SCREW
6	3/8" HEX NUT
7	3/8-16 X 1-1/2 CARRIAGE BOLT

