



**ADJUST-A-GOAL**  
**Models: 1131 and 1171**



**Installation, Operation and Maintenance Instructions**

.....  
**Please read all instructions before attempting installation or operation of these units**  
.....

**SAVE THESE INSTRUCTIONS FOR FUTURE USE**

# ***Table of Contents***

<b><u>Section</u></b>	<b><u>Page No.</u></b>
Introduction	1
Cautions and Warnings	2
Assembly and Setup	3-13
Electrical Installation	14
Operation	15
Maintenance	15
Accessories	16

## ***Introduction***

Thank you for your purchase of a basketball goal height adjuster. To ensure that our equipment will provide years of use to you, we are including this installation, operation, and maintenance guide. This guide will provide information on the proper assembly and installation methods, operating procedures, and preventative maintenance of your height adjuster.

It is recommended that an individual who has been properly trained perform assembly and set up of the goal height adjuster. No one under the age of 18 should attempt assembly or set up of the unit, unless properly supervised.

To prevent normal wear and tear from shortening the life of the height adjuster, preventative maintenance inspections and repairs should be performed at least once per year. If the height adjuster is subject to high or unusual usage, inspections should be scheduled to occur more frequently. If items are found to be nonconforming, replacements can be ordered from an authorized dealer. When contacting your dealer, please have information regarding the name of the project, and any applicable warranty information.

Please note that manufacturer assumes no responsibility for the building structure to support its products. It is the responsibility of the building designers to determine the correct structure size to support our products. We will provide your structural engineers with all required weight and loading information for the project in order for them to calculate the appropriate structure.



# HEIGHT ADJUSTER



Read and understand the following warnings to prevent possible personal injury and potential damage to the equipment during assembly, setup, and operation.

**⚠ DANGER**

DO NOT CLIMB ON GOAL, BANKBOARD OR BACKSTOP.

---

THIS UNIT IS DESIGNED FOR A SPECIFIC OPERATING WEIGHT AND THE ADDED WEIGHT COULD CAUSE DAMAGE AND/OR SERIOUS INJURY TO PERSONNEL.

2036-31-00

**⚠ CAUTION** MOVING PARTS! KEEP HANDS, ARMS, BODY CLEAR DURING OPERATION

124252798

**⚠ WARNING**

The 5/8" mast clamp U-bolt nuts **MUST** be torqued to a value of 94 to 130 Ft-Lbs. [128 to 176 Nm].

Failure to torque the U-bolt nuts to the specified value could allow the backboard to slip off the mast resulting in serious injury or death.

123951581

**⚠ WARNING**

Stop Bolts **MUST** be installed on each side of the mast clamp after final adjustment. See installation instructions.

Failure to install these bolts could allow the backboard to slip off the mast resulting in serious injury or death.

123951584

Before proceeding with assembly, **read all instructions and assembly procedures**. Make sure all parts have been received and are not damaged.

## INSTALLATION INSTRUCTIONS

### Tools Required:

- 7/16 wrench and socket
- 1/2 wrench and socket
- 9/16 wrench and socket
- Rubber Mallet
- 3/4 wrench and socket
- 15/16 wrench and socket
- 11/16 wrench and socket
- Ratchet corresponding to sockets
- 1/2" Torque wrench (150 ftlbs +)
- 3/8" Torque wrench (10 ftlbs +)

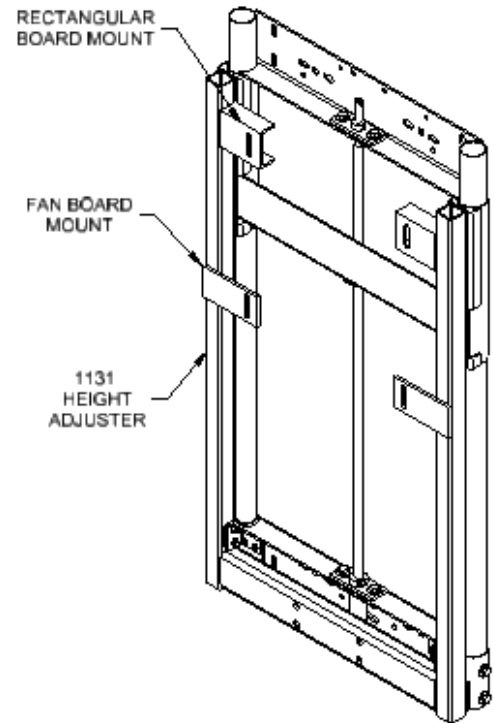

**\*IMPORTANT NOTES are to be in RED BOLD type.**

**\*REGULAR NOTES are to be in Blue type.**

During installation, inspections, and required maintenance, it is important to make sure all bolted connections are properly torqued. The chart below shows the proper torque for fasteners used in this product. All fasteners should be torqued to the values indicated in the chart unless a fastener has a specific torque noted in the instructions or the production prints.

RECOMMENDED BOLT TORQUE				
Bolt Size	Wrench Size	In-Lbs	Ft-Lbs	Nm
1/4"	7/16"	66 to 90	5.5 to 7.5	8 to 10
5/16"	1/2"	132 to 180	11 to 15	15 to 20
3/8"	9/16"	234 to 318	19.5 to 26.5	27 to 36
7/16"	11/16"		31 to 42.5	43 to 58
1/2"	3/4"		47 to 65	64 to 88
9/16"	7/8"		68 to 90	93 to 122
5/8"	15/16"		94 to 130	128 to 176
3/4"	1-1/8"		166 to 230	226 to 312
7/8"	1-5/16"		269 to 372	365 to 504
1"	1-1/2"		402 to 566	546 to 767

- 1.) The picture on the front of this manual is not typical of all installed units. Remove the height adjuster from the packaging. The basic 1131 unit is shown below. If model 1171 or 1171-220 have been purchased, install the electric height adjuster on the mast and install board and goal the same as the 1131 manual height adjuster. The motor will have been installed and the limits will have been set at the factory.

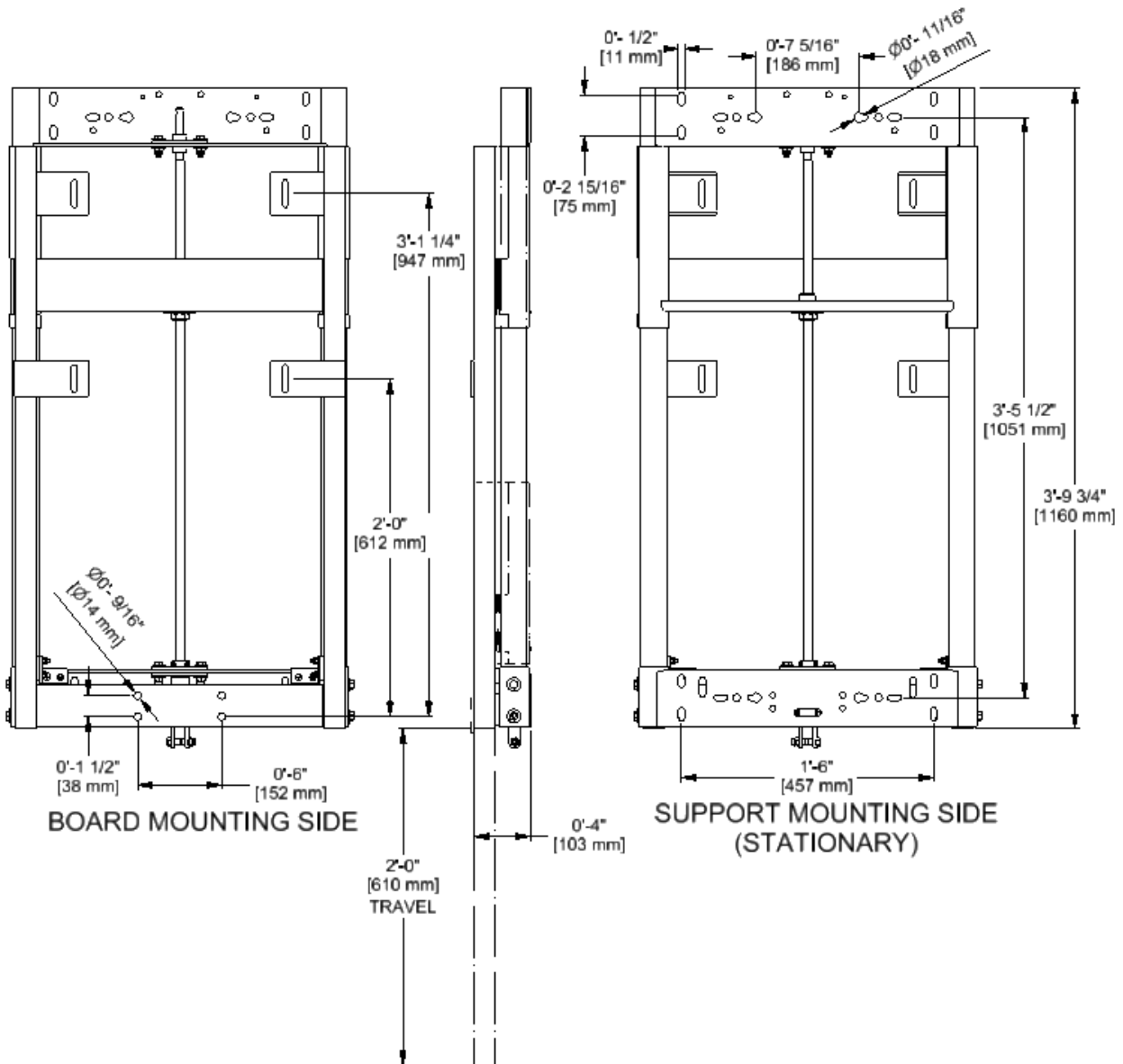

2.) Attach the Direct Mount Extension (DME) to the front of the height adjuster frame with the bolts supplied. Tighten the bolts securely. See below.

PN: 4404 KIT, 63" X 36" RECT BOARD MOUNT

PN: 4405 KIT, 35" X 20" FAN BOARD MOUNT

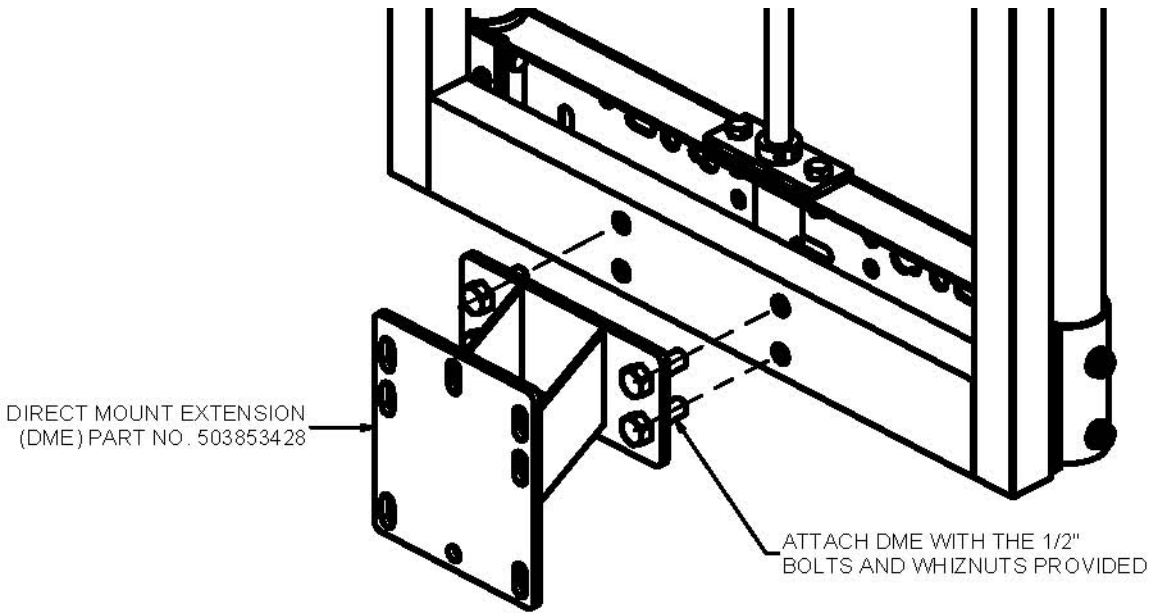

3.) The DME is your starting point for any board you install on this equipment. Attach the bottom of the backboard and the goal to the DME with the bolts provided as shown below. Leave bolts slightly loose until the top of the board is also attached.

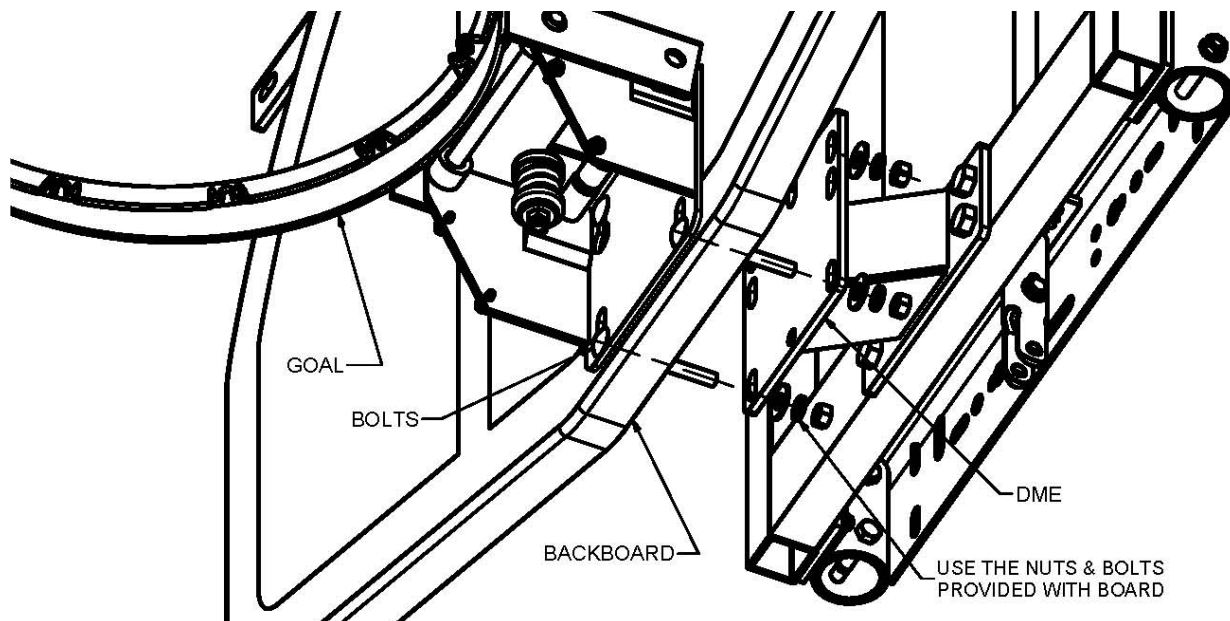

4.) Attachment of the upper section of the narrow or wide boards is dependent upon how the backboard support angle and adjustable feet are attached. First attach the adjustable feet to the rear of the board as shown in the following illustrations. The part number for the adjustable foot is 503852349.

NOTE: Hex bolts are used if the board has threaded inserts, which are supplied within the bank angle hardware kit.

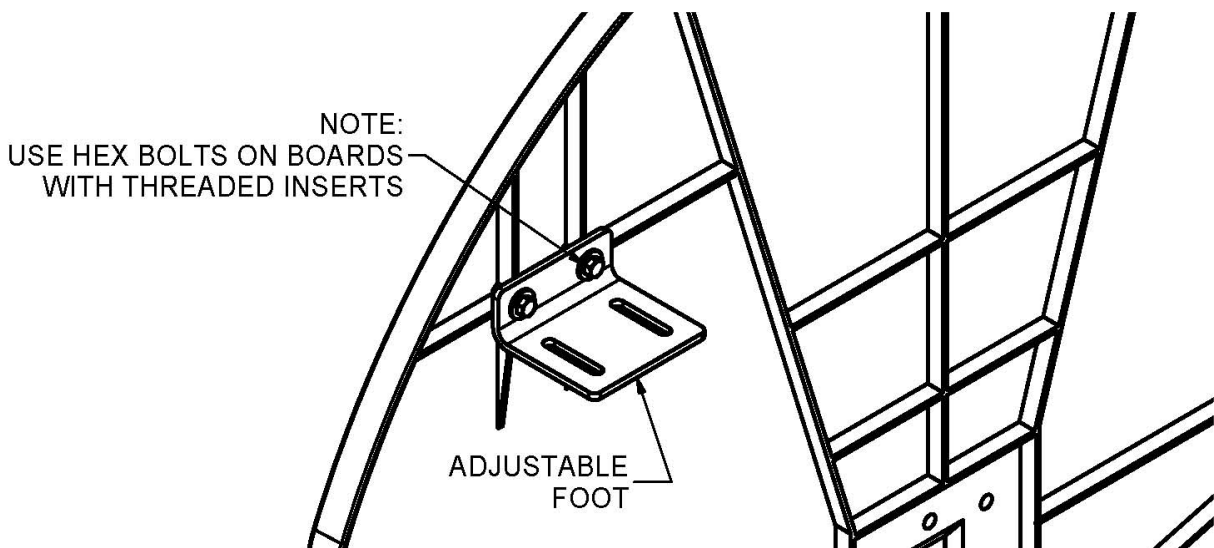
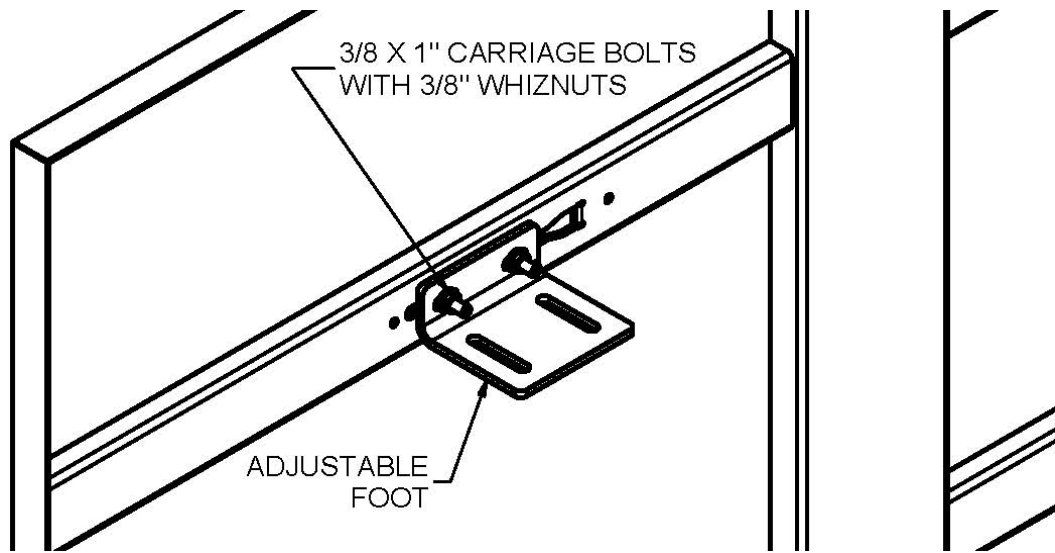

5.) Next attach to the correct backboard support angle for either the narrow or wide mounting application depending on which board you are attaching. The narrow board support angle, part number 504151667, has a 35" wide mounting configuration and is shown below.

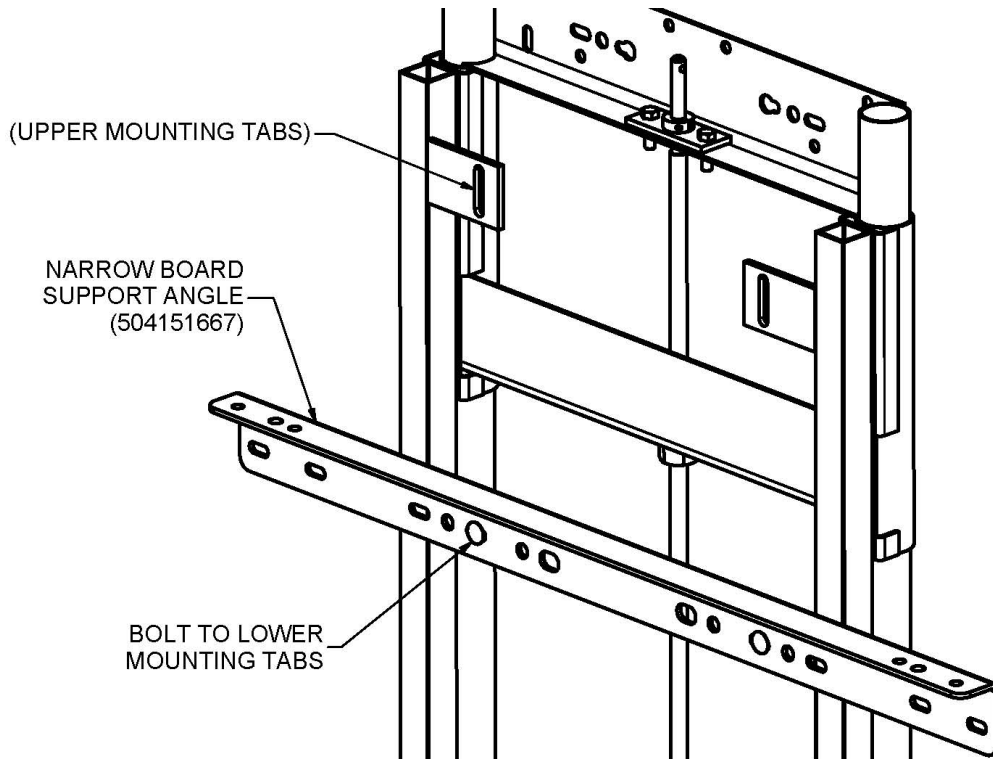

The wide board support angle, part number 504151666, has a 63" wide mounting configuration and is shown below.

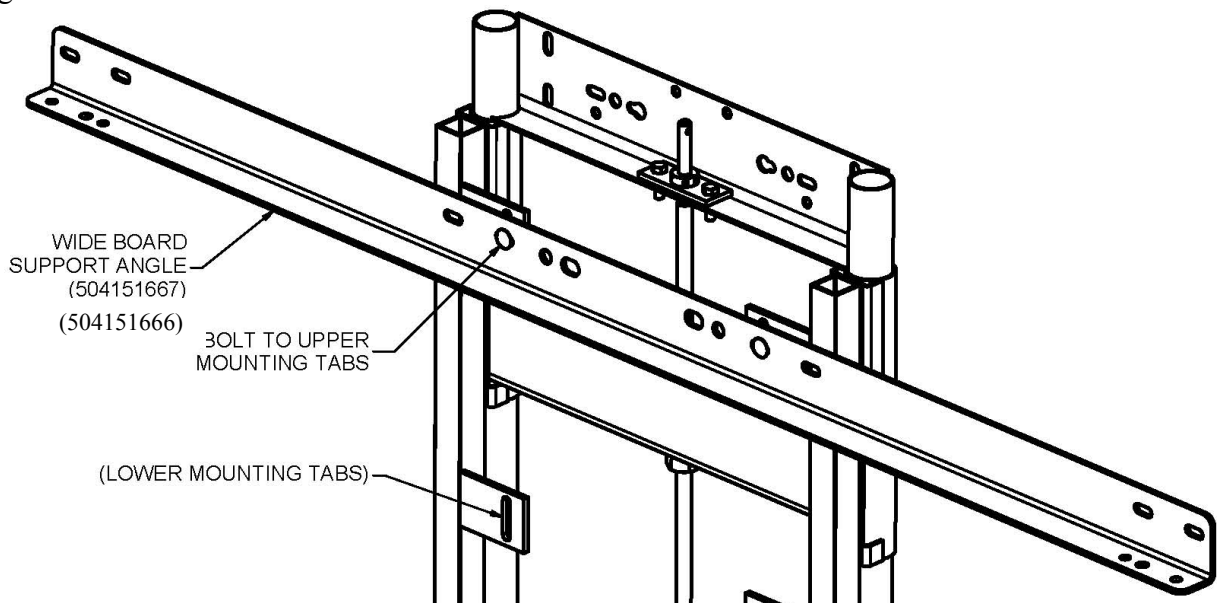



6.) There are several ways to mount the boards to the height adjuster using the backboard angles and the adjustable feet. See figures 1, 2, 3 and 4. Reference board numbers under each illustration.

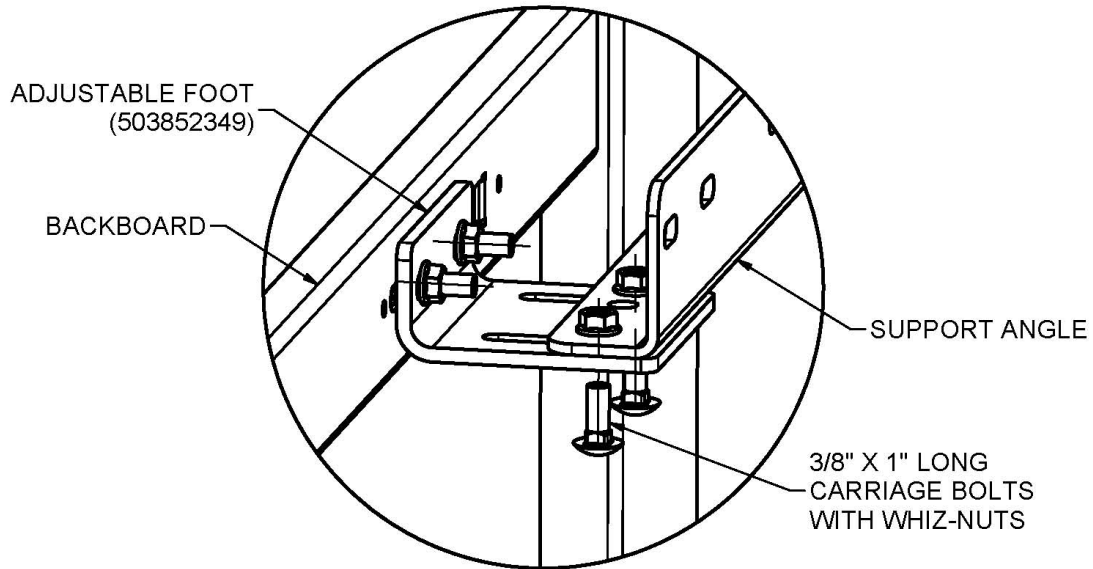

**FIGURE 1:** use for: 1301B, 1270B, 1260B, 1272B, 1401B, 1370B, AFRG48

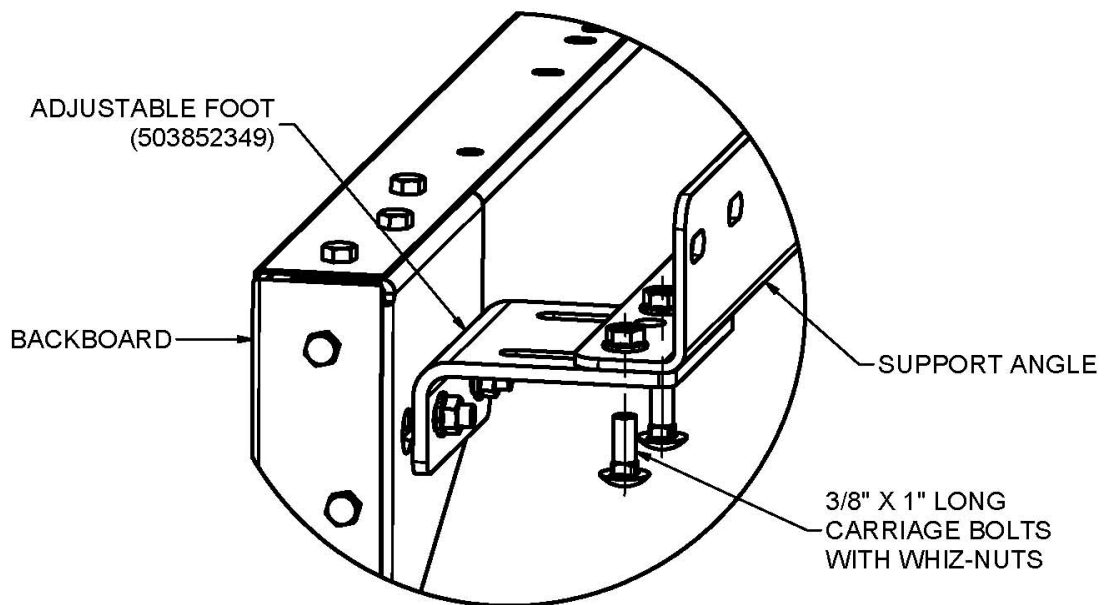

**FIGURE 2:** use for: 1750B, 1442B, AFRG42, LXP4200

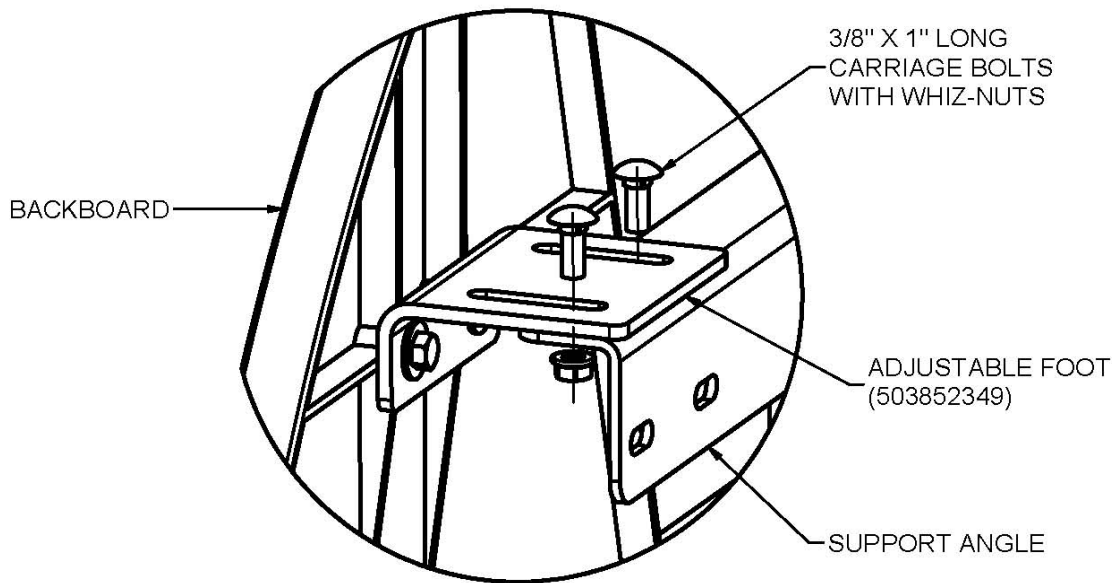

**FIGURE 3:** use for: **1354B**

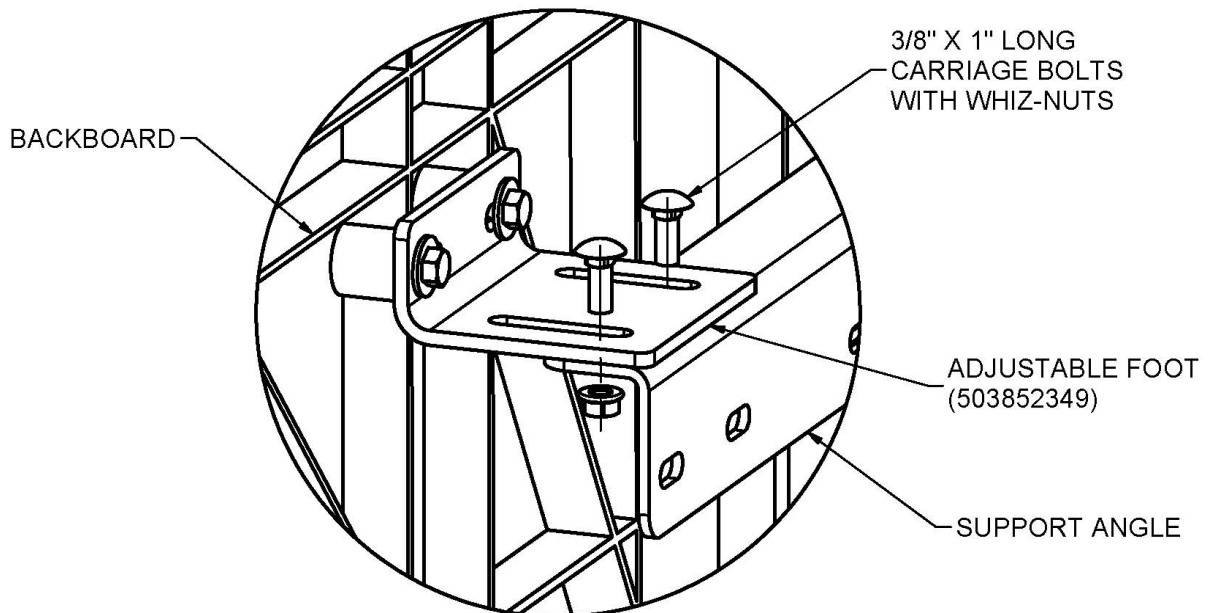

**FIGURE 4:** use for: **1342B**

The above figures are a quick reference of the orientation of the backboard support angles and the adjustable foot angle. In some cases the mounting of the backboard support angle will be on the top mounting tab of the height adjuster and in other cases it will use the bottom mounting tabs. The orientation of the angles and the board mounting will tell you which one to attach to.

7.) Leave all hardware loose until all connections are made for the angles, board and DME. Install the height adjuster to the unit structure. Make sure the post is plum on all ceiling hung units before installation of the height adjuster. Refer to the instructions supplied with the ceiling hung backstop for plumbing the mast. Attach height adjuster with the board and hardware. Tighten down the attachments to the structure and then level and tighten the board and goal. Make sure that the goal height is at 10' when height adjuster is in full up position.

8.) The height decal can be applied at this time to either side of the height adjuster. If the height adjuster has electrical activation, you will want to put the decal on the side of the height adjuster unit which can be seen from the key switch. The illustration below shows where to put the decal. First remove the backing from the arrow decal and place it where indicated. Install the arrow on the rear, stationary frame pointing towards the board. Next remove the backing from the tall height decal and apply it as shown. The height decal must be installed so the 10' mark is now in line with the arrow. This allows the user to view the goal height from a distance. The arrow will point to the current height as it is adjusted.



HEIGHT DECAL  
Align 10 ft  
mark  
with arrow.

ARROW DECAL



## HEIGHT ADJUSTER TO SINGLE POST INSTALLATION

PN: 1408 KIT, AAG TO 6 5/8" MAST

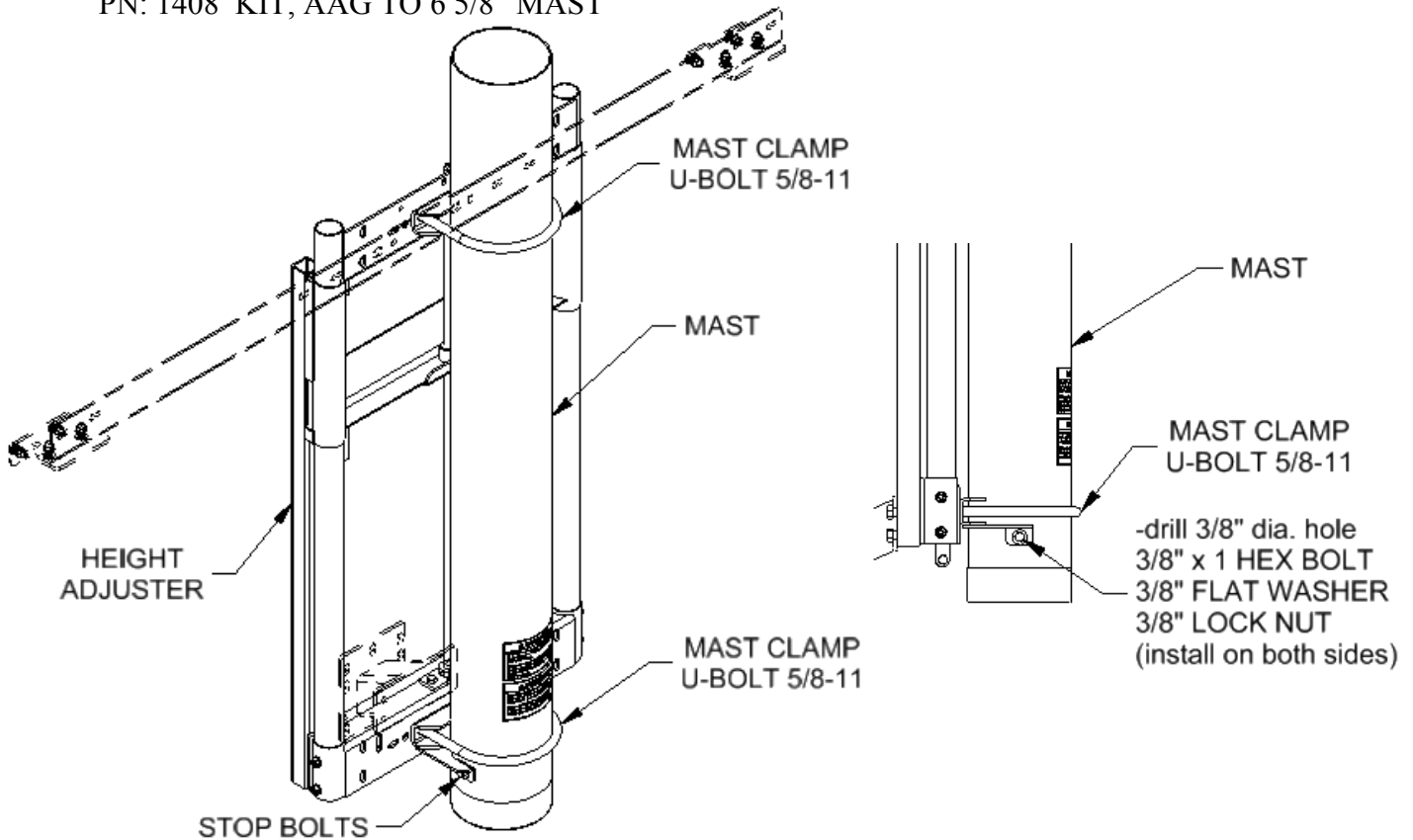

1. After board and goal have been adjusted for plumb, level, and the proper height A.F.F., make sure all 5/8" Mast Clamp U-bolts have been torqued to 94 to 130 ft-lbs.
2. Using a 3/8" diameter bit, drill through the mast tube at the 3/8" hole on each side of the lower mast clamp.
3. Install a 3/8" x 1 hex bolt on each side of mast clamp using a 3/8" flat washer under bolt head and lock nut.

<b>⚠ WARNING</b>
<p>The 5/8" mast clamp U-bolt nuts <b>MUST</b> be torqued to a value of 94 to 130 Ft-Lbs. [128 to 176 Nm].</p> <p>Failure to torque the U-bolt nuts to the specified value could allow the backboard to slip off the mast resulting in serious injury or death.</p> <p style="text-align: right; font-size: small;">123951581</p>

<b>⚠ WARNING</b>
<p>Stop Bolts <b>MUST</b> be installed on each side of the mast clamp after final adjustment. See installation instructions.</p> <p>Failure to install these bolts could allow the backboard to slip off the mast resulting in serious injury or death.</p> <p style="text-align: right; font-size: small;">123951584</p>

## HEIGHT ADJUSTER TO WALL MOUNT INSTALLATION

The following illustration shows how the height adjuster attaches to the wall mount frames. Use the 1/2" nuts and bolts provided to attach the frame two places top and bottom as shown.

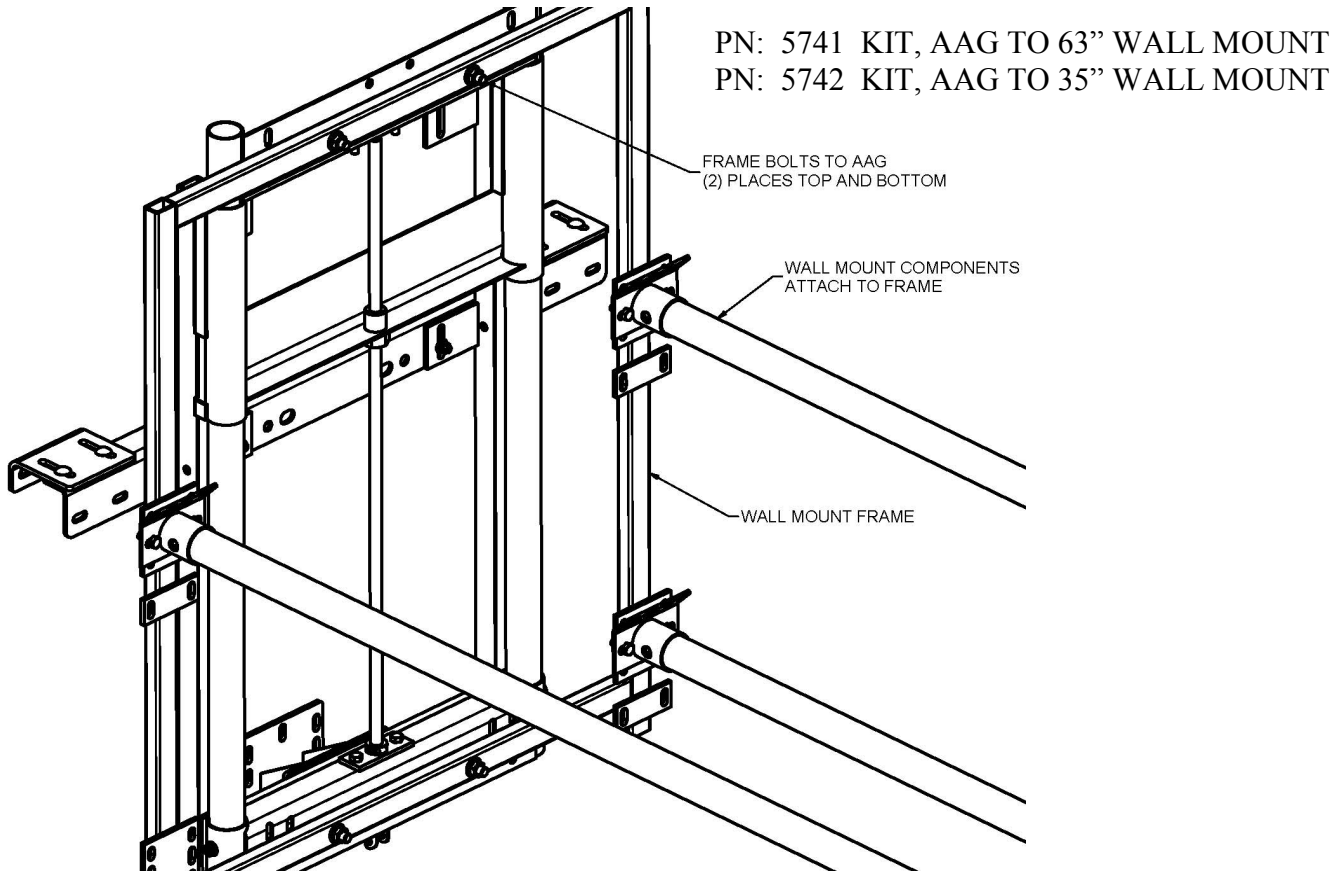

Note: An Adder Bracket, 504155421, needs to be attached to the bottom of the frame to accommodate 48" high backboards. The frame will need to be drilled to accept 3/8" bolts. (frame does not come pre-drilled).

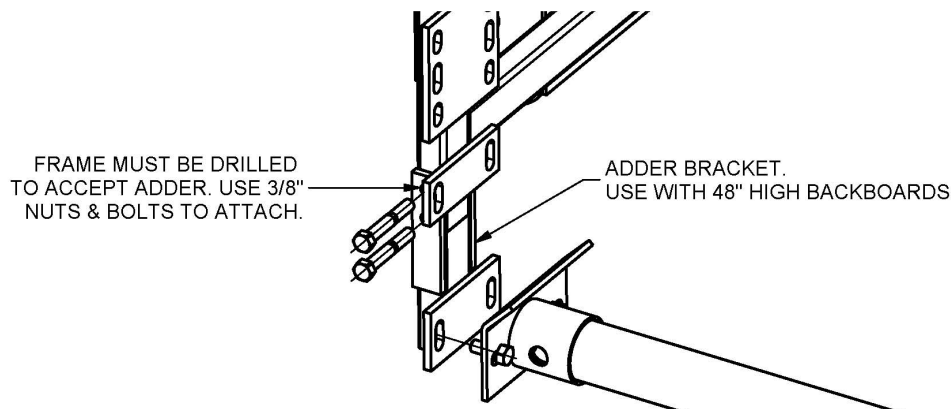

**AAG TO DUAL POST INSTALLATION**

The following illustration shows how the height adjuster mounts to the dual post configuration. Use the small U-bolts two places top and bottom to bolt the height adjuster unit to the horizontal cross pipes as indicated.

PN: 3510 Kit, AAG to 35" x 2 3/8" Dual Post    PN 3511 Kit, AAG to 63" x 2 3/8" Dual Post  
PN: 3512 Kit, AAG to 35" x 3 1/2" Dual Post    PN 3513 Kit, AAG to 63" x 3 1/2" Dual Post

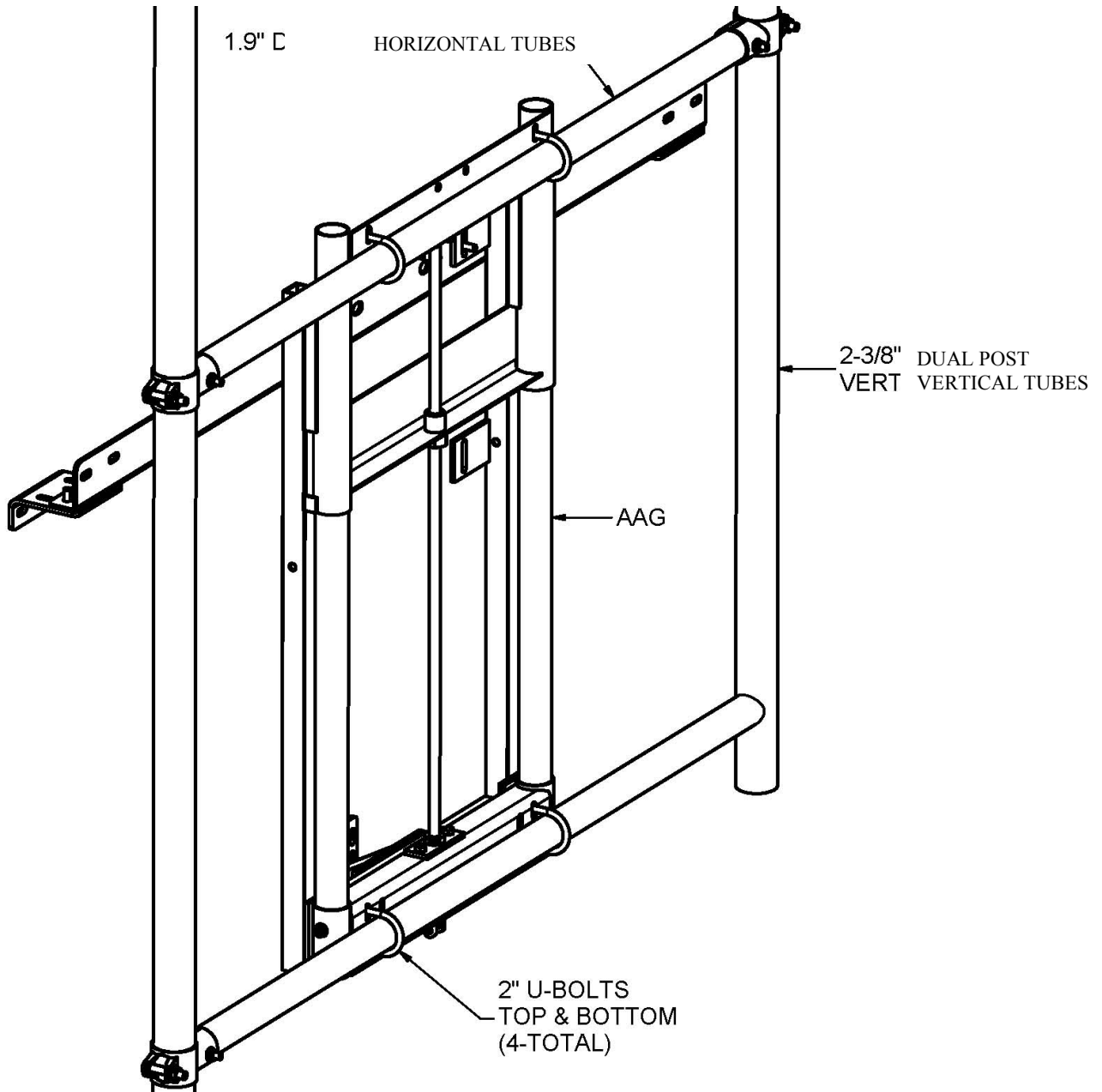

## Electrical Installation (1171 models)

Electrical wiring should be completed by a qualified electrician.

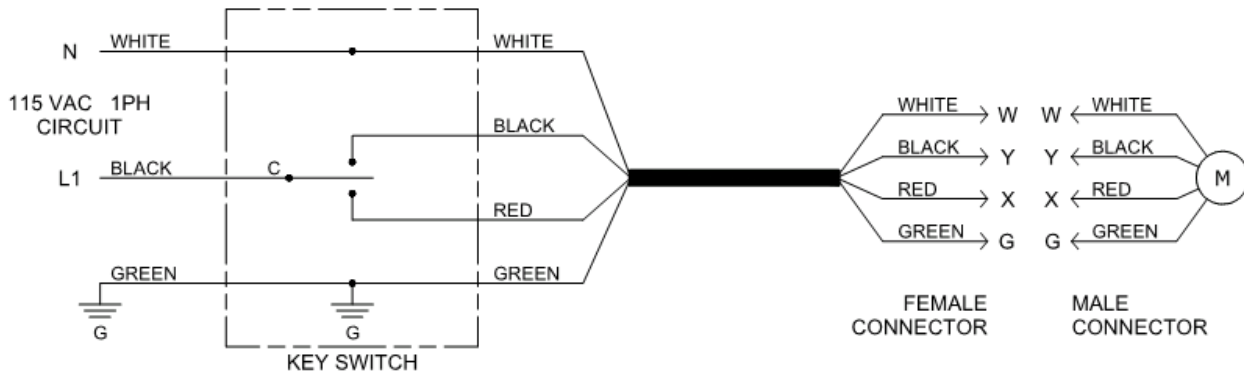

**Wiring Schematic 115v 1ph 60hz**

**MINIMUM CIRCUIT REQUIREMENTS**  
 -DEDICATED 115VAC, 1PH, 60HZ,  
 15 AMP SERVICE

**MOTOR SPECIFICATION**  
 -1/8HP 115VAC, 1PH, 60HZ, 1.3 FLA  
 -INSTANT REVERSING  
 -AUTO RESET THERMAL O/L

**MINIMUM WIRE SIZE**  
 (copper wire, 3% max voltage drop)  
 0-430 ft.....14 ga.  
 430-690 ft.....12 ga.

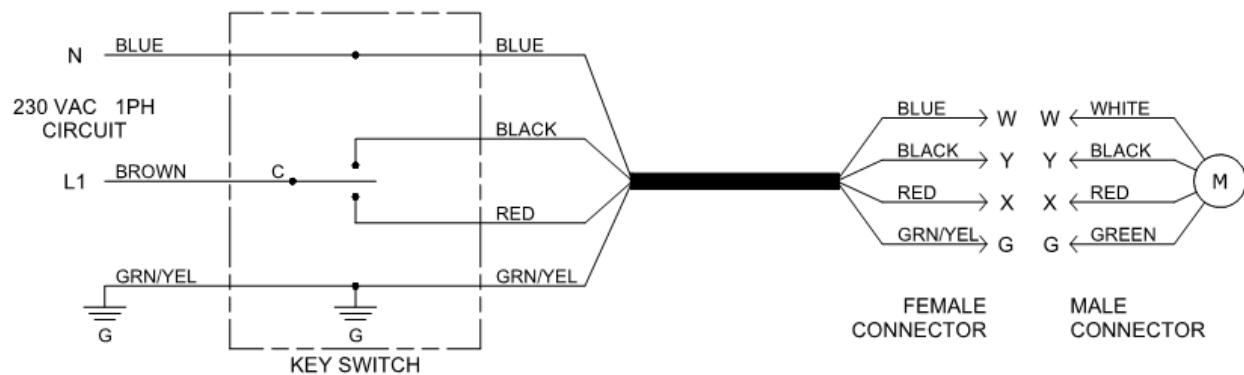

**Wiring Schematic 230v 1ph 50hz**

**MINIMUM CIRCUIT REQUIREMENTS**  
 -DEDICATED 230VAC, 1PH, 50HZ,  
 10 AMP SERVICE

**MOTOR SPECIFICATION**  
 -1/10HP [.75 w] 230VAC, 1PH, 50HZ, 0.7 FLA  
 -INSTANT REVERSING  
 -AUTO RESET THERMAL O/L

**MINIMUM WIRE SIZE**  
 (copper wire, 3% max voltage drop)  
 1500 ft [470 M].....14 ga. [2 mm2]

## OPERATION

### 1131 Manual Height Adjuster

1. Hook the Crank, option 9120-11-08, into Slide Lock casting on bottom of height adjuster. Pull down to unlock and turn crank counter clockwise to lift, clockwise to lower. Stop at any height between 10' and 8' goal height and remove crank.

**Do not crank forcibly past the stops.**

### 1171 Electric Height Adjuster

Key Switch Operation (1158 option)

1. Turn key in appropriate direction (right=up, left=down) and hold key in position until unit is completely raised or lowered based on preset limit switch stops. The motor will automatically stop when the limit switch engages, even if the key is still turned in the up or down position. The height adjuster can be stopped at any desired goal height between 10' and 8'.
2. The electric hoist provided by the manufacturer is equipped with an instant reverse feature. This feature allows the user to instantly reverse the direction of the backstop with a simple change of key position. **HOWEVER**, never purposely or quickly reverse the operation without momentarily stopping in the "neutral" position, as this may cause gear damage, circuit overload or damage to the limit switches.
3. The height adjust can be manually moved using the optional 9120-11-08, Crank. Turn crank counter-clockwise to lift or clockwise to lower. **Do not crank forcibly past the stops.**

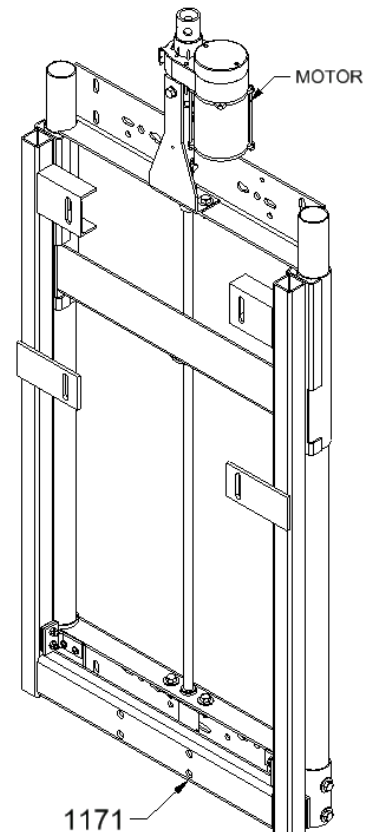
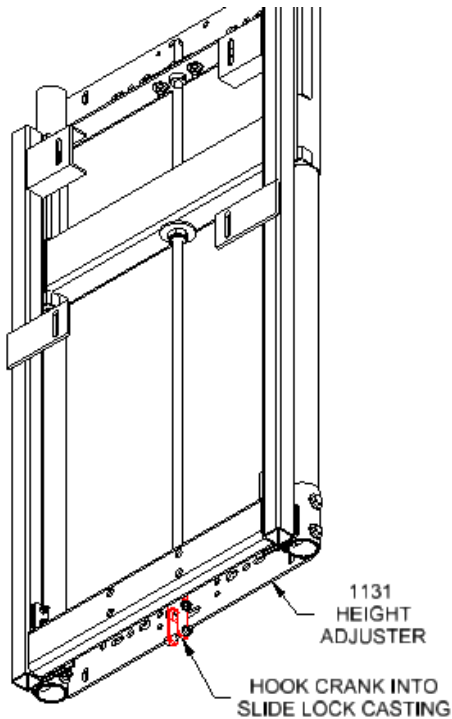



## MAINTENANCE

The following illustration shows the assembly of the manual height adjuster. The maintenance is the same for the electric version as well as the manual.

1. The main slide tubes must be lubricated at all times. For typical installations, it should be lubricated every 6-8 months.
  - a. Lift the unit to the full up position.
  - b. Using a White Lithium aerosol grease, apply a thin even coat of grease to the main slide tubes.
  
2. Check for wear and grease the rod assembly. For typical installations, it should be lubricated every 6-8 months.
  - a. Lift the unit to the full up position.
  - b. Using a White Lithium aerosol grease, apply a thin even coat of grease to the screw rod assembly in the area below the bronze nut.
  - c. It is not necessary to lubricate the nylon thrust bearings at the top or bottom of the screw rod.

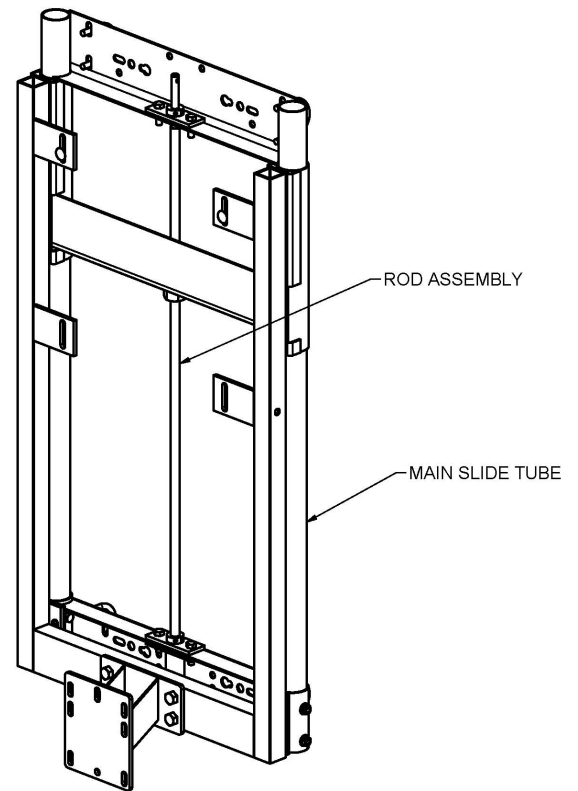

## ACCESSORIES

PN: 9120-11-08	ADJ-A-GOAL CRANK & EXT ROD WHITE
PN: 155351211	AAG ELECTRIC KIT, 115V 1PH 60HZ
PN: 155351440	AAG ELECTRIC KIT, 220V 1PH 50/60HZ
PN: 1158	HDWE KIT AAG LYNRUS KEY SWITCH
PN: 1157	HARDWIRE KIT FOR POWER WAND
PN: 1159	POWER WAND FOR AAG
PN: 1125	PORTABLE CORDLESS ELEC AAG CRANK
PN: 155351411-r001	REBUILD KIT, AAG REV 002,003,004 (shaft and wear pads)
PN: 155351446	REBUILD KIT, SHAFT BEARING, AAG REV 002,003,004



## HEIGHT ADJUSTER



### Gared Holdings, LLC

**Performance Sports Systems**  
9200 E. 146<sup>th</sup> Street  
Noblesville, IN 46060

800-848-8034  
[www.perfsports.com](http://www.perfsports.com)

**Gared Sports**  
9200 E. 146<sup>th</sup> Street  
Noblesville, IN 46060

800-325-2682  
[www.garedsports.com](http://www.garedsports.com)