

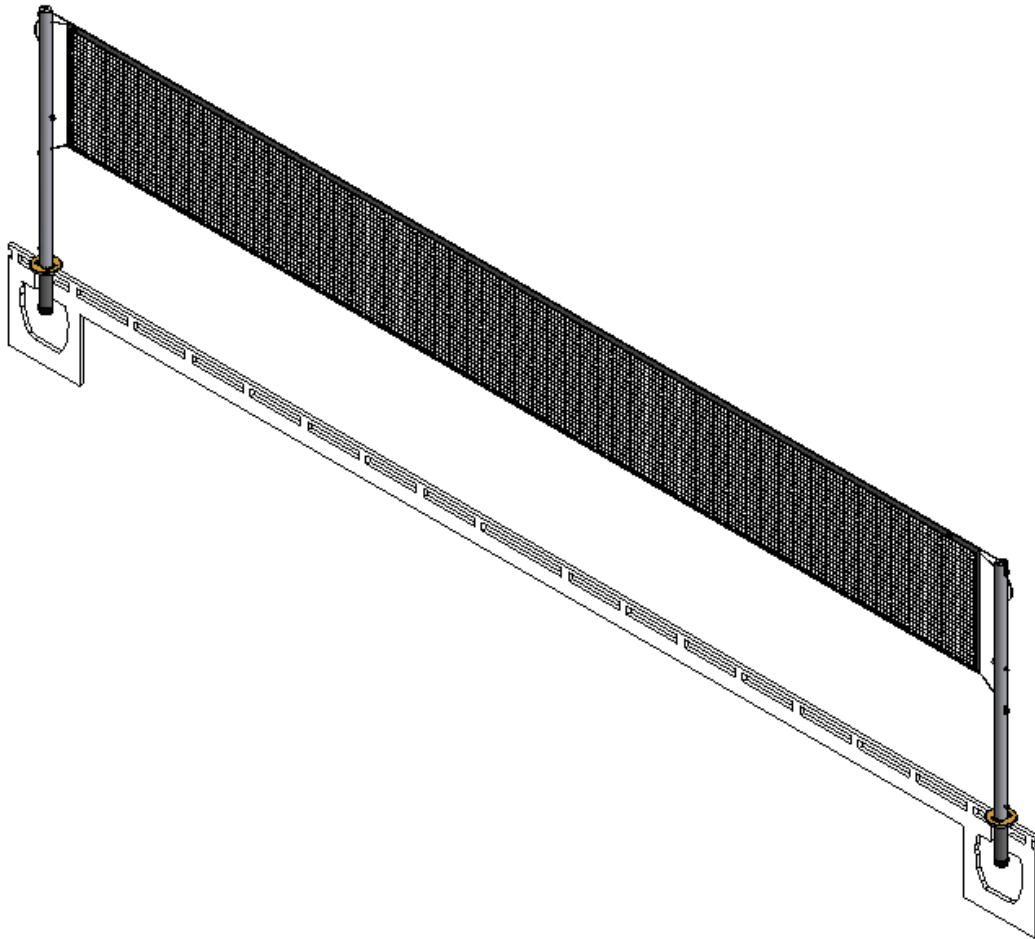

2.38 Rnd Badminton System

Model: 6740



Installation, Operation and Maintenance Instructions

.....
Please read all instructions before attempting installation or operation of these units
.....

SAVE THESE INSTRUCTIONS FOR FUTURE USE



Table of Contents

<u>Section</u>	<u>Page No.</u>
Introduction	1
Specifications	2
Assembly and Setup	3
Unit Operation	5
Maintenance	6

Introduction

Thank you for your purchase of a model 6740. To ensure that our equipment will provide years of use to you, we are including this installation, operation, and maintenance guide. This guide will provide information on the proper assembly and installation methods, operating procedures, and preventative maintenance of your badminton system.

Please do not substitute for factory parts. Contact the Gared or PSS customer service department and allow them to determine if substitute parts are acceptable.

It is recommended that an individual who has been properly trained perform assembly and set up of the badminton. No one under the age of 18 should attempt assembly or set up of the unit, unless properly supervised.

To prevent normal wear and tear from shortening the life of the unit, preventative maintenance inspections and repairs should be performed at least once per year. If the units are subject to high or unusual usage, inspections should be scheduled to occur more frequently. If items are found to be nonconforming, replacements can be ordered from Gared, PSS or one of our authorized dealers. When contacting Gared or PSS, please have information regarding the dealer/installer who sold the unit, the name of the project, and any applicable warranty information.

SPECIFICATIONS

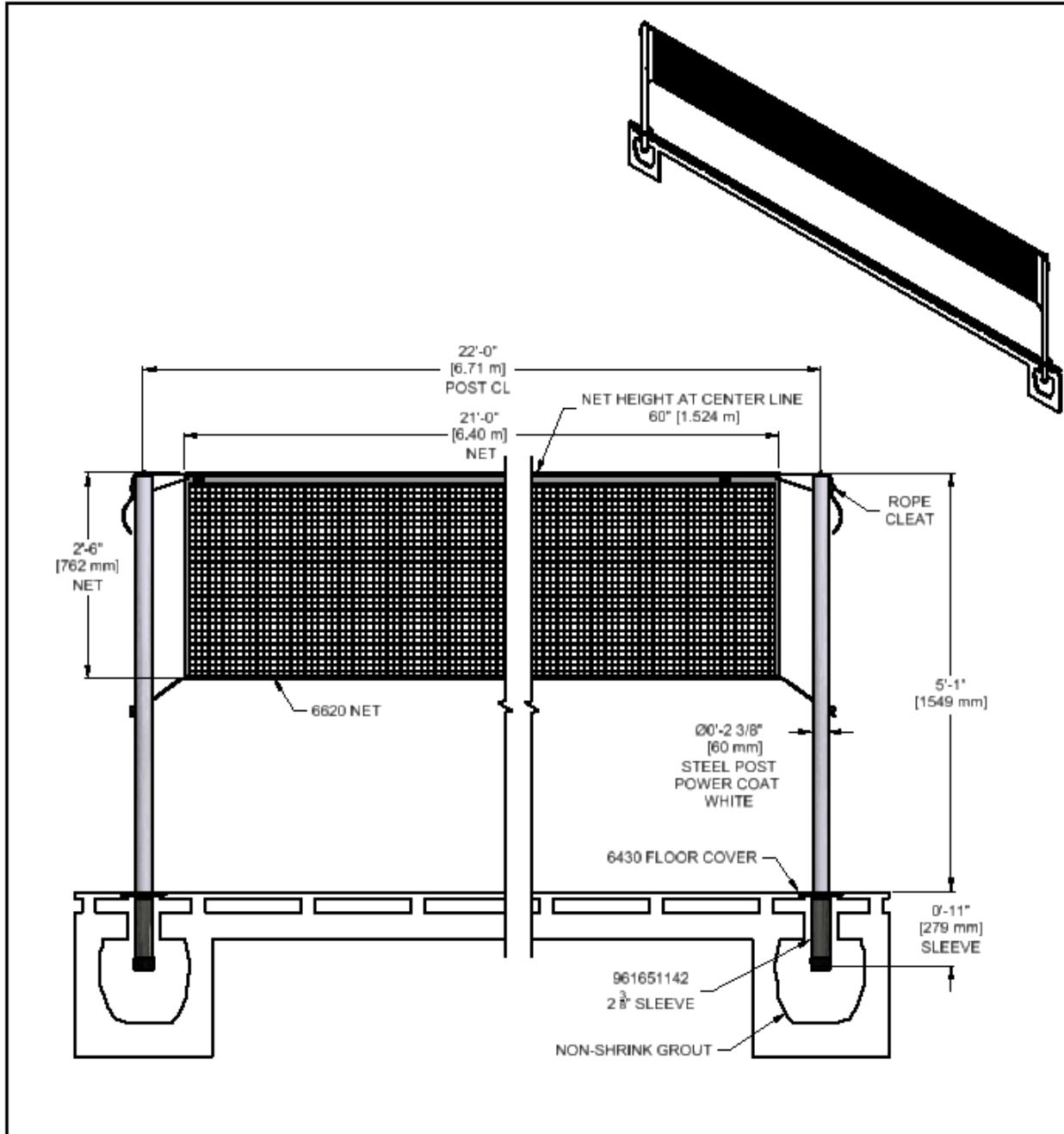

PARTS LIST			
ITEM	QTY	PART NUMBER	DESCRIPTION
1	1	6620	NET, BADMINTON 21' X 2'6"
3	2	961651136	POST ASSY, 2 3/8" RND BAD. PERM
4	2	961651142	2 3/8" FLOOR SLEEVE ASSEMBLY
5	2	6430	6" BRASS FLOOR COVER - LOW PROFILE



6740 Badminton System



INSTALLATION

Installation of the sleeves of the unit is the setting stones of the system. If this process is not correct the remainder of the install will be inaccurate.

1. Mark (2) spots on the floor exactly 22 feet apart (refer to most recent set of architectural prints for exact locations within the gym). These represent the CENTERS of each sleeve installation. If sleeves are to be more or less than 22 feet apart, contact a Gared representative for information regarding this alteration.
2. Cut (2) round holes through the playing surface 4-3/4" to 5", diameter centered on the spots marked in step one.
3. After cutting out the circle in the surface flooring, cut a similar hole in the concrete slab below. The diameter of this hole should be larger than 3-1/2", however the exact size is not critical.
4. When drilling the hole in concrete, the slab must be fully penetrated. Under the slab, hollow out (by hand) an area about 16-20 inches from the playing surface. The hole should be about 6 to 8 inches deeper than the bottom of the sleeve once it is inserted.
5. It is recommended that a "non-shrink" grout be used to anchor the sleeve. Pour the grout mixture into the hole until it is just below the BOTTOM of the concrete hole. Using the cap provided, cover the sleeve during installation to prevent grout from entering the bottom of sleeve.
6. Insert the 2 5/8" O.D. sleeve and work it down into the grout until the inside bottom of the sleeve is 11" below the TOP surface of the floor. Incorrect sleeve depth will result in a net height error.
7. Turn the ring and cover plate upside down and approximately center it over the hole. Holding it firmly in place, outline it on the floor. Note: The purpose in centering this ring and cover above the sleeve is to allow the post to pass through the sleeve below. It may be slightly off-center and still work. This oversized design facilitates any movement of the floor now or in the future.
8. Using a router and template, route a counter bore 6-7/16" diameter to a depth of about 17/32" to receive the floor cover. A template can be made from a piece of Masonite or thick plastic. Make a hole in the template material so that when the router is used with it, (allowance is made for router base plate) the counter bored diameter is 6-7/16". Use a scrap board for practice and to check the outcome of the counter bore first.

Note: Dimensions of the counter bore diameter and depth are based on a using a 6030/6031 floor cover. Be sure they are correct for the cover being installed.

9. Center the template over the 5" diameter hole. When marking the counter bored hole, keep pressure on the template at all times to prevent slippage.
10. To prevent slipping of the template during the routing, tape the template to the floor or apply continuous pressure to the template. Do not cut full depth of the

counter bore in one pass. Gradually work down to the depth until the floor plate is flush with surface floor. Place the floor plate down into the counter bore several times so as to not make the hole too deep. When installed, the plate must be perfectly flush with the top surface of the floor.

11. Place the ring in the routed out portion of the hole. Inside the ring are (4) holes. Use wood screws provided in the holes to secure the ring to the floor. Pre-drill pilot holes in wood to prevent wood screws from splitting the wood floor. Normally locate covers in such a fashion that they open away from the court, though this is not critical.
12. Wait a minimum of (7) days to allow the grout to completely cure before setting up the posts.

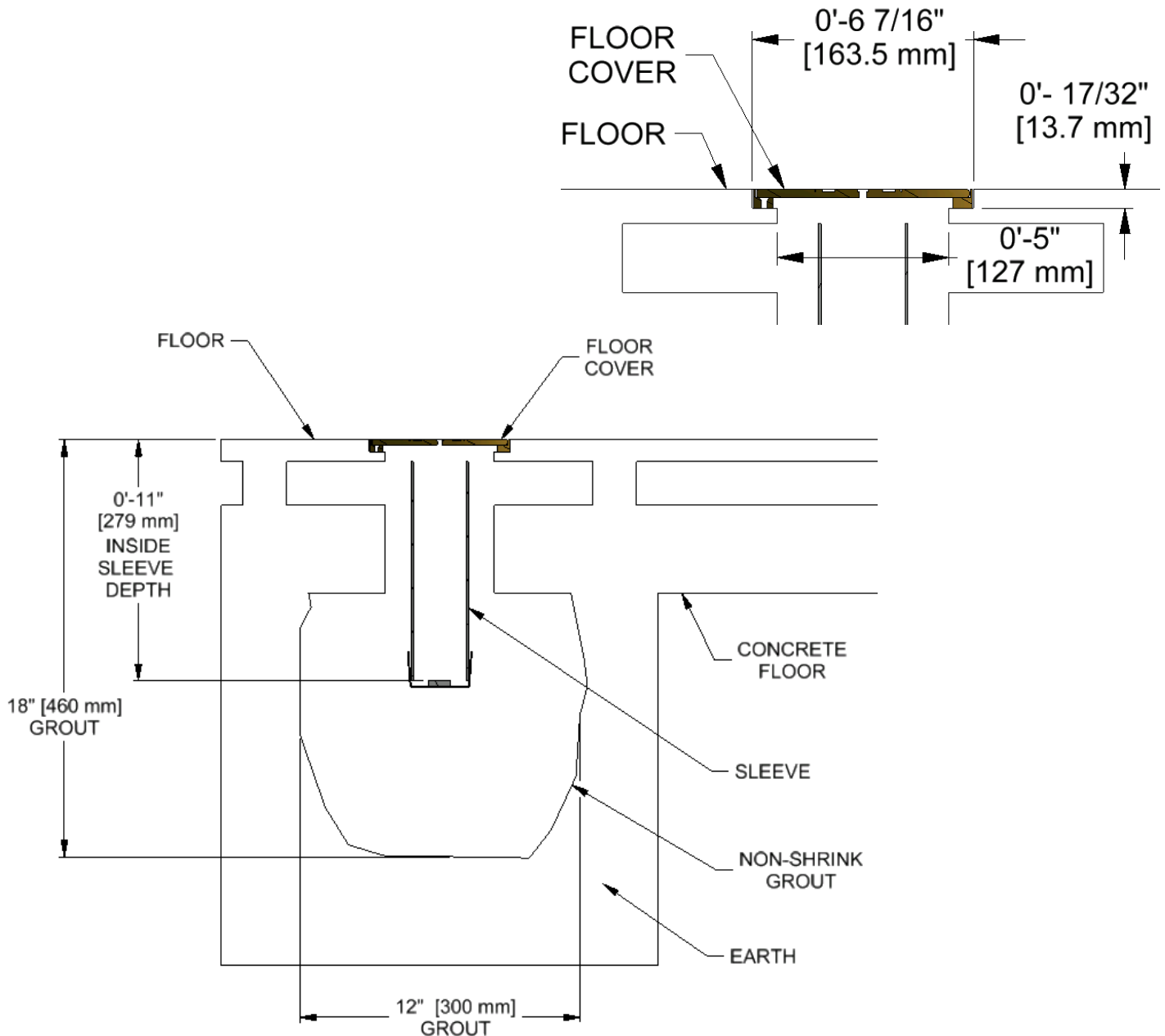

OPERATION

1. Now that the sleeves and covers are install and the grouting has cured, the system can be setup for playing badminton.
 - a. Open the floor covers and place each post into the sleeves with the rope clasp positioned away from the court side.
 - b. The net rope goes through the rope guide and down to the rope clasp to keep it tensioned. Tension net to a 60" playing height at the center of the court and press into the rope clasp. The top and bottom rope attachment goes through the net grommets and ties to the post as shown.

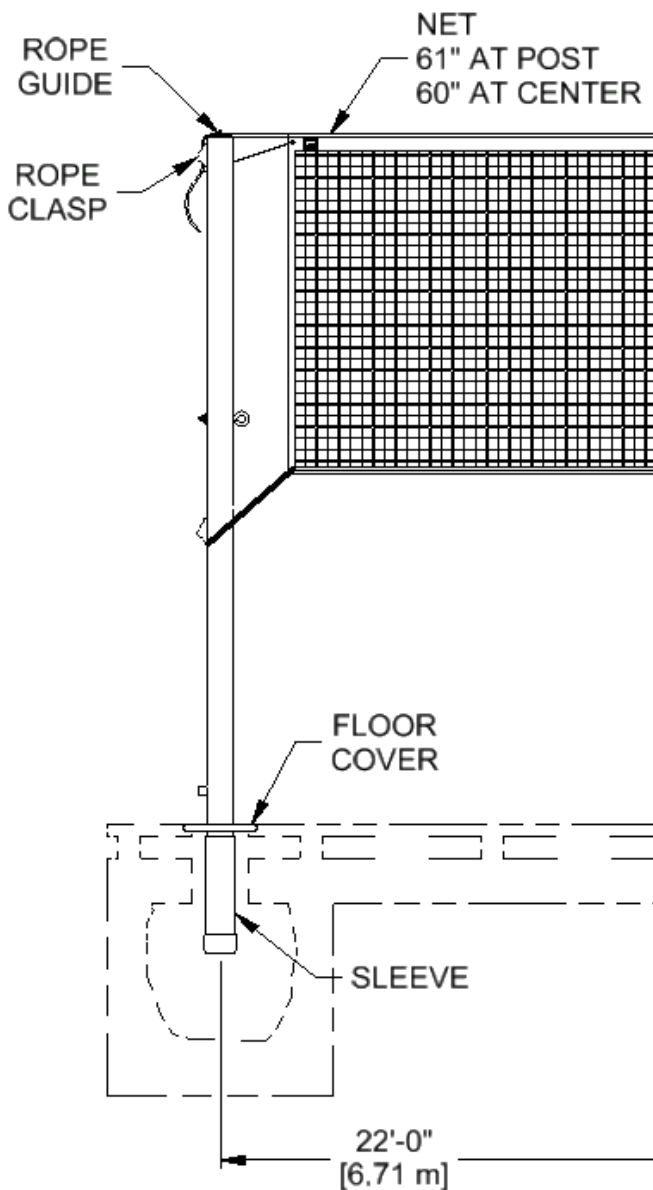



6740 Badminton System



2. To take the system down;
 - a. Untie top and bottom net straps
 - b. Release net tension by pulling rope out of rope clasp and removed net. Fold net up for storage.
 - c. Remove net posts and move to storage.
 - d. Be sure to close floor covers. Covers must fit flush with floor for safe play.

Maintenance

Annually check over the badminton system and make sure no parts are damaged. If damaged the manufacturer or dealer should be contacted for replacement parts.



Gared Holdings, LLC

**Performance Sports Systems
9200 E. 146th Street
Noblesville, IN 46060**

**800-848-8034
www.perfsports.com**



**Gared Sports
9200 E. 146th Street
Noblesville, IN 46060**

**800-325-2682
www.garedsports.com**