



(2) KEY SWITCHES AND COVERS INCLUDED
2x4x 2 1/2 BOX NOT INCLUDED

ELECTRICAL DATA

-2HP GEAR-MOTOR, 3PH 60HZ W/BRAKE & (1/4 HP TROLLEY MOTOR)

- 208 VAC, 6.1 A + (1.3 A)
- 230 VAC, 5.9 A + (1.0 A)
- 460 VAC, 3.5 A + (0.5 A)

-INCLUDES A KEY SWITCH AND 2x4 BOX COVER. A 2x4x2¹/₂"d JUNCTION BOX SUPPLIED BY OTHERS.

-FUSED DISCONNECT SUPPLIED BY OTHERS. ALL WIRING AND RECEPTILES SUPPLIED BY OTHER.

-CORRECT MOTOR ROTATION MUST BE VERIFIED BY ELECTRICAL CONTRACTOR DURING ELECTRICAL INSTALLATION. REVIEW INSTALLATION MANUAL FOR IMPORTANT INSTRUCTIONS.

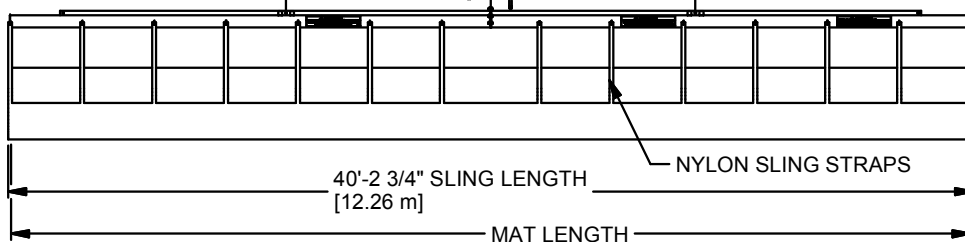
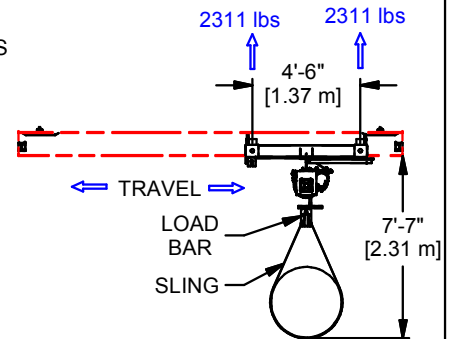
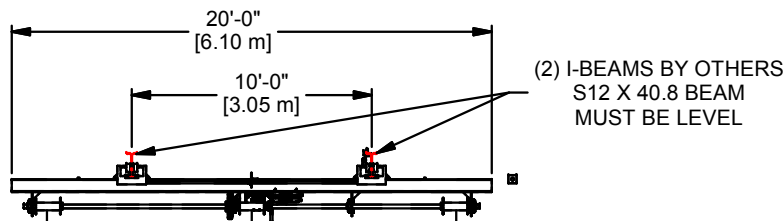
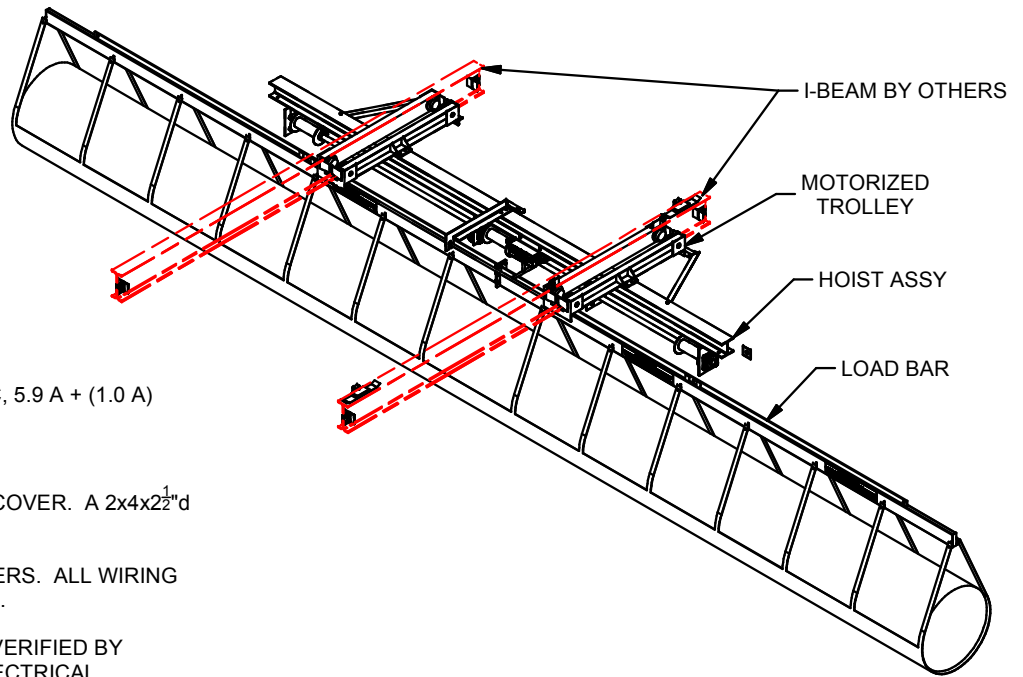

	WEIGHT (lbs)
MAT HOIST ASSY, W/TROLLEY	1,800
LOAD BAR & SLING	616
ROLLED MAT (maximum)*	2,205
TOTAL	4,621

*TOTAL MAT LENGTH NOT TO EXCEED 45'

NOTES:

- STRUCTURE SUPPLIED BY OTHERS TO BE FIELD VERIFIED BEFORE PRODUCTION.
- KEY SWITCH MUST BE LOCATED IN AN AREA THAT ALLOWS THE HOIST TO BE VISIBLE TO THE OPERATOR, BUT CLEAR OF THE MAT LOAD.

B	WDC	11-10-16
REV	BY	DATE



Gared Holdings, LLC
9200 E. 146th St. Noblesville, IN 46060

THIS DOCUMENT CONTAINS TRADE SECRET AND OTHER MATERIALS WHICH ARE PROTECTED BY CONFIDENTIALITY NOTICE AND AGREEMENT AND BY COPYRIGHT. ANY USE OR COPYING OF THIS DOCUMENT EXCEPT AS AUTHORIZED BY GARED HOLDINGS, LLC IS STRICTLY PROHIBITED.

MAT HOIST, 40' SGL LOAD BAR, SIDE MOVING

DRAWN	CROSBY	DATE	11/10/2016	DATE ISSUED
APPROVED		DATE		
FILE LOC. Q:\Inventor Files\Specification Files\10_Curtains				
SIZE	SCALE	SHT. NO.	PART NO.	REV
A		1 OF 2	4098	B



MODEL 4098
SIDE MOVING WRESTLING MAT STORAGE SYSTEM
WITH 40' LOAD BAR FOR SINGLE SLING

RECOMMENDED APPLICATION

This unit allows user to gain storage space and reduce risk of injuries to students and coaches. Simply roll the mat into the vinyl sling, attach it to the load bar and turn the key. The mats are easily raised and stored at ceiling height. The 4098 wrestling mat storage system lifts one mat roll up to 45 ft long and can be easily mounted in most gyms. Once the mats are raised the motorized trolley system moves the mats away from the main room.

SPECIFICATIONS

OVERHEAD SUPERSTRUCTURE

The model 4098 Wrestling Mat Storage System is supported from the roof structure. Two S12 x 40.8 I-beams, serving as the trolley track, are supplied and installed by general contractor. The supplied beam must be level and evenly spaced.

DRIVE / SUPPORT STRUCTURE

Drive and spools are attached to a W6 x 25 I-beam frame weldment for rigid support. A one piece 2" solid keyed drive shaft runs on four self-aligning machined ball bearing pillow blocks. Unit includes three 4" diameter cable drums to prolong cable life. Lifting rate shall be 13.6 fpm. Finish shall be black power coat. Unit is shipped upright on metal stands for safer installation.

The model 4098 Wrestling Mat Storage System shall be operated by a 2 horsepower, 3ph reversible motor available for connection to 208, 230, or 460 VAC power. Unit includes a 48 to 1 industrial in-line helical gear speed reducer and a 20-ft./lbs. electric brake. The trolley is driven by a ¼ horsepower gear motor.

Motor controls include motor reversing contactors and motor overload protection. Fused disconnect is to be provided by others. An audible alarm shall sound when unit is operating. Two key switches and 2x4" switch covers are included. Key switches must be located in an area that allow the hoist to be visible to the operator, but clear of the mat load. Limit switches shall control the up and the down travel and moving travel. A second up limit switch shall be included for extra safety. The trolley motor is interlocked so that it can travel only in the up position. Controls are shipped attached to the hoist frame and are factory wired and tested.

A 40' long, welded 2" x 6" rectangular load bar is raised by three 5/16" galvanized carbon steel aircraft grade cables. Cables shall have an ultimate load rating of 9800 lbs each. Load bar shall be equipped with steel hooks to accommodate "D" rings on sling straps.

SLING

Mat sling shall be constructed of 18-ounce vinyl with twelve 2" wide nylon straps that wrap all the way around the sling. Nylon straps to have 7000# breaking strength and "D" rings and self-closing hooks at end of strap.

OPTIONS

155655941 MAT HOIST SAFETY STRAP PACKAGE (includes (2) 1109 Mat Locks)
801703914 RELAY BOX ASSY (for use with TSC2000 series control system)